

STANDBY POWER RATING

150 kW, 188 kVA, 60 Hz

PRIME POWER RATING*

135 kW, 169 kVA, 60 Hz

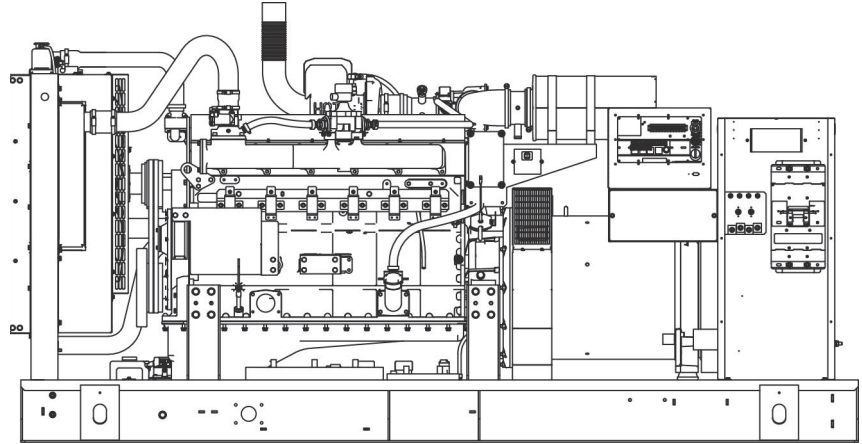

*Built in the USA using domestic and foreign parts

*EPA Certified Prime ratings are not available in the U.S. or its Territories.

Image used for illustration purposes only

CODES AND STANDARDS

Generac products are designed to the following standards:

 UL2200, UL508, UL142, UL498

 NFPA70, 99, 110, 37

 NEC700, 701, 702, 708

 ISO9001, 8528, 3046, 7637, Pluses #2b, 4

 NEMA ICS10, MG1, 250, ICS6, AB1

 **ANSI**
 American National Standards Institute
 ANSI C62.41

 **ICC** **osHPD**
 IBC 2009, CBC 2010, IBC 2012, ASCE 7-05,
 ASCE 7-10, ICC-ES AC-156 (2012)

POWERING AHEAD

For over 50 years, Generac has led the industry with innovative design and superior manufacturing.

Generac ensures superior quality by designing and manufacturing most of its generator components, including alternators, enclosures and base tanks, control systems and communications software.

Generac's gensets utilize a wide variety of options, configurations and arrangements, allowing us to meet the standby power needs of practically every application.

Generac searched globally to ensure the most reliable engines power our generators. We choose only engines that have already been proven in heavy-duty industrial application under adverse conditions.

Generac is committed to ensuring our customers' service support continues after their generator purchase.

STANDARD FEATURES

ENGINE SYSTEM

General

- Oil Drain Extension
- Air Cleaner
- Fan Guard
- Stainless Steel flexible exhaust connection
- Critical Exhaust Silencer
- Factory Filled Oil & Coolant
- Radiator Duct Adapter (open set only)

Fuel System

- Primary and secondary fuel Shutoff

Cooling System

- Closed Coolant Recovery System
- UV/Ozone resistant hoses
- Factory-Installed Radiator
- 50/50 Ethylene glycol antifreeze
- Radiator drain extension

Engine Electrical System

- Battery charging alternator
- Battery cables
- Battery tray
- Solenoid activated starter motor
- Rubber-booted engine electrical connections

ALTERNATOR SYSTEM

- UL2200 GENprotect™
- Class H insulation material
- 2/3 Pitch
- Skewed Stator
- Permanent Magnet Excitation
- Sealed Bearings
- Amortisseur winding
- Full load capacity alternator

GENERATOR SET

- Internal Genset Vibration Isolation
- Separation of circuits—high/low voltage
- Separation of circuits—multiple breakers
- Wrapped Exhaust Piping (enclosed Units only)
- Standard Factory Testing
- 2 Year Limited Warranty (Standby rated Units)
- 1 Year Limited Warranty (Prime rated units)
- Silencer mounted in the discharge hood (enclosed only)

ENCLOSURE (IF SELECTED)

- Rust-proof fasteners with nylon washers to protect finish
- High performance sound-absorbing material
- Gasketed doors
- Stamped air-intake louvers
- Air discharge hoods for radiator-upward pointing
- Stainless steel lift on door hinges
- Stainless steel lockable handles
- Rhino Coat™ - Textured polyester powder coat

CONTROL SYSTEM

Control Panel

- Digital G-200 Paralleling Control Panel - Touch-Screen
- Programmable Crank Limiter
- 7-Day Programmable Exerciser
- Special Applications Programmable PLC
- RS-232/485
- All-Phase Sensing DVR
- Full System Status
- Low Fuel Pressure Indication
- 2-Wire Start Compatible
- Power Output (kW)
- kW Hours, Total
- Real/Reactive/Apparent Power
- All Phase AC Voltage
- All Phase Currents
- Oil Pressure
- Coolant Temperature
- Coolant Level
- Engine Speed
- Battery Voltage

- Frequency
- Date/Time Fault History (Event Log)
- Isochronous Governor Control
- Waterproof/sealed Connectors
- Audible Alarms and Shutdowns
- Not in Auto (Flashing Light)
- Auto/O/Manual Switch
- E-Stop (Red Mushroom-Type)
- Customizable Alarms, Warnings, and Events
- Modbus protocol
- Predictive Maintenance algorithm
- Sealed Boards
- Password parameter adjustment protection
- Single point ground
- 15 channel data logging
- 0.2 msec high speed data logging
- Alarm information automatically comes up on the display

Alarms

- Oil Pressure (Pre-programmable Low Pressure Shutdown)
- Coolant Temperature (Pre-programmed High Temp Shutdown)
- Coolant Level (Pre-programmed Low Level Shutdown)
- Low Fuel Pressure Alarm
- Engine Speed (Pre-programmed Over speed Shutdown)
- Battery Voltage Warning
- Alarms & warnings time and date stamped
- Alarms & warnings for transient and steady state conditions
- Snap shots of key operation parameters during alarms & warnings
- Alarms and warnings spelled out (no alarm codes)

PARALLELING CONTROLS

- Auto-synchronization process
- Isochronous load sharing
- Reverse power protection
- Maximum power protection
- Electrically operated, mechanically held paralleling switch
- Sync check system
- Independent on-board paralleling
- Optional programmable logic full auto back-up control (pls)
- Shunt Trip and Auxiliary contact

MG150 | 14.2L | 150 kW

INDUSTRIAL SPARK-IGNITED GENERATOR SET

EPA Certified Stationary Emergency

CONFIGURABLE OPTIONS

ENGINE SYSTEM

General

- Flexible Fuel Line - NPT connection
- Oil Heater
- Air Filter Restriction Indicator
- Stone Guard (Open Set Only)

Fuel Electrical System

- 10A UL battery charger
- Battery Warmer

ALTERNATOR SYSTEM

- Alternator Upsizing
- Anti-Condensation Heater
- Tropical Coating

CIRCUIT BREAKER OPTIONS

- Main Line Circuit Breaker
- Electronic Trip Breaker

GENERATOR SET

- Gen-Link Communications Software (English Only)
- Extended Factory Testing
- 8 Position Load Center
- 2 Year Extended Warranty
- 5 Year Warranty
- 5 Year Extended Warranty

ENCLOSURE

- Standard Enclosure
- Level 1 Sound Attenuation
- Level 2 Sound Attenuation
- Steel Enclosure
- Aluminum Enclosure
- 12 VDC Enclosure Lighting Kit
- 120 VAC Enclosure Lighting Kit
- AC/DC Enclosure Lighting Kit

CONTROL SYSTEM

- 21-Light Remote Annunciator
- Remote Relay Board (8 or 16)
- Oil Temperature Sender with Indication Alarm
- Remote E-Stop (Break Glass-Type, Surface Mount)
- Remote E-Stop (Red Mushroom-Type, Surface Mount)
- Remote E-Stop (Red Mushroom-Type, Flush Mount)
- Remote Communication - Ethernet
- 10A Run Relay,
- Ground Fault Indication and Protection
- Functions

ENGINEERED OPTIONS

ENGINE SYSTEM

- Fluid containment Pans
- Coolant heater ball valves

CONTROL SYSTEM

- Battery Disconnect Switch

GENERATOR SET

- Special Testing
- Battery Box

ENCLOSURE

- Motorized Dampers
- Enclosure Ambient Heaters
- Door Alarm Switch
- 150 MPH Wind Kit

RATING DEFINITIONS

Standby - Applicable for a varying emergency load for the duration of a utility power outage with no overload capability.

Prime - Applicable for supplying power to a varying load in lieu of utility for an unlimited amount of running time. A 10% overload capacity is available for 1 out of every 12 hours. The Prime Power option is only available on International applications. Power ratings in accordance with ISO 8528-1, Second Edition

MG150 | 14.2L | 150 kW

INDUSTRIAL SPARK-IGNITED GENERATOR SET

EPA Certified Stationary Emergency

APPLICATION AND ENGINEERING DATA

ENGINE SPECIFICATIONS

General

| | |
|--------------------------|------------------------------|
| Make | Generac |
| Cylinder # | 6 |
| Type | In-line |
| Displacement - L (cu In) | 14.17 (864.71) |
| Bore - mm (in) | 135 (5.31) |
| Stroke - mm (in) | 165 (6.50) |
| Compression Ratio | 9.5:1 |
| Intake Air Method | Turbocharged/Aftercooled |
| Number of Main Bearings | 7 |
| Connecting Rods | Carbon Steel |
| Cylinder Head Type | Cast Iron GT250, OHV |
| Cylinder Head | Ductile Iron |
| Cylinder Liners | Altronic CD1 |
| Piston Type | Aluminum |
| Crankshaft Type | Ductile Iron |
| Lifter Type | Solid |
| Intake Valve Material | Special Heat-Resistant Steel |
| Exhaust Valve Material | Alloy Steel, High Temp |
| Hardened Valve Seats | Alloy Steel, High Temp |

Engine Governing

| | |
|-------------------------------------|------------|
| Governor | Electronic |
| Frequency Regulation (Steady State) | +/- 0.25% |

Lubrication System

| | |
|------------------------------|---------------------|
| Oil Pump Type | Gear |
| Oil Filter Type | Full-Flow Cartridge |
| Crankcase Capacity - L (qts) | 34.3 (36.2) |

Cooling System

| | |
|---------------------------------|-----------------------------|
| Cooling System Type | Pressurized Closed Recovery |
| Water Pump Flow -gpm (lpm) | 110 (416) |
| Fan Type | Pusher |
| Fan Speed (rpm) | 1894 |
| Fan Diameter mm (in) | 762 (30) |
| Coolant Heater Wattage | 2000 |
| Coolant Heater Standard Voltage | 240 V |

Fuel System

| | |
|------------------------------------|---------------------------|
| Fuel Type | Natural Gas |
| Carburetor | Down Draft |
| Secondary Fuel Regulator | Standard |
| Fuel Shut Off Solenoid | Standard |
| Operating Fuel Pressure (Standard) | 7" - 11" H ₂ O |

Engine Electrical System

| | |
|-----------------------------|---------------------------------|
| System Voltage | 24 VDC |
| Battery Charging Alternator | Standard |
| Battery Size | See Battery Index 0161970SBY |
| Battery Voltage | (2)12 VDC |
| Ground Polarity | Negative |

ALTERNATOR SPECIFICATIONS

| | |
|-------------------------------------|-----------|
| Standard Model | 520mm |
| Poles | 4 |
| Field Type | Revolving |
| Insulation Class - Rotor | H |
| Insulation Class - Stator | H |
| Total Harmonic Distortion | <5% |
| Telephone Interference Factor (TIF) | <50 |

| | |
|------------------------------------|-----------------------|
| Standard Excitation | Permanent Magnet |
| Bearings | Sealed Ball |
| Coupling | Direct, Flexible Disc |
| Prototype Short Circuit Test | Yes |
| Voltage Regulator Type | Full Digital |
| Number of Sensed Phases | 3 |
| Regulation Accuracy (Steady State) | ±0.25% |

MG150 | 14.2L | 150 kW

INDUSTRIAL SPARK-IGNITED GENERATOR SET

EPA Certified Stationary Emergency

OPERATING DATA

POWER RATINGS

| | | Natural Gas |
|--------------------------------|--------|-------------|
| Three-Phase 120/208 VAC @0.8pf | 150 kW | Amps: 521 |
| Three-Phase 120/240 VAC @0.8pf | 150 kW | Amps: 452 |
| Three-Phase 277/480 VAC @0.8pf | 150 kW | Amps: 226 |
| Three-Phase 347/600 VAC @0.8pf | 150 kW | Amps: 181 |

STARTING CAPABILITIES (sKVA)

sKVA vs. Voltage Dip

| Alternator | kW | 480 VAC | | | | | | 208/240 VAC | | | | | |
|------------|-----|---------|-----|-----|-----|-----|-----|-------------|-----|-----|-----|-----|-----|
| | | 10% | 15% | 20% | 25% | 30% | 35% | 10% | 15% | 20% | 25% | 30% | 35% |
| Standard | 150 | 133 | 199 | 265 | 332 | 398 | 464 | 100 | 149 | 199 | 249 | 299 | 348 |
| Upsize 1 | 200 | 187 | 280 | 373 | 467 | 560 | 653 | 140 | 210 | 280 | 350 | 420 | 490 |

FUEL CONSUMPTION RATES*

Natural Gas - ft³/hr(m³/hr)

| Percent Load | Standby |
|--------------|-------------|
| 25% | 745 (21.1) |
| 50% | 1278 (36.2) |
| 75% | 1725 (48.8) |
| 100% | 2129 (60.3) |

* Fuel supply installation must accommodate fuel consumption rates at 100% load.

COOLING

| | | Standby |
|--|---|--------------|
| Air Flow (inlet air combustion and radiator) | ft ³ /min(m ³ /min) | 9349 (264.7) |
| Coolant Flow per Minute | g/min (l/min) | 110 (416) |
| Heat Rejection to Coolant | BTU/hr | 526,760 |
| Max. Operating Air Temp on Radiator | °F (°C) | 122 (50) |
| Max. Operating Ambient Temperature (before derate) | °F (°C) | 110 (43.3) |
| Maximum Radiator Backpressure | in H ₂ O | 0.5 |

COMBUSTION AIR REQUIREMENT

| | Standby |
|---|-----------|
| Flow at Rated Power cfm (m ³ /min) | 349 (9.9) |

ENGINE

| | | Standby |
|--------------------------|--------|------------|
| Rated Engine Speed | rpm | 1800 |
| Horsepower at Rated kW** | hp | 238 |
| Piston Speed | ft/min | 1949 (594) |
| BMEP | psi | 121 |

EXHAUST

| | | Standby |
|---|---------------------------|------------------------------|
| Exhaust Flow (Rated Output) | cfm (m ³ /min) | 1203 (34.1) |
| Max. Backpressure (Post Turbo) | inHg (Kpa) | 0.75 |
| Exhaust Temp (Rated Output - post silencer) | °F (°C) | 1350 (732) |
| Exhaust Outlet Size (Open Set) | (in) | 3.5" I.D .Flex (No Silencer) |

** Refer to "Emissions Data Sheet" for maximum bHP for EPA and SCAQMD permitting purposes.

Deration – Operational characteristics consider maximum ambient conditions. Derate factors may apply under atypical site conditions. Please consult a Generac Power Systems Industrial Dealer for additional details. All performance ratings in accordance with ISO3046, BS5514, ISO8528 and DIN6271 standards.

DIMENSIONS AND WEIGHTS*

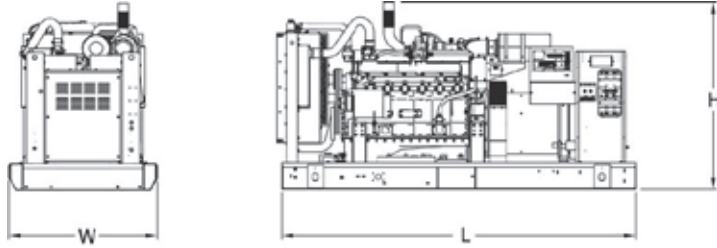

OPEN SET (Includes Exhaust Flex)

| | |
|---------------------|---|
| L x W x H (in (mm)) | 127.95 (3250) x 52.93 (1344.5) x 67.37 (1711.2) |
| Weight lbs (kg) | 5756 (2610.9) |

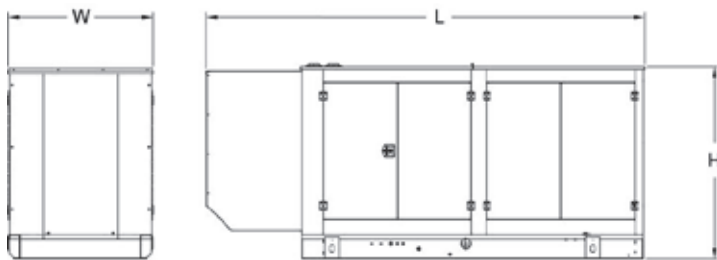

STANDARD ENCLOSURE

| | |
|---------------------|---|
| L x W x H (in (mm)) | 153.89 (3909) x 52.73 (1339.3) x 69.67 (1769.6) |
| Weight lbs (kg) | Steel: 6577 (2983) Aluminum: 6035 (2738) |

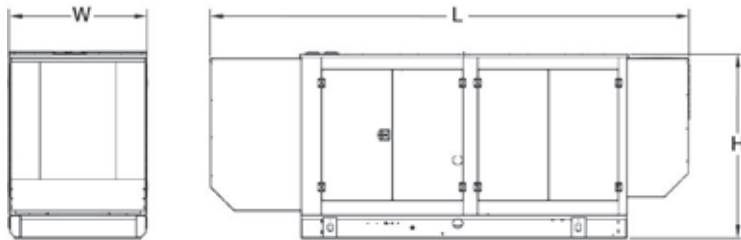

LEVEL 1 ACOUSTIC ENCLOSURE

| | |
|---------------------|---|
| L x W x H (in (mm)) | 180.11 (4574.7) x 52.73 (1339.3) x 69.67 (1769.6) |
| Weight lbs (kg) | Steel: 6990 (3171) Aluminum: 6176 (2801) |

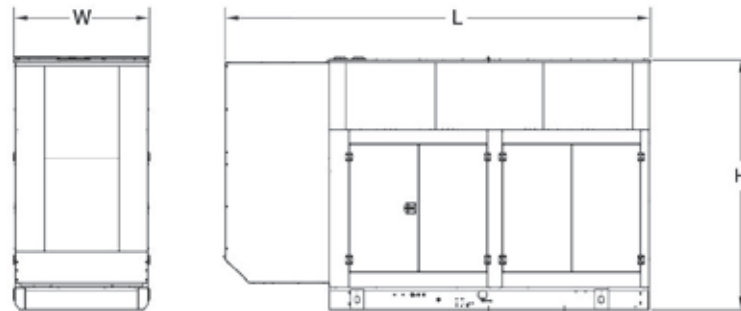

LEVEL 2 ACOUSTIC ENCLOSURE

| | |
|---------------------|---|
| L x W x H (in (mm)) | 154.45 (3922.9) x 53.96 (1370.6) x 93.40 (2372.3) |
| Weight lbs (kg) | Steel: 7236 (3282) Aluminum: 6259 (2839) |

* All measurements are approximate and for estimation purposes only.

YOUR FACTORY RECOGNIZED GENERAC INDUSTRIAL DEALER

Specification characteristics may change without notice. Please consult a Generac Power Systems Industrial Dealer for detailed installation drawings.