

MLTS

Light Tower Parts Manual

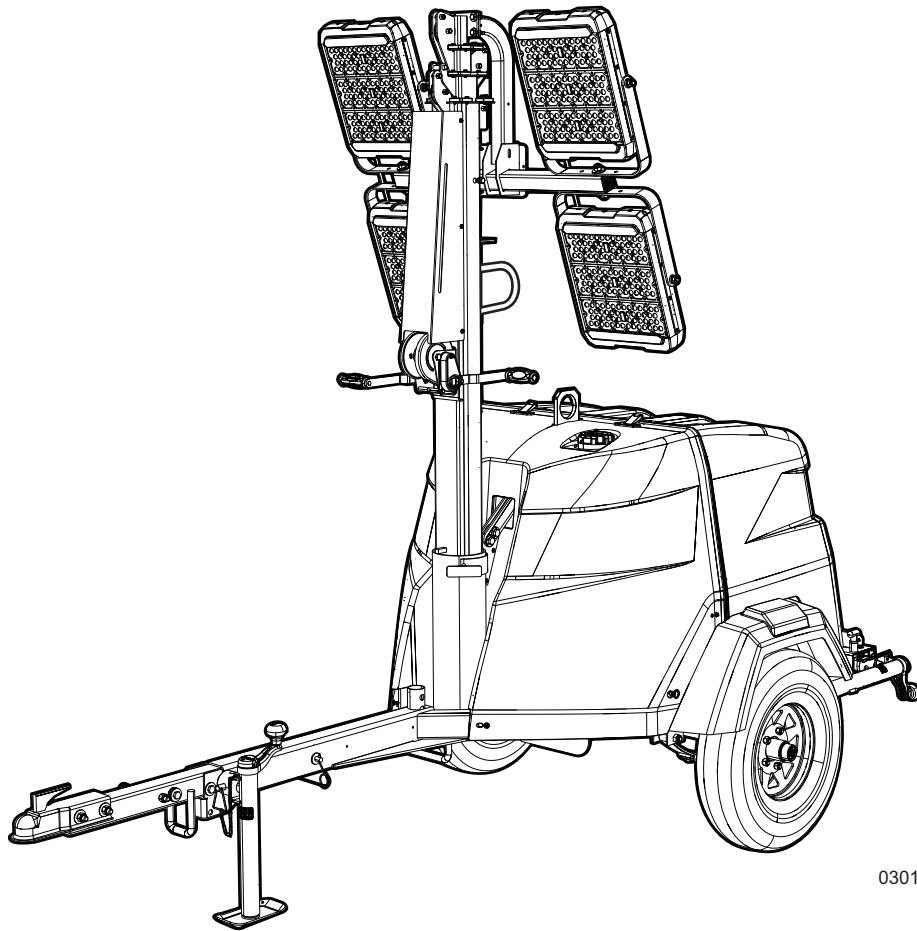

03019

MODEL NUMBER: _____

SERIAL NUMBER: _____

DATE PURCHASED: _____

SAVE THIS MANUAL FOR FUTURE REFERENCE

 **WARNING**

CANCER AND REPRODUCTIVE HARM

www.P65Warnings.ca.gov

(000393a)

 **WARNING**

Breathing diesel engine exhaust exposes you to chemicals known to the State of California to cause cancer and birth defects or other reproductive harm.

- Always start and operate the engine in a well-ventilated area.
- If in an enclosed area, vent the exhaust to the outside.
- Do not modify or tamper with the exhaust system.
- Do not idle the engine except as necessary.

For more information go to

www.P65Warnings.ca.gov/diesel

(000394)

Introduction

This parts manual was prepared based on the information available at the time of publication and is subject to change without notice. Generac Mobile Products reserves the right to change parts at any time. To check whether a revised parts manual is available, contact Generac Mobile Products.

DO NOT MODIFY or use this equipment for any application other than which it was designed for. To keep your equipment fully operational, it is suggested you maintain a stock of commonly used maintenance or service parts. A recommended spare parts list can be found in the back of this manual. To order service parts, please go to www.generacmobileproducts.com or call Generac Mobile Products.



WARNING

Consult Manual. Read and understand manual completely before using product. Failure to completely understand manual and product could result in death or serious injury. (000100a)

WARNING

Environmental Hazard. Always recycle batteries at an official recycling center in accordance with all local laws and regulations. Failure to do so could result in environmental damage, death, or serious injury. (000228)

GENERAC MOBILE PRODUCTS LLC

215 Power Drive • Berlin, WI 54923 U.S.A.

Phone: 920-361-4442

FAX: 920-361-4416

Toll Free: 1-800-926-9768

www.generacmobileproducts.com

For technical or parts QUESTIONS, contact Generac Mobile Products Technical Service at 1-800-926-9768.

Engine Make: _____

Engine Serial Number: _____

Engine Model Number: _____

This Page Intentionally Left Blank

Table of Contents

Introduction	iii
Parts Manual Instructions	1
Unit Decals - Front, Rear and Top.....	2
Unit Decals - Left and Right Sides.....	4
Unit Decals - Inside Unit.....	6
Mast, Junction Box and Lights to Unit	8
Light Assembly	10
Mast Junction Box Assembly - Hard Wired Lights.....	12
Diffused Lighting 320W (If Equipped).....	14
Mast Assembly	16
Mast Assembly - Bottom Post - Manual Winch	18
Enclosure Assembly (1 of 2).....	20
Enclosure Assembly (2 of 2).....	22
Control Box Assembly - Analog	24
Control Box Assembly - Digital (if Equipped).....	26
Analog Control Box Assembly With Shore Power (if Equipped)	28
Digital Control Box Assembly With Shore Power (if Equipped).....	30
Control Box Shore Power Panel (If Equipped)	32
Control Box Receptacle Panel (If Equipped)	34
Cooling System Assembly.....	36
Engine Assembly (1 of 2)	38
Engine Assembly (2 of 2)	40
Engine and Generator to Unit.....	42
Generator	44
Components to Trailer Assembly (1 of 2).....	46
Components to Trailer Assembly (2 of 2).....	48
Trailer Assembly.....	50
Recommended Spare Parts - Engine and Service Kits.....	52
Recommended Spare Parts - Misc.....	54

This Page Intentionally Left Blank

Parts Manual Instructions

Product illustrations are only representations. Products supplied may vary from the illustrations in this parts manual. Parts not shown in the illustration are indicated by a double dash (--) in the item column.

Please be prepared to provide the following information when ordering replacement parts: model number, serial number (on unit serial tag), part number, purchase order number (if applicable), shipping address, shipping method.

Refer to the illustration below to locate the unit ID tag and Vehicle Identification Number (VIN) tag on the unit. Important information, such as the unit serial number, model number, VIN and tire loading information are found on these tags. Record the information from these tags so it is available if the tags are lost or damaged. When ordering parts or requesting assistance, you may be asked to provide this information.

VIN Tag

MANUFACTURED BY/ABBREVIATED NAME: Generac Mobile Products LLC		DATE: 000000	TIRE AND LOADING INFORMATION WEIGHTS AND LOADS PLEASE SEE CHANGEMENTS The weight of cargo should never exceed 5000KG (11000LBS) in total. An changeover on date of last inspection: 00/00/00
GVS/NP/NV: 0000 000000 DATE: / / TIME: : : DIM / ANTE: / /	COLD INF. PRESS./ PRESS. DE CONF. APPROV. / MP/SP/LL/CP/CSL/CS/CL		
EACH PAGE	SEE OWNERS MANUAL FOR ADDITIONAL INFORMATION		VEHICLE IDENTIFICATION NUMBER MODEL: XXX000 TYPE: TRAILER
VIN: 000000000000000000			

Unit ID Tag (Located on top of control box)

Manufactured by Generac Mobile Products LLC			(000) 341-4442	(000) 000-0700
Country of Origin	Model	Serial Number		
Manufacturing Code	Weight (lbs/kg)	GPH/Frequency		
1 pin, 1.0PF	3 pin, 0PF	3 pin, 1.0PF	Rating	
KW			Vol. Class	
KVA				
V				
A				

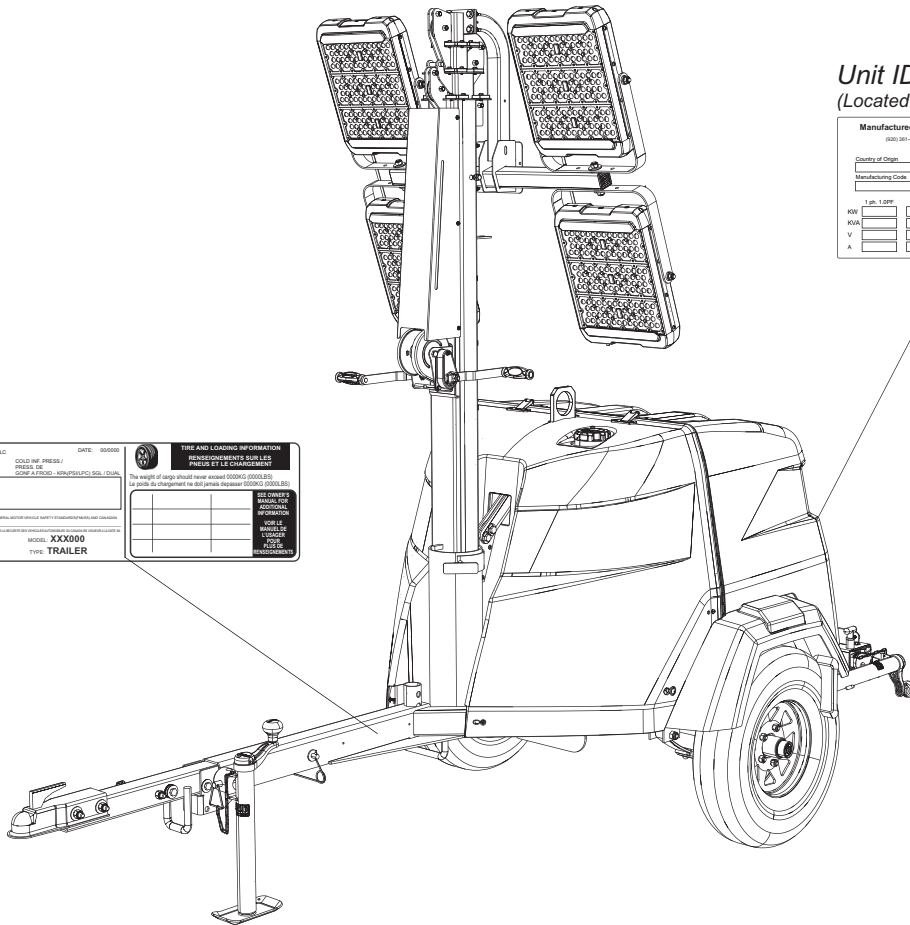

03020

UNIT DECALS - FRONT, REAR AND TOP

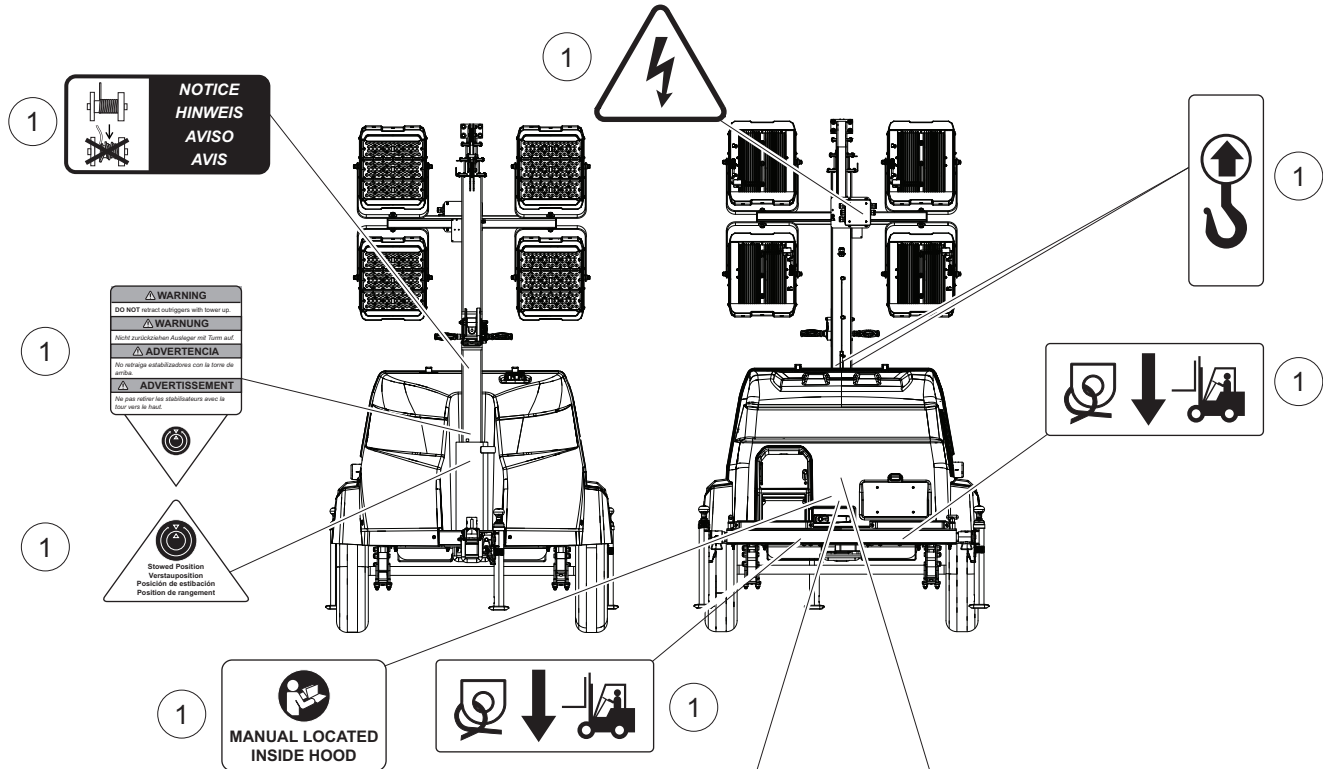

2

ENGINE OPERATION
MOTORBETRIEB
OPERACION DEL MOTOR
FONCTIONNEMENT DU MOTEUR

MANUAL LOCATED INSIDE HOOD

1 2 3

SHUTDOWN
ABSCHALTUNG
APAGADO
ARRÊT

1 2

STOP

3

ENGINE OPERATION
MOTORBETRIEB
OPERACION DEL MOTOR
FONCTIONNEMENT DU MOTEUR

MANUAL LOCATED INSIDE HOOD

1 2 3

SHUTDOWN
ABSCHALTUNG
APAGADO
ARRÊT

1 2

CONTROL POWER

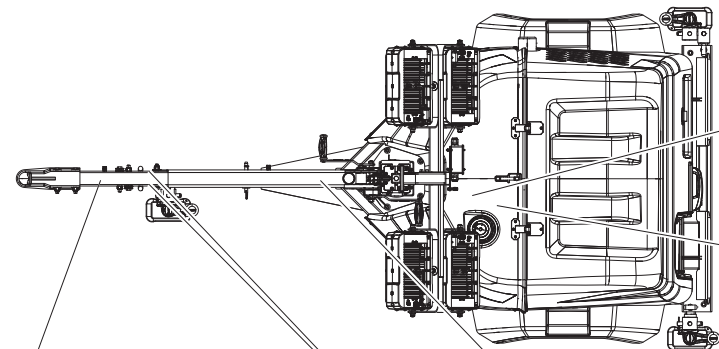

1

DANGER
GEFAHR
PELIGRO
DANGER

DIESEL

1

ULTRA LOW SULFUR FUEL ONLY

S≤15 mg/kg

4

<p>TOWING INSTRUCTIONS</p> <ol style="list-style-type: none"> Read operator's manual. Use hitch rated for trailer's "gross vehicle weight rating". Securely attach trailer to tow vehicle. Attach safety chains using a cross pattern. Attach breakaway chain to vehicle. Check trailer lights. 	<p>ABSCHLEPPANWEISUNGEN</p> <ol style="list-style-type: none"> Benutzerhandbuch lesen. Anhängereinstellung verwenden, die der "Gesamteinheitsgewichtsklassen" des Fahrzeuges entspricht. Abschleppfahrzeug befestigen. Sicherheitsketten über Kreuz anbringen. Abrastkette am Fahrzeug anbringen. Anhängerleuchten prüfen. 	<p>INSTRUCCIONES PARA REMOLQUE</p> <ol style="list-style-type: none"> Leer el manual del operador. Use un enganche adecuado para la "capacidad de peso bruto del vehículo" del remolque. Enganche firmemente el remolque a vehículo del remolque. Enganche las cadenas de seguridad en forma cruzada. Enganche al vehículo la cadena de emergencia para anclaje. Revisar las luces del remolque. 	<p>INSTRUCTIONS DE REMORQUAGE</p> <ol style="list-style-type: none"> Lire le manuel de l'utilisateur. Utiliser un étrépage convenant au poids maximal du véhicule remorqué. Arrimer solidement le remorque au véhicule tracteur. Fixer les chaînes de sécurité en les croisant. Fixer la chaîne de remorque au véhicule. Vérifier les feux de la remorque.
--	---	---	---

45 mph

1

1

UNIT DECALS - FRONT, REAR AND TOP

Item	Part No.	Qty	Description	Notes
1	55016	1	DECAL, SAFETY	
2	10000036934	1	DECAL ENGINE OPERATION	
3	10000039507	1	DECAL, OPERATION - PZ	
4	A0002688141	1	DECAL, TOWING INSTRUCTIONS	

UNIT DECALS - LEFT AND RIGHT SIDES

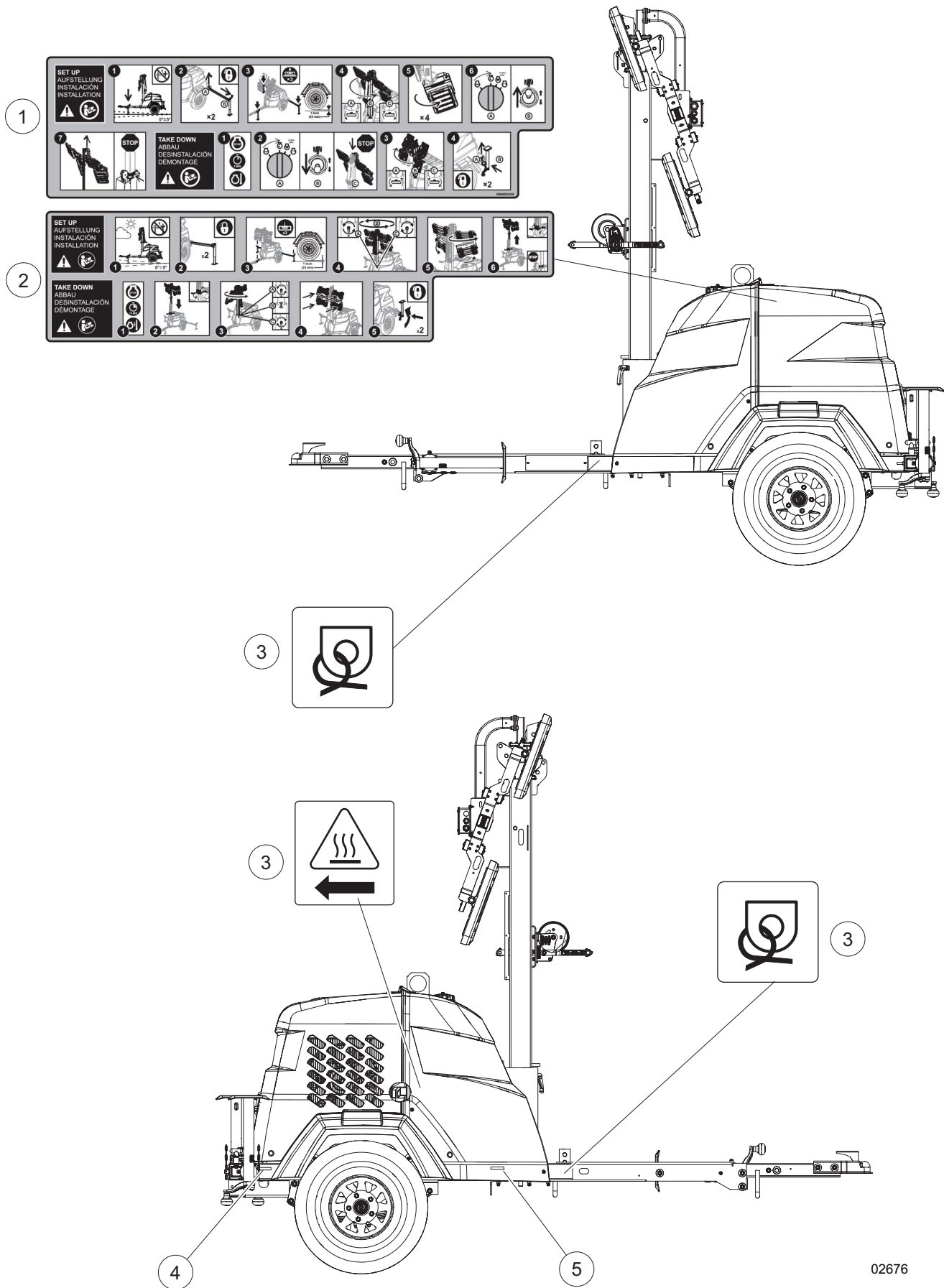

02676

UNIT DECALS - LEFT AND RIGHT SIDES

Item	Part No.	Qty	Description	Notes
1	10000035325	1	DECAL, OPERATION MLT6SM - SKDS (ELECTRIC)	
2	10000035402	1	DECAL, OPERATION MLT6SM - SKDS (MANUAL)	SHOWN
3	55016	1	DECAL, SAFETY MLT6SMD	
4	72149	1	REFLECTOR, RED (4.25 IN X .75 IN)	SET OF TWO
5	72150	1	REFLECTOR, YELLOW (4.25 IN X .75 IN)	SET OF TWO

UNIT DECALS - INSIDE UNIT

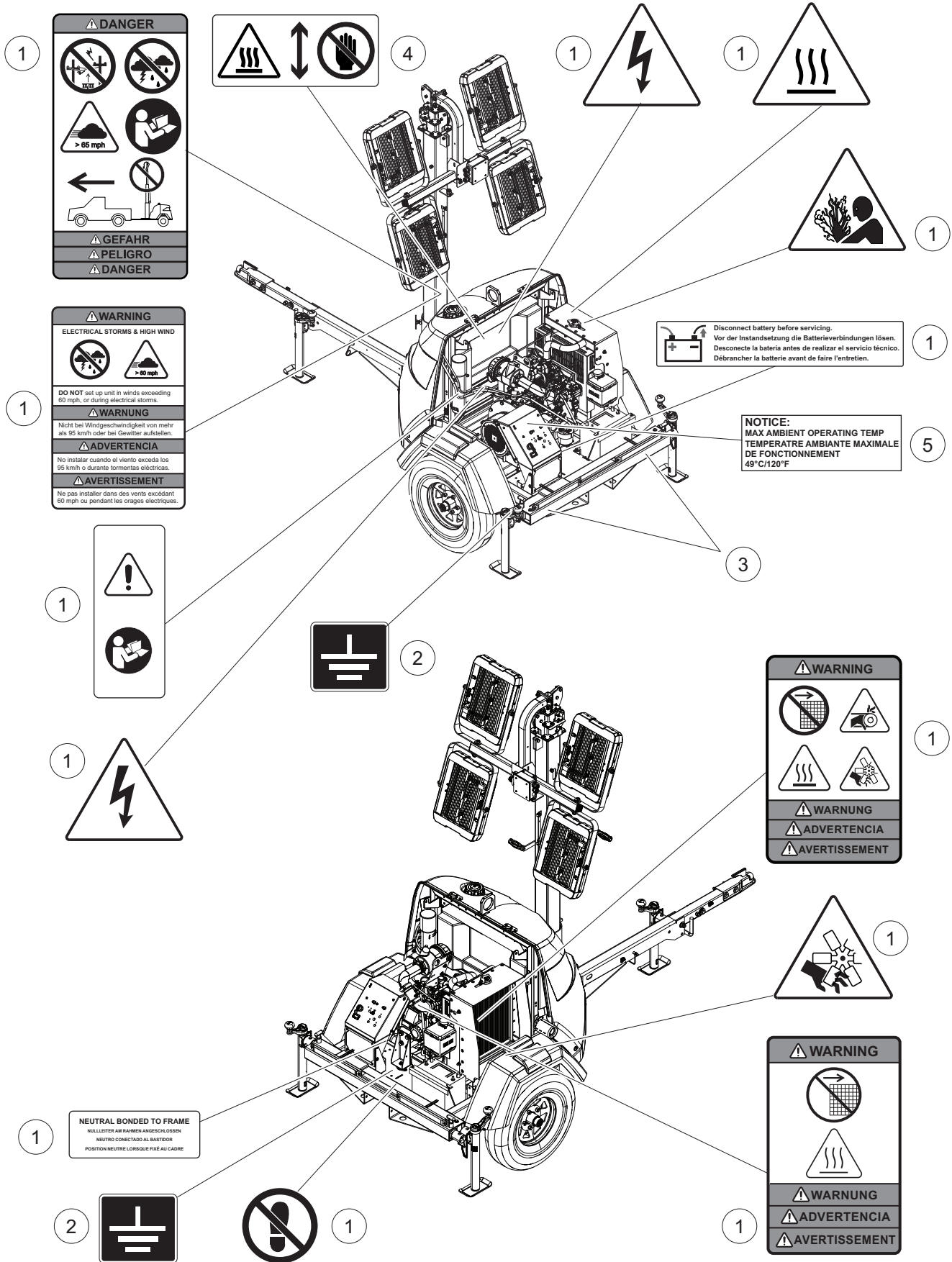

03913

UNIT DECALS - INSIDE UNIT

Item	Part No.	Qty	Description	Notes
1	55016	1	DECAL, SAFETY MLT6SMD	
2	12142	1	DECAL, GROUND	
3	72132	1	REFLECTOR, REAR 2.0 X 2.0 - RED	SET OF TWO
4	A0000116250	1	DECAL, HOT EXHAUST ABOVE	
5	A0005111231	1	DECAL, NOTICE - MAX AMBIENT 49°C-120°F	

MAST, JUNCTION BOX AND LIGHTS TO UNIT

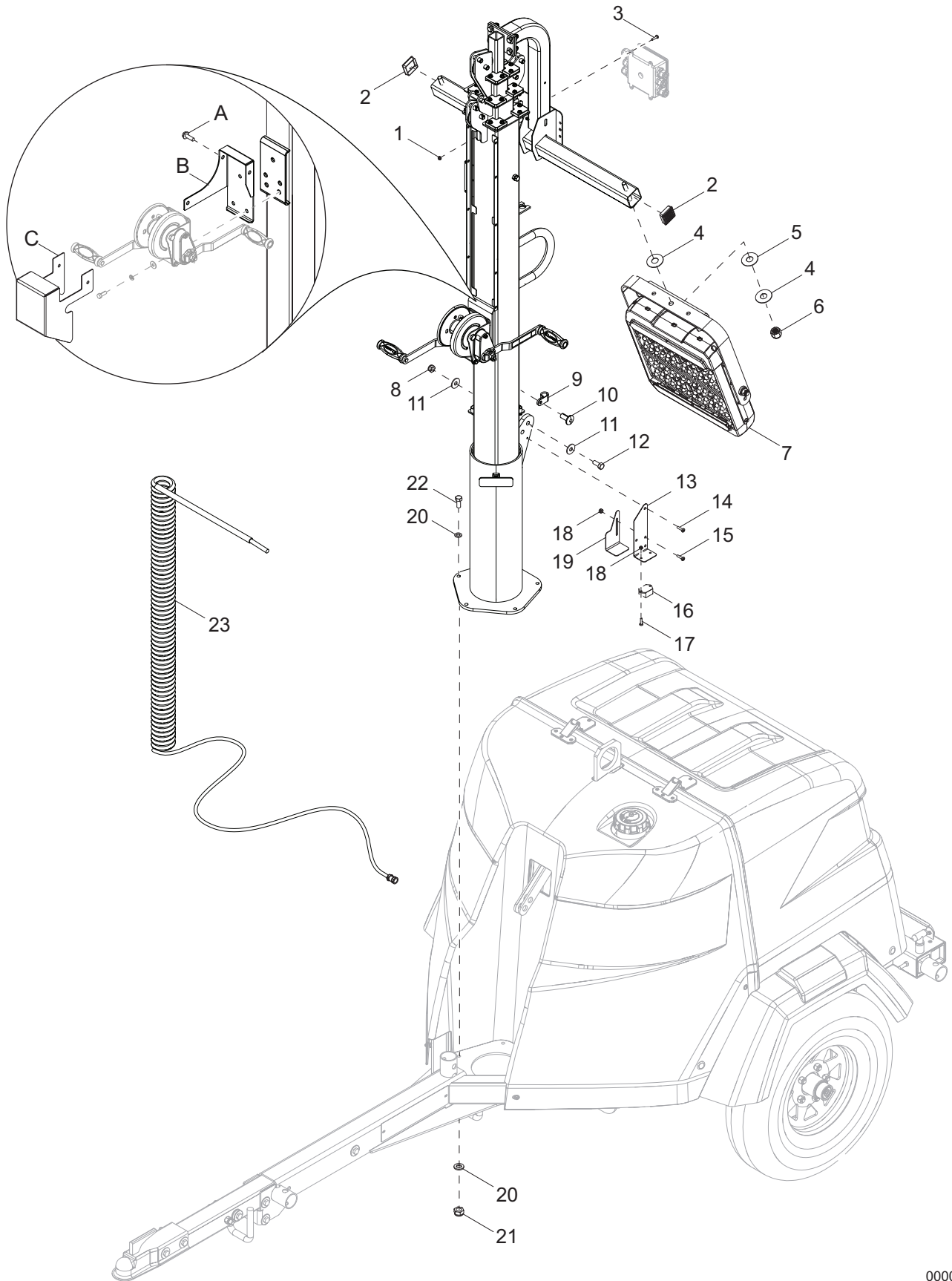

00000

MAST, JUNCTION BOX AND LIGHTS TO UNIT

Item	Part No.	Qty	Description	Notes
1	60061	4	NUT, 10-32 NYLOCK, ZC	
2	10000023259	2	PLUG, 2.0 SQUARE X .14 GA TUBE, PLASTIC	
3	60062	4	SCREW, 10-32 X .750 PAN PHILLIPS, G2	
4	A0000221212	8	WASHER FLAT M12 X 37OD X 1.5THK NYLON	
5	G052259	4	WASHER FLAT M12	
6	0D7119	4	NUT HEX LOCK M12-1.75 NY INS	
7	A0001904532	4	ASSY LED LIGHT HARD WIRE 320W	
8	62221	2	NUT, .500-13 NYLOCK, G5	
9	60375	3	CLAMP, TUBING - .312 LT DUTY	
10	60268	3	RIVET, .188 DIA X .126 TO .250 GRIP SSB6-4S	
11	G022304	4	WASHER FLAT 1/2 ZINC	
12	60484	2	SCREW, .500-13 X 2.0 STANDARD HEX, G5	
13	70208B	1	BRACKET, NIGHT WATCHMAN	
14	G036937	2	SCREW PPHM #10-32 X 1	
15	62054	2	SCREW, 8-32X.500 PAN PHIL 18-8 SS	
16	68763	1	ASSEMBLY, NIGHT WATCHMAN	
17	62054	2	SCREW, 8-32 X .500 PAN PHILLIPS 18-8, SS	
18	60270	8	NUT, 8-32 NYLOCK	
19	56610B	1	COVER, DUSK TO DAWN SENSOR	
20	60386	10	WASHER, .375 FLAT .993/.064	
21	60358	5	NUT, .375-16 NYLOCK, G5	
22	60139	5	SCREW, .375-16 X 1.50 HEX, G5	
23	A0000098118	1	ASSEMBLY, COIL CORD	

MAST WINCH COVER OPTION (If equipped):

A	60528	4	SCREW, .250-20X.625 SFLG HEX G5 ZC
B	A0004064495	1	ASSY-PLATE-MANUAL WINCH
C	A0000527662	1	STB COVER, MANUAL WINCH - MLT6/8S

LIGHT ASSEMBLY

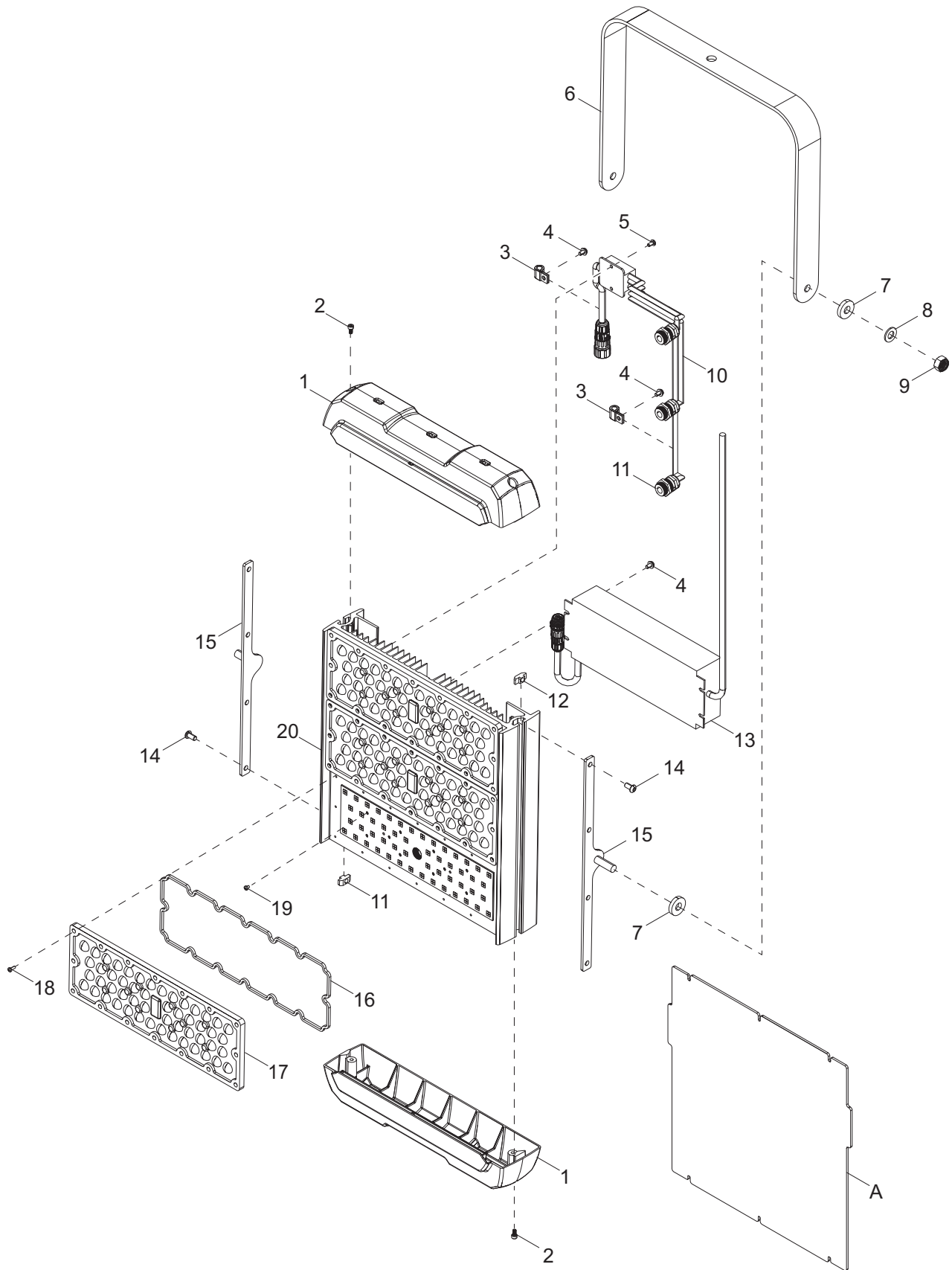

03022

LIGHT ASSEMBLY

Item	Part No.	Qty	Description	Notes
1	A0000092362	2	END CAP, WITH DIFFUSER SLOT	
2	A0000188756	4	SCREW, M4-.7 X 12	
3	G020151	2	CLAMP, .312 X .302 - STEEL/VINYL	
4	0G7070	6	SCREW, M4-.7 X 14 PPHM	
5	G020745	2	SCREW, M4-.7 X 12 PPHM	
6	A0000188712	1	BRACKET, TRUNNION - 320W	
7	A0000188752	4	WASHER, M10 ID X 25MM OD X 5 MM T	
8	60027	2	WASHER, M10 FLAT	
9	A0000009451	2	NUT, M10-1.50 NYLOCK, G8.8	
10	A0000188731	1	CABLE, 2 POSITION, 3 WAY SPLITTER	
11	A0000092266	3	STRAIN RELIEF, 320W LED	
12	A0000188739	8	NUT, M6-1.00 X 12 HAMMER	
13	A0000188779	1	ASSEMBLY, DRIVER WITH CONNECTOR	
14	A0000214354	8	SCREW, M6-1.0 X 12 BHSC - BLACK	
15	A0000095202	2	BRACKET, TRUNNION TO FRAME	
16	A0000092361	3	GASKET, OPTICAL LENS SEAL	
17	A0000092360	3	LENS, OPTICAL 60°	
18	A0000192578	48	SCREW, MOUNTING - OPTICAL LENS	
19	A0000192575	30	SCREW, MOUNTING - PCB	
20	A0000092179	1	FRAME, HEAT SINK 320W - LED	

Diffused Lighting (If equipped):

A	A0000095669	1	KIT, DIFFUSER LENS 320W - LED	
--	A0000277071	1	KIT, DIFFUSER LENS STORAGE 320W - LED	

MAST JUNCTION BOX ASSEMBLY - HARD WIRED LIGHTS

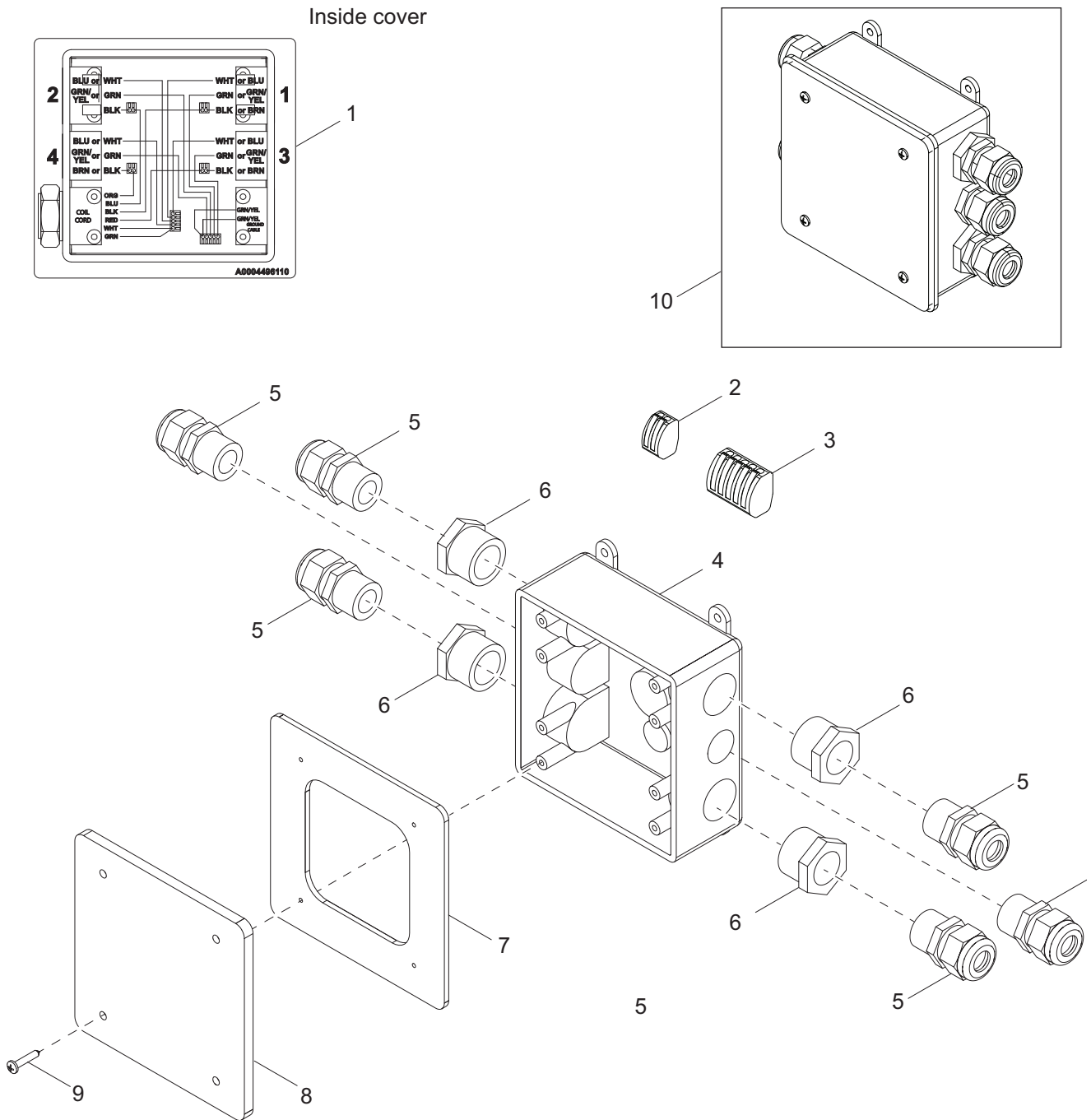

02607

MAST JUNCTION BOX ASSEMBLY - HARD WIRED LIGHTS

Item	Part No.	Qty	Description	Notes
1	A0004496110	1	DECAL, MAST JUNCTION BOX	
2	66100	4	CONNECTOR, 2 POSITION	
3	66102	2	CONNECTOR, 5 POSITION	
4	12094	1	BOX, JUNCTION	
5	60755	3	FITTING, STRAIGHT .750MNPT X .500FNPT, NYL	
6	15864	5	STRAIN RELIEF, .500NPT WATER TIGHT	
7	13749SRV	1	GASKET, JUNCTION BOX - HFI 281000	
8	12109	1	COVER, BOX, 2-GANG PLASTIC	
9	60424	4	SCREW, 6-32 X .750 PAN PHILLIPS, G2	
10	A0000073922	1	ASSEMBLY, MAST JUNCTION BOX	

DIFFUSED LIGHTING 320W (IF EQUIPPED)

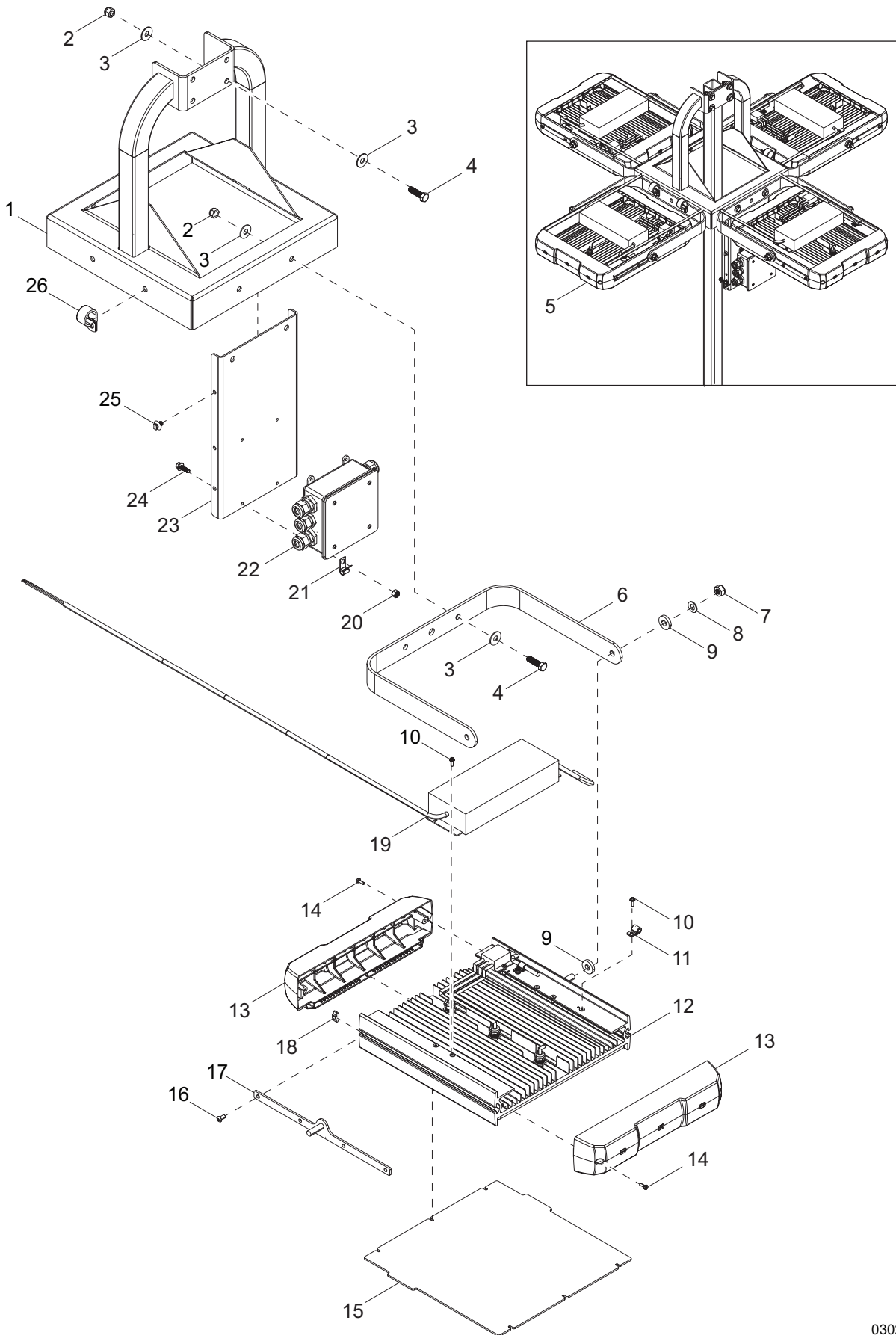

03023

DIFFUSED LIGHTING 320W (IF EQUIPPED)

Item	Part No.	Qty	Description	Notes
1	10000035385	1	WELDMENT, MOUNT 4 - DIFFUSED	
2	60358	12	NUT, .375-16 NYLOCK, G5	
3	60386	24	WASHER, .375 FLAT .993/-.64	
4	60352	12	SCREW, .375-16 X 1.250 HEX, G5	
5	A0001500725	1	ASSEMBLY, DIFFUSED LIGHTING 320W	
6	A0000188712	1	BRACKET, TRUNNION	
7	A0000009451	2	NUT, M10-1.50 NYLOCK, G8.8	
8	60027	2	WASHER, M10 FLAT	
9	A0000188752	4	WASHER, M10 ID X 25MM OD X 5MM T	
10	0G7070	5	SCREW, PPHM M4A0.7 X 14 SEMS	
11	G020151	2	CLAMP, .312 X .203	
12	A0000188772	1	ASSEMBLY, 320W MODULE - LED	
13	A0000092362	2	END CAP, W/DIFFUSER SLOT	
14	A0000188756	4	SCREW, M4-0.7 X 12	
15	A0000095669	1	LENS, DIFFUSER 320W - LED	
16	A0000214354	8	SCREW, M6-1.0 X 12 BUTTON HEAD HEX - BLACK	
17	A0000095202	2	BRACKET, TRUNNION TO FRAME	
18	A0000188739	8	NUT, M6-1.00 X 12 HAMMER	
19	A0000188779	1	ASSEMBLY, DRIVER WITH CONNECTOR	
20	60787	4	NUT, .250-20 NYLOCK - SS	
21	60375	1	CLAMP, TUBING .312 - LIGHT DUTY	
22	A0000073922	1	ASSEMBLY, MAST JUNCTION BOX	
23	10000035367	1	BRACKET, J BOX MOUNT	
24	60107	4	SCREW, .250-20 X .750 SERRATED FLNG HEX, G5	
25	66685	4	MOUNT, CABLE TIE .25-28 DIA. .031-.270 GRIP	
26	34552	4	CLAMP, TUBING 1.00HD, .406 HOLE, .75WD	
--	A0000098118	1	ASSEMBLY, COIL CORD	

MAST ASSEMBLY

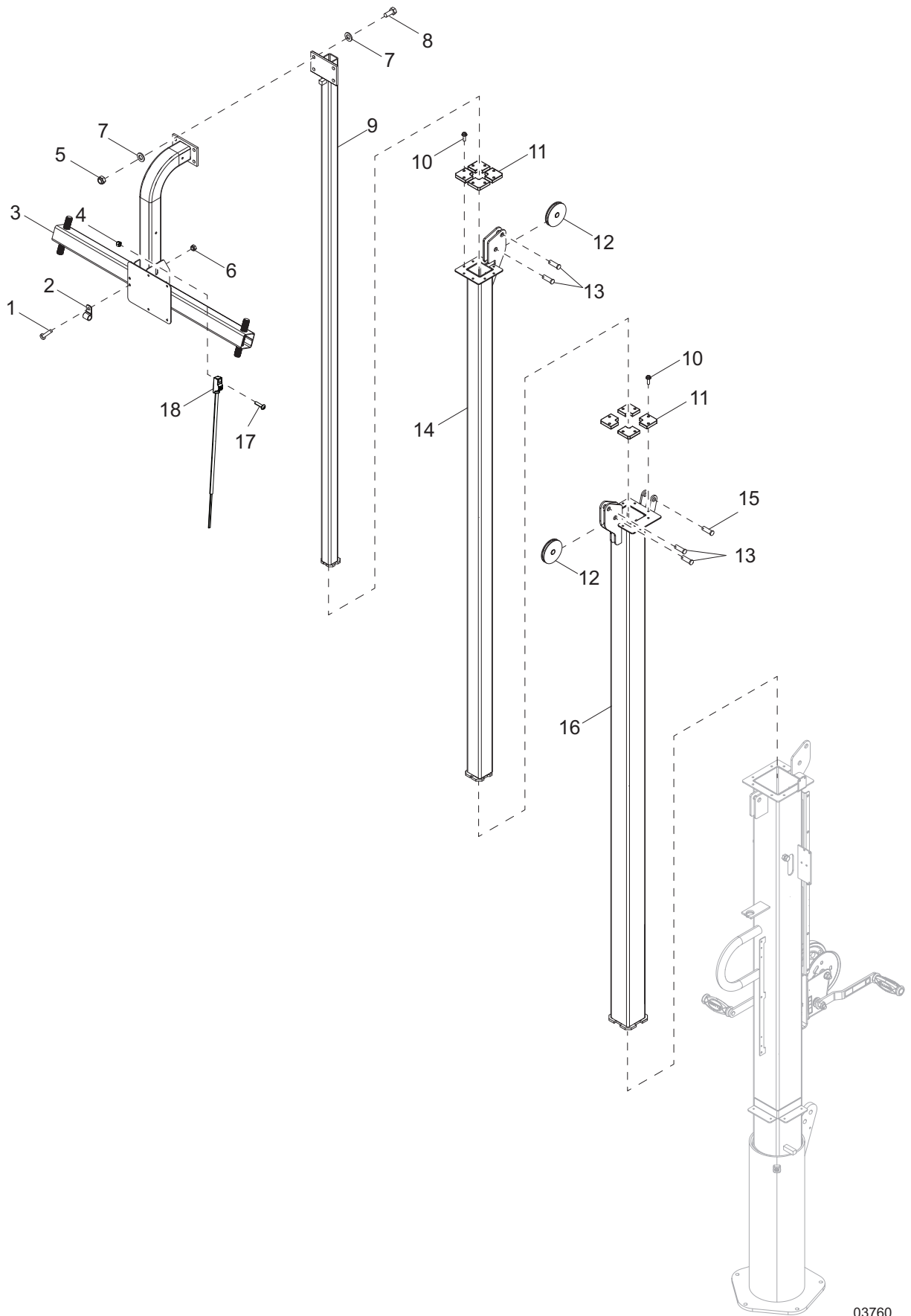

03760

MAST ASSEMBLY

Item	Part No.	Qty	Description	Notes
1	60061	1	NUT, .250-20 NYLK 18-8 SS	W/A0001500722
2	16143	1	CLAMP, TUBING .312 - LT DUTY	W/A0001500722
3	A0000199129	1	STB WELDMENT MAST CROSSARM	
4	0E6480	1	NUT HEX LOCK M4-0.7 NY INS	
5	60358	4	NUT, .375-16 NYLOCK, G5	
6	60062	1	SCREW .250-20X.750 SFLG HEX G5	W/A0001500722
7	60698	8	WASHER, .375 FLAT .993/.064	
8	60352	4	SCREW, .375-16 X 1.250 HEX, G5	
9	31264B	1	WELDMENT, MAST - 1.50	
10	63358	16	SCREW, .250-20 X .625 HEX WASH HD	
11	31225	8	GUIDE	
12	33736	2	ASSEMBLY, PULLEY - VERTICAL MAST	
13	63325	4	PIN, CLEVIS .500 DIAMETER X 1.063 UL	
14	31261B	1	WELDMENT, MAST - 2.25	
15	35655	1	PIN, CLEVIS .500 DIAMETER X 1.750 ZP	
16	A0002848667	1	STB WELDMENT MAST 3.00	
17	G075476	1	SCREW PPHM M4-0.7 X 16	
18	A0002233216	1	ASM CABLE MOLDED GROUND TERMINAL	
--	31247	1	CABLE, .188 X 144 W/BALL SWEDGE	WINCH CABLE
--	31248	1	CABLE, .188 X 79.750 W/BALL SWEDGE	MIDDLE CABLE
--	31277	1	CABLE, .188 X 78.0 W/BALL SWEDGE	TOP CABLE

MAST ASSEMBLY - BOTTOM POST - MANUAL WINCH

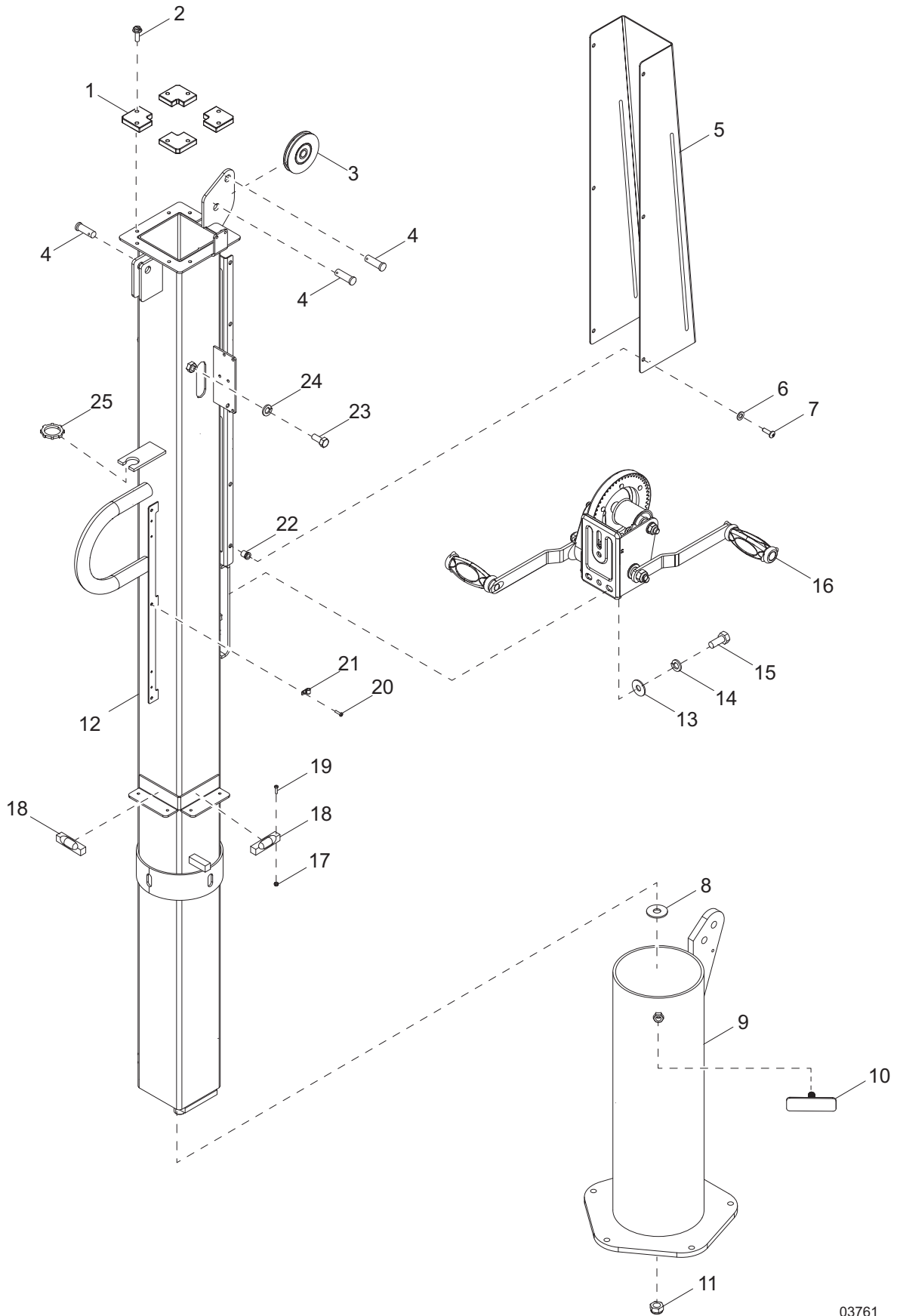

03761

MAST ASSEMBLY - BOTTOM POST - MANUAL WINCH

Item	Part No.	Qty	Description	Notes
1	31225	4	GUIDE	
2	63358	8	SCREW, .250-20 X .625 HEX WASHER HEAD	
3	33736	1	ASSEMBLY, PULLEY VERTICAL MAST	
4	63325	3	PIN, CLEVIS .500 DIAMETER X 1.063 UL	
5	72116B	1	CABLE GUARD, MANUAL WINCH	
6	60067	6	WASHER, #10 FLAT .435/.060 18-8 SS	
7	60398	6	SCREW, 10-32X.500 PAN PHIL18-8 SS	
8	60247	1	WASHER, .750 FLAT 2.020/.130	
9	31218B	1	WELDMENT, MAST ROTATION TUBE	
10	10000018317	1	STZY WELDMENT T HANDLE	
11	60584	1	NUT, .750-10 NYLOCK, G5	
12	A0002749456	1	STB WELDMENT MAST 4.00	
13	60386	3	WASHER. .375 FLAT .993/.064	
14	60206	3	WASHER, .375 SPLIT LOCK - HARDENED	
15	60205	3	SCREW, .375-16 X 1.0 HEX, G5	
16	72127	1	WINCH, MANUAL - 1500 LB, DUAL HANDLE	
17	60051	4	NUT, M4-.70 NYLK G8.8 ZC	
18	A0000764090	2	LEVEL- SPIRIT	
19	A0000945464	4	SCREW PFHM M4-0.7 X 25 18-8 SS	
20	60268	3	RIVET, .188 DIA X .126 TO .250 GRIP SS	
21	60375	3	CLAMP, TUBING - .312 LT DUTY	
22	32922	6	INSERT, THD #10-32 SPLINED .020-.130 GR	
23	62269	2	SCREW, .375-16X.75 STD HEX 18-8 SS, RED	
24	60703	2	WASHER, .375 SPLIT LOCK 18-8 SS	
25	15861	1	NUT, SPECIAL .500 NPT LOCK	

ENCLOSURE ASSEMBLY (1 OF 2)

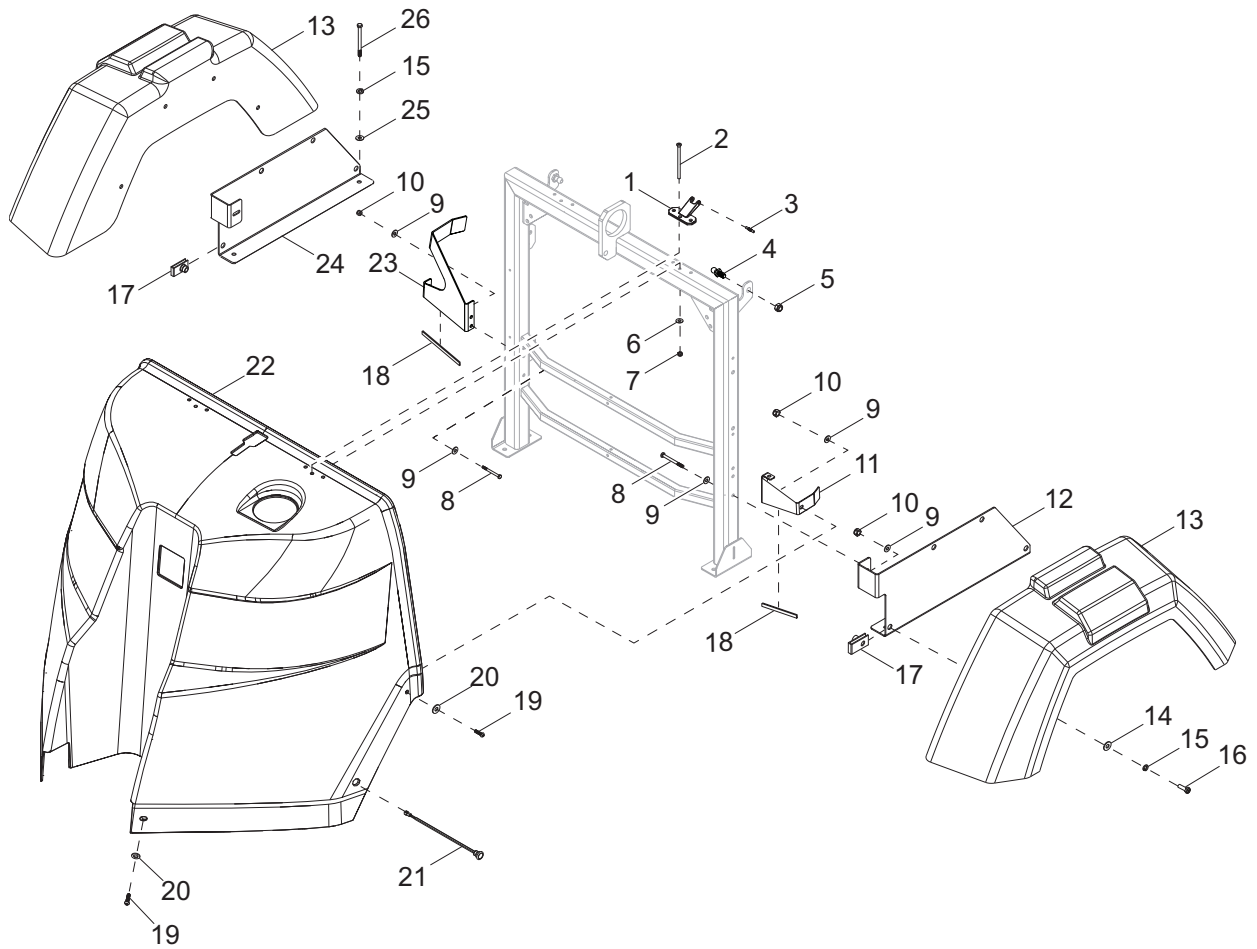

02435

ENCLOSURE ASSEMBLY (1 OF 2)

Item	Part No.	Qty	Description	Notes
1	10000022542	2	HINGE, OFFSET HOUSING LEAF - FRONT	
2	35282	6	SCREW, 10-24 X 3.0 FLAT HEAD PHILLIPS, SS	
3	10000022543	2	PIN, OFFSET HOUSING HINGE - KNURLED	
4	35293	2	BALL STUD, 10MM, .313-18	
5	60303	2	NUT, .312-18 NYLOCK, G2	
6	60237	12	WASHER, #10 FLAT .495/.036	
7	60457	12	NUT, 10-24 NYLOCK, G2	
8	61234	6	SCREW, .250-20 X 2.750 STANDARD HEX, G5	
9	60243	12	WASHER, .250 FLAT .735/.060	
10	60144	8	NUT, .250-20 NYLOCK, G5	
11	10000017357	1	GUIDE BRACKET, ENCLOSURE MEETING -LH	
12	35141B	1	BRACKET, MOUNTING FENDER - LEFT	
13	10000017287	2	FENDER, PLASTIC, 13 IN. WHEEL	
14	60386	8	WASHER, .375 FLAT .993/.064	
15	60271	8	WASHER, .312 SPLIT LOCK	
16	60028	8	SCREW, .312-18 X 1.0 STANDARD HEX, G5	
17	62086	8	NUT, .312-18 U-CLIP - SHORT TYPE	
18	68070	4	SCREW, .250-20 X 1.00 BUTTON HEX, SS	
19	60696	6	WASHER, .250 FLAT .625/.050, SS	
20	36961	2	ASSEMBLY, AMBER SIDE MARKER LIGHT	
21	10000012597	1	ENCLOSURE, FRONT COVER	
22	10000017378	1	GUIDE BRACKET, ENCLOSURE MEETING -RH	
23	35216B	2	BRACKET, MOUNTING FENDER - RIGHT	
24	60119	6	WASHER, .312 FLAT .875/.070	
25	60404	4	SCREW, .312-18 X 1.250 STANDARD HEX, G5	

ENCLOSURE ASSEMBLY (2 OF 2)

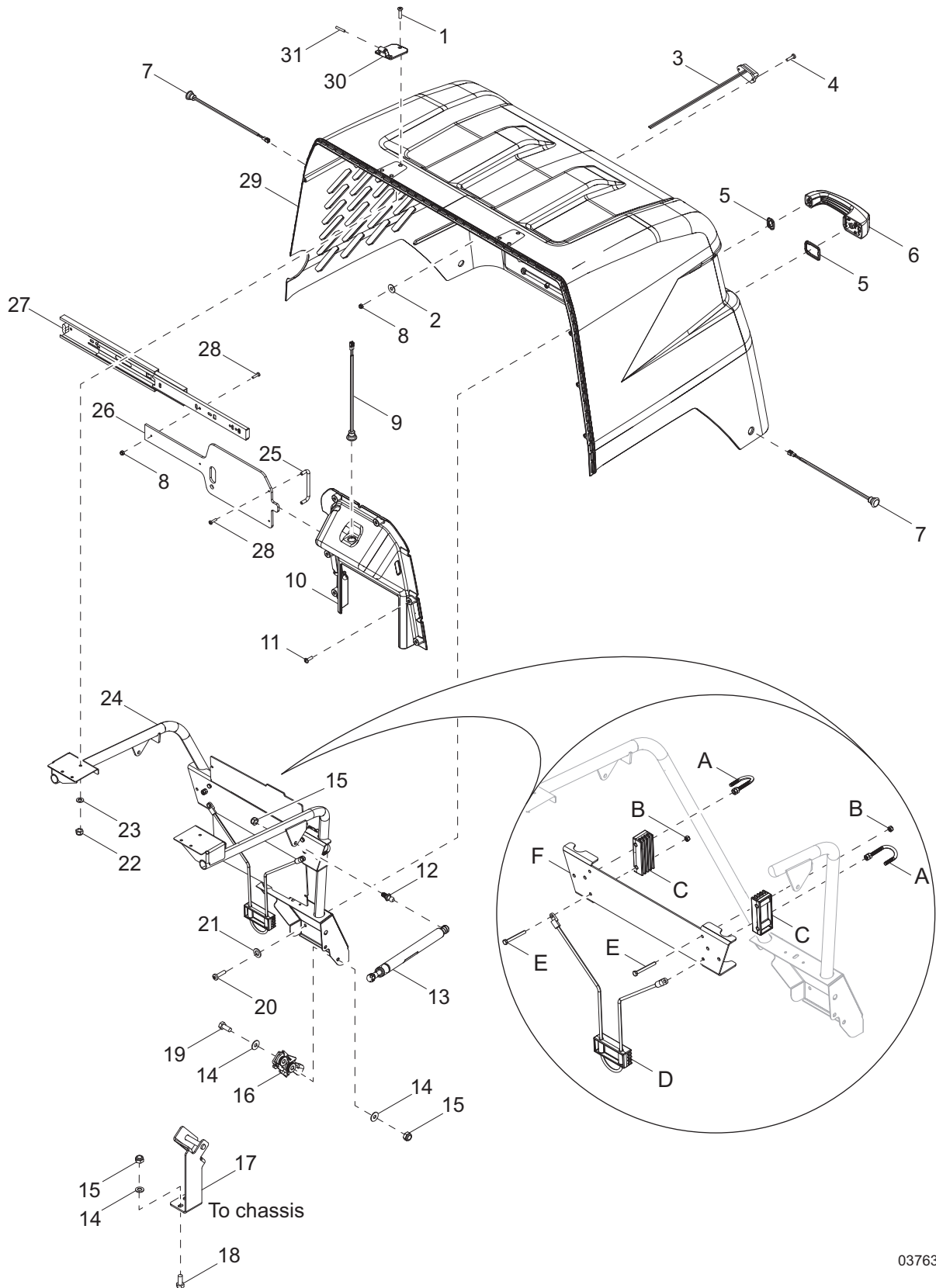

03763

ENCLOSURE ASSEMBLY (2 OF 2)

Item	Part No.	Qty	Description	Notes
1	35290	6	SCREW, 10-24 X 1.00 FLAT PHILLIPS, SS	
2	60269	2	WASHER, #8 FLAT .433/.036 ZC	
3	A0001653096	1	LIGHT LICENSE PLATE W/ CONNECTORS	
4	60694	2	SCREW, 8-32 X .750 PAN PHILLIPS, SS	
5	70216	1	GASKET, KIT HANDLE, PUSH BUTTON	
6	35138	1	HANDLE, PUSH-BUTTON PADLOCK	
7	36962	2	ASSEMBLY, RED SIDE MARKER	
8	60270	4	NUT, 8-32 NYLOCK, CLASS 6	
9	36964	1	ASSEMBLY, CONTROLS LIGHT	
10	10000012596	1	BEZEL, CONTROL PANEL TEXTURED - BLACK	
11	10000017348	6	SCREW, D60-2.14 X 20TRWH	
12	35293	2	BALL STUD, 10MM, .313-18	
13	35137	2	GAS SHOCK, 120 LB	
14	60119	6	WASHER, .312 FLAT .875/.070	
15	60303	6	NUT, .312-18 NYLOCK, G2	
16	35139	1	LATCH, ROTARY	
17	37178B	1	MOUNT, DOOR LATCH STRIKER	
18	61066	2	SCREW, .312-18 X 1.00 CARRIAGE SQUARE - SS	
19	62001	2	SCREW, .312-18 X 1.250 STANDARD HEX, G5	
20	60146	3	SCREW, M6-1.00X20 PAN PHIL G4.8 ZC	
21	60243	3	WASHER, .250 FLAT .735/.060	
22	60457	6	NUT, 10-24 NYLOCK, G2 ZC	
23	60237	6	WASHER, #10 FLAT .495/.036 ZC	
24	37012B	1	WELDMENT, ENCLOSURE STRUCTURE	
25	37123	1	HANDLE, CONTROL BOX COVER	
26	10000017623	1	COVER, SLIDING CONTROL PANEL	
27	36914	1	SLIDE, CONTROL BOX COVER	
28	62054	4	SCREW, 8-32 X .500 PAN PHILLIPS - SS	
29	10000017682	1	HOUSING REAR TEXTRD WHT	
30	10000022523	2	HINGE, LEAF OFFSET HOUSING - REAR	
31	10000022543	2	HINGE OFFSET HOUSING KNURLED PIN	

LED LENS DIFFUSER STORAGE (If equipped):

A	A0000277098	2	U-BOLT M6X1 SS
B	60047	4	NUT, M6-1.00 HEX NYLK CL8.8 ZC
C	A0000277095	2	SPACER PLASTIC
D	A0000277097	1	ASSY CORD ELASTIC MOUNTS AND KEEPER
E	G057058	4	SCREW HHC M6-1.0 X 55 C8.8
F	A0000277086	1	STB BRACKET STORAGE DIFFUSED LENS

CONTROL BOX ASSEMBLY - ANALOG

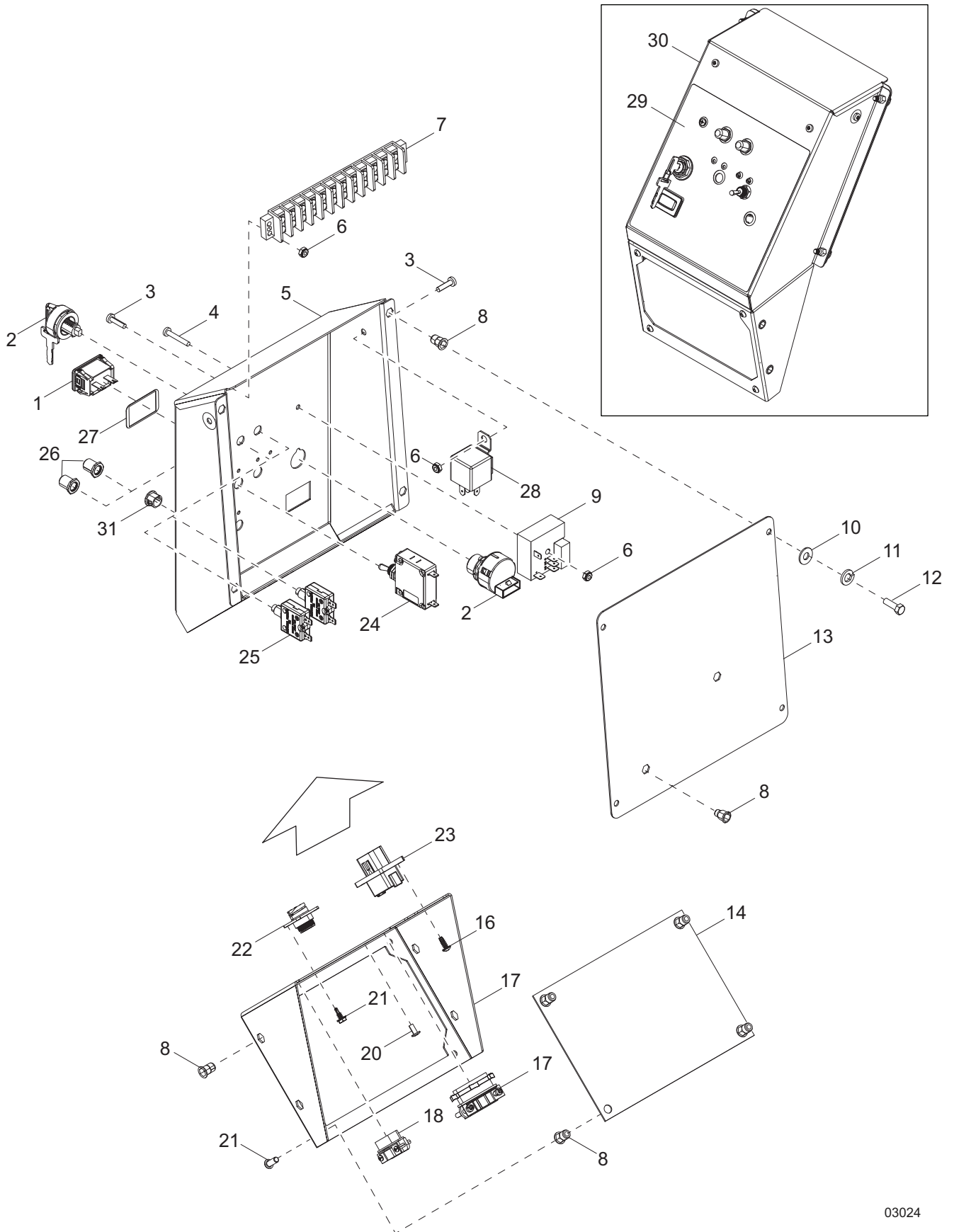

03024

CONTROL BOX ASSEMBLY - ANALOG

Item	Part No.	Qty	Description	Notes
1	36886	1	METER, HOUR	
2	36882	1	SWITCH, SEALED KEY - 4 POSITION	
3	60062	4	SCREW, 10-32 X .750 PAN PHILLIPS, G2	
4	63308	1	SCREW, 10-32 X 1.250 PAN PHILLIPS - SS	
5	A0000108466	1	BOX, CONTROL	
6	60061	5	NUT, 10-32 NYLOCK	
7	14139	1	TERMINAL BLOCK, 12 POSITION, 30A, 600V	
8	A0000181267	12	INSERT, M6 X 1.0 HEX NUT .7-4.2MM	
9	A0000216316	1	BREAKER, SLD 15A SINGLE POLE	
10	14201	1	RELAY, SPDT 10A 12VDC TIME DELAY-15 SEC.	
11	60243	4	WASHER, .250 FLAT .735/.060 - SS	
12	60286	4	WASHER, .250 SPLIT LOCK	
13	60335	4	SCREW, M6-1.00 X 25 STANDARD HEX - SS	
14	A0000141831	1	COVER, CONTROL BOX	
15	A0000141014	1	PANEL, NO RECEPTACLE	
16	37027	4	SCREW, 10-12 X .500 PAN PHILLIPS - PLASTITE	
17	A0000108467	1	BRACKET, RECEPTACLE MOUNTING	
18	66425	1	STRAIN RELIEF, 1.25 ROMEX W/NUT	
19	14219	1	STRAIN RELIEF, .750 ROMEX W/NUT	
20	60268	5	RIVET, .188 DIAMETER X .126 TO .250 GRIP - SS	
21	60364	4	SCREW, 10-16 X .500 STANDARD HEX, G2 - SELF DRILLING	
22	0A3359	4	SCREW, M6-1.0 X 16 STANDARD HEX - SS	
23	10000031026	1	CONNECTOR, PANEL MOUNT, 7 POSITION	
24	66695	1	CONNECTOR, DEUTSCH 12 POSITION RECEPT/ PIN - FLANGE	
25	36880	1	SWITCH, LIGHT 15A	
26	36935	2	BREAKER, 15A 250V SINGLE POLE	
27	36937	1	BREAKER, 10A DC	
28	36938	3	BOOT, PUSH BUTTON BREAKER	
29	65798	1	PLUG, HOLE .468 X .06 - BLACK	
30	A0000139089	1	ASSEMBLY, NO RECEPTACLE	ITEMS 8, AND 15
31	A0000073941	1	ASSEMBLY, CONTROL BOX	

CONTROL BOX ASSEMBLY - DIGITAL (IF EQUIPPED)

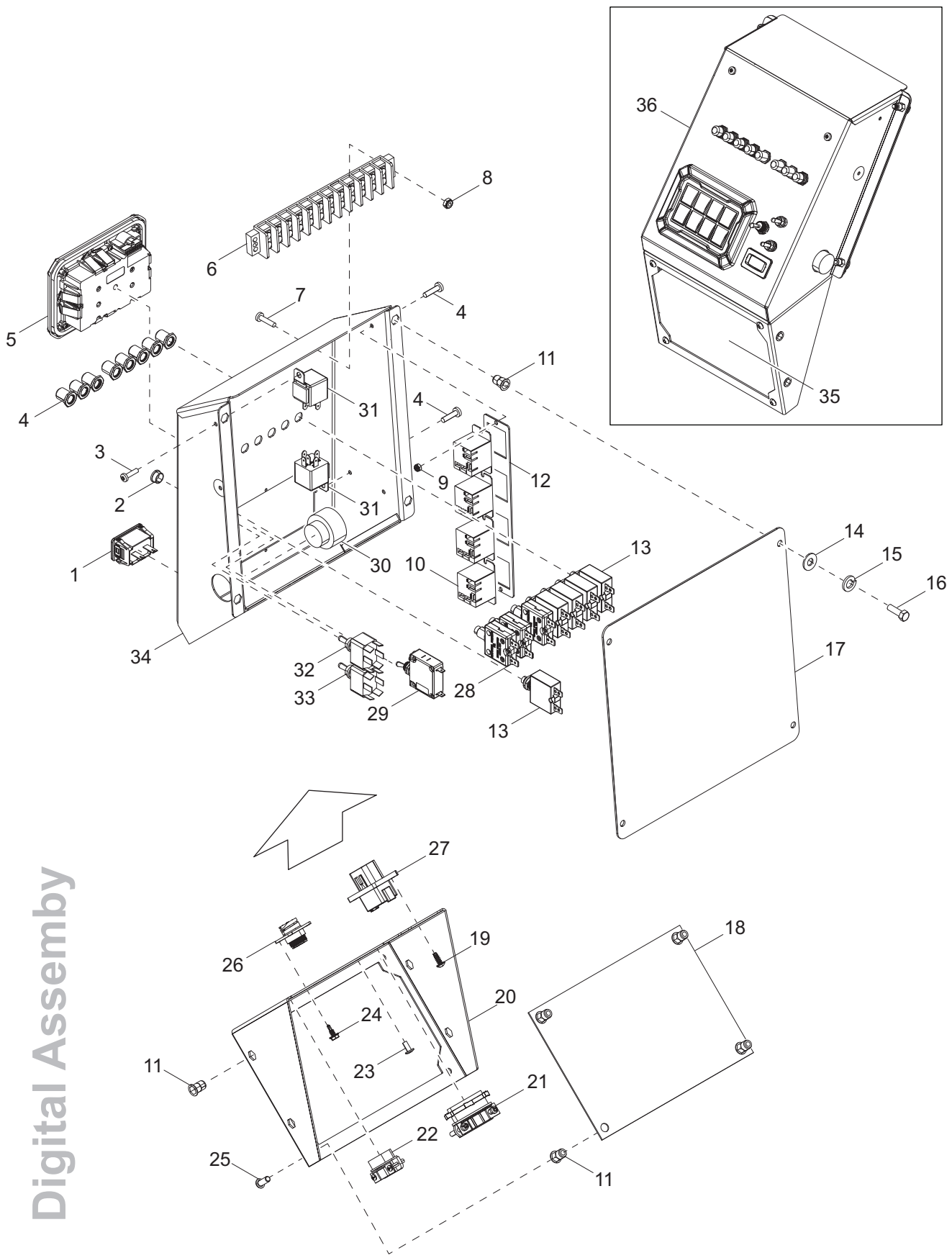

Digital Assembly

03025

CONTROL BOX ASSEMBLY - DIGITAL (IF EQUIPPED)

Item	Part No.	Qty	Description	Notes
1	36886	1	METER, HOUR	
2	65798	1	PLUG, HOLE .468 X .06 - BLACK	
3	62054	4	SCREW, 8-32 X .500 PAN PHILLIPS - SS	
4	36938	8	BOOT, PUSH BUTTON BREAKER	
5	A0000148033	1	CONTROLLER, DIGITAL	
6	14139	1	BLOCK, TERMINAL 12 POSITION 30A, 600V	
7	60062	2	SCREW, 10-32 X .750 PAN PHILLIPS, G2	
8	60061	2	NUT, 10-32 NYLOCK	
9	60270	4	NUT, 8-32 NYLOCK, G6	
10	29759	4	RELAY, 12V COIL 120-240 VAC RATED	
11	A0000181267	8	INSERT, M6 X 1.0 HEX NUT .7-4.2MM	
12	38447B	1	BRACKET, RELAY	
13	75030	5	BREAKER, 5A, 240V 1 POLE - PUSH BUTTON	
14	60243	4	WASHER, .250 FLAT .735/.060 - SS	
15	60286	4	WASHER, .250 SPLIT LOCK	
16	60335	4	SCREW, M6-1.00 X 25 STANDARD HEX - SS	
17	A0000141831	1	COVER, CONTROL BOX	
18	A0000141014	1	PANEL, NO RECEPTACLE	
19	37027	4	SCREW, 10-12 X .500 PAN PHILLIPS - PLASTITE	
20	A0000108467	1	BRACKET, RECEPTACLE MOUNTING	
21	66425	1	STRAIN RELIEF, 1.25 ROMEX W/NUT	
22	14219	1	STRAIN RELIEF, .750 ROMEX W/NUT	
23	60268	5	RIVET, .188 DIAMETER X .126 TO .250 GRIP - SS	
24	60364	4	SCREW, 10-16 X .500 STANDARD HEX, G2 - SELF DRILLING	
25	0A3359	4	SCREW, M6-1.0 X 16 STANDARD HEX - SS	
26	10000031026	1	CONNECTOR, PANEL MOUNT, 7 POSITION	
27	66695	1	CONNECTOR, DEUTSCH 12 POSITION RECEPT/ PIN - FLANGE	
28	36937	3	BREAKER, 10A DC	
29	A0000216316	1	BREAKER, SLD 15A SINGLE POLE	
30	73217	1	HORN, ALARM 6-28V DC	
31	65049	2	RELAY, 12V 30/40 N.O. W/DIODE	
32	68508	1	SWITCH, TOGGLE SPST (ON-OFF) 12A 125V	
33	10000031493	1	SWITCH, TOGGLE SPDT SPRING - WEATHER-PROOF	WITH ELECTRIC WINCH
34	A0000222093	1	CONTROL BOX, DIGITAL	
35	A0000139089	1	ASSEMBLY, NO RECEPTACLE	ITEMS 11 AND 18
36	A0000163330	1	ASSEMBLY, CONTROL BOX - DIGITAL	

ANALOG CONTROL BOX ASSEMBLY WITH SHORE POWER (IF EQUIPPED)

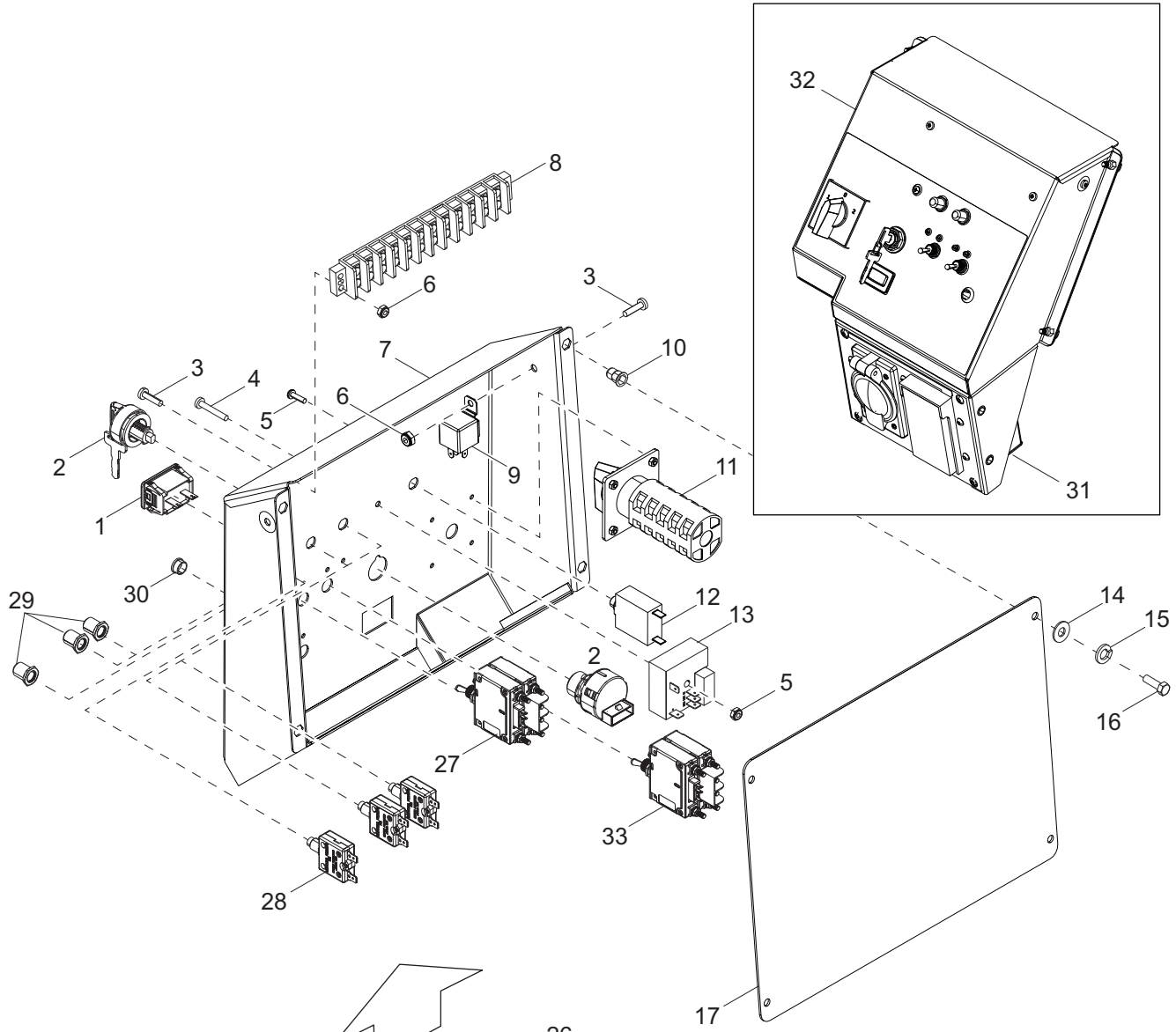

Analog Assembly
 Shore Power

03026

ANALOG CONTROL BOX ASSEMBLY WITH SHORE POWER (IF EQUIPPED)

Item	Part No.	Qty	Description	Notes
1	36886	1	METER, HOUR	
2	36882	1	SWITCH, SEALED KEY - 4 POSITION	
3	60062	4	SCREW, 10-32 X .750 PAN PHILLIPS, G2	
4	63308	1	SCREW, 10-32 X 1.250 PAN PHILLIPS - SS	
5	62210	4	SCREW, 6-32 X .500 PAN PHILLIPS - SS	
6	60061	5	NUT, 10-32 NYLOCK	
7	A0000379693	1	BOX, CONTROL	
8	14139	1	TERMINAL BLOCK, 12 POSITION, 30A, 600V	
9	65049	1	RELAY, 12V 30/40A N.O. W/DIODE	
10	A0000181267	12	INSERT, M6 X 1.0 HEX NUT .7-4.2MM	
11	A0000419428	1	SWITCH, ROTARY 600V 20A, 3 POSITION	
12	65849	1	BREAKER, 20A, 120V 1 POLE - PUSH BUTTON	
13	14201	1	RELAY, SPDT 10A 12VDC TIME DELAY-15 SEC.	
14	60243	4	WASHER, .250 FLAT .735/.060 - SS	
15	60286	4	WASHER, .250 SPLIT LOCK	
16	60335	4	SCREW, M6-1.00 X 25 STANDARD HEX - SS	
17	A0000380884	1	COVER, CONTROL BOX	
18	37027	4	SCREW, 10-12 X .500 PAN PHILLIPS - PLASTITE	
19	A0000108467	1	BRACKET, RECEPTACLE MOUNTING	
20	66425	1	STRAIN RELIEF, 1.25 ROMEX W/NUT	
21	14219	1	STRAIN RELIEF, .750 ROMEX W/NUT	
22	60268	5	RIVET, .188 DIAMETER X .126 TO .250 GRIP - SS	
23	60364	4	SCREW, 10-16 X .500 STANDARD HEX, G2 - SELF DRILLING	
24	0A3359	4	SCREW, M6-1.0 X 16 STANDARD HEX - SS	
25	10000031026	1	CONNECTOR, PANEL MOUNT, 7 POSITION	
26	66695	1	CONNECTOR, DEUTSCH 12 POSITION RECEPT/ PIN - FLANGE	
27	A0000310568	1	BREAKER, SLD 20A, 2 POLE	W/A0000356800
28	36935	3	BREAKER, 15A 250V SINGLE POLE	
29	36938	4	BOOT, PUSH BUTTON BREAKER	
30	65798	1	PLUG, HOLE .468 X .06 - BLACK	
31	A0000356800	1	ASSEMBLY, INLET RECEPTACLE W/ 120V 20A BREAKER	SEE PAGES 34-35
32	A0000379845	1	ASSEMBLY, CONTROL BOX - ANALOG - SHORE POWER	

DIGITAL CONTROL BOX ASSEMBLY WITH SHORE POWER (IF EQUIPPED)

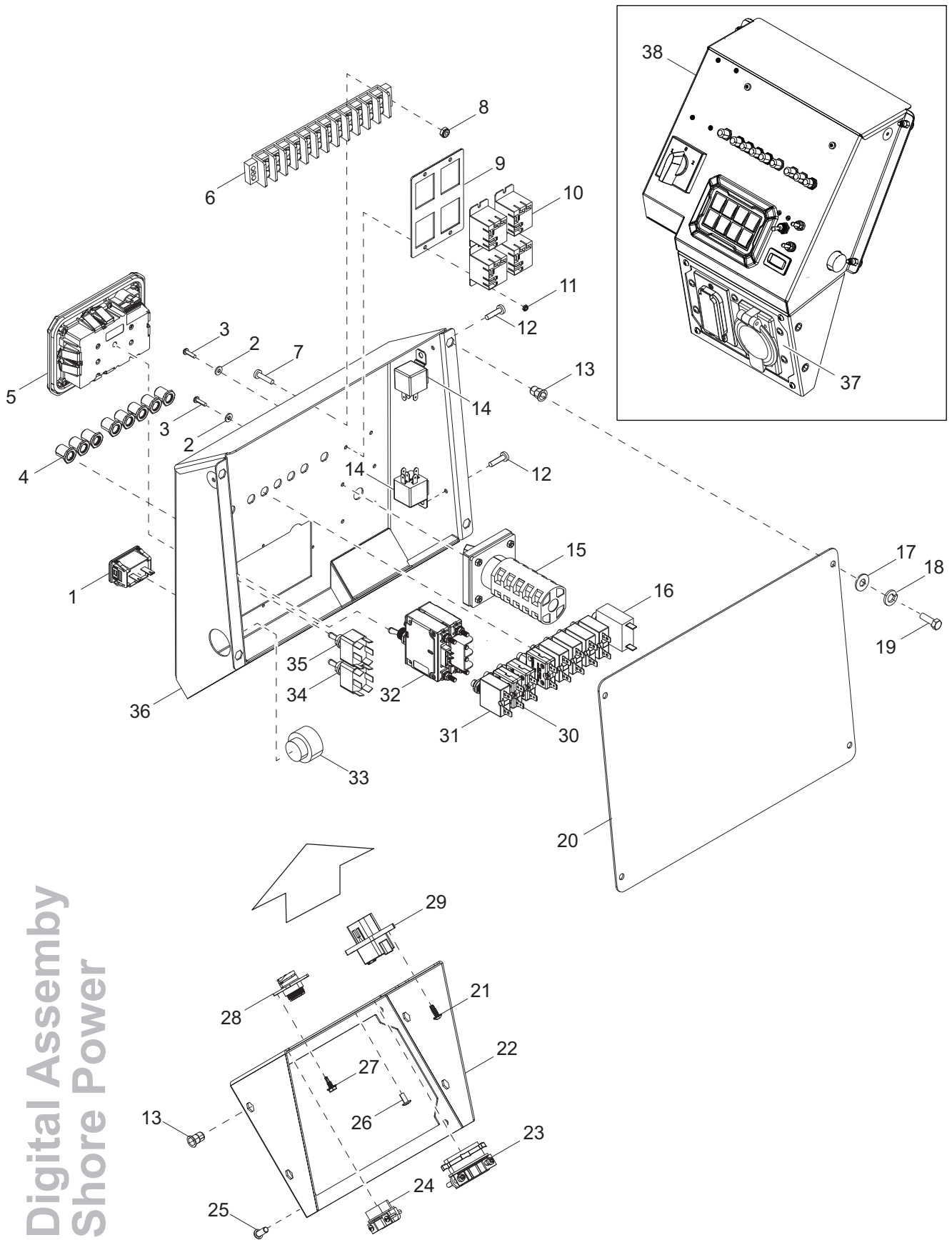

Digital Assembly
Shore Power

03027

DIGITAL CONTROL BOX ASSEMBLY WITH SHORE POWER (IF EQUIPPED)

Item	Part No.	Qty	Description	Notes
1	36886	1	Meter, hour	
2	60289	8	WASHER, #6 FLAT	
3	62210	8	SCREW, 6-32 X .500 PAN PHILLIPS - SS	
4	36938	9	BOOT, PUSH BUTTON BREAKER	
5	A0000148033	1	CONTROLLER, DIGITAL	
6	14139	1	BLOCK, TERMINAL 12 POSITION 30A, 600V	
7	60061	2	NUT, 10-32 NYLOCK	
8	60062	2	SCREW, 10-32 X .750 PAN PHILLIPS, G2	
9	A0000382880	1	BRACKET, RELAY MOUNT	
10	29759	4	RELAY, 12V COIL 120-240 VAC RATED	
11	60728	8	NUT, 6-32 NYLOCK, G%	
12	62054	4	SCREW, 8-32 X .500 PAN PHILLIPS - SS	
13	A0000181267	8	INSERT, M6 X 1.0 HEX NUT .7-4.2MM	
14	65049	2	RELAY, 12V 30/40 N.O. W/DIODE	
15	A0000419428	1	SWITCH, ROTARY 600V 20A 3 POSITION	
16	65849	1	BREAKER, 20A 120V 1 POLE - PUSH BUTTON	
17	60243	4	WASHER, .250 FLAT .735/.060 - SS	
18	60286	4	WASHER, .250 SPLIT LOCK	
19	60335	4	SCREW, M6-1.00 X 25 STANDARD HEX - SS	
20	A0000380884	1	COVER, CONTROL BOX	
21	37027	4	SCREW, 10-12 X .500 PAN PHILLIPS	
22	A0000108467	1	BRACKET, RECEPTACLE MOUNTING	
23	66425	1	STRAIN RELIEF, 1.25 W/NUT	
24	14219	1	STRAIN RELIEF, .750 W/NUT	
25	0A3359	4	SCREW, M6-1.0 X 16 STANDARD HEX - SS	
26	60268	5	RIVET, .188 DIAMETER X .126 TO .250 GRIP - SS	
27	60364	4	SCREW, 10-16 X .500 STANDARD HEX, G2 - SELF DRILLING	
28	10000031026	1	CONNECTOR, PANEL MOUNT, 7 POSITION	
29	66695	1	CONNECTOR, DEUTSCH 12 POSITION RECEPT/ PIN - FLANGE	
30	36935	3	BREAKER, 15A 250V 1 POLE - MECHANICAL	
31	75030	5	BREAKER, 5A, 240V 1 POLE - PUSH BUTTON	
32	A0000310568	1	BREAKER, SLD 20A 2 POLE	W/A0000356800
33	73217	1	HORN, ALARM 6-28V DC	
34	65707	1	SWITCH, TOGGLE SPDT SPRING - WEATHER-PROOF	
35	68508	1	SWITCH, TOGGLE SPST (ON-OFF) 12A 125V	
36	A0000380933	1	CONTROL BOX, DIGITAL	
37	A0000356800	1	ASSEMBLY, INLET RECEPTACLE W/ 120V 20A BREAKER	
38	A0000380924	1	ASSEMBLY, CONTROL BOX - DIGITAL- SHORE POWER	

CONTROL BOX SHORE POWER PANEL (IF EQUIPPED)

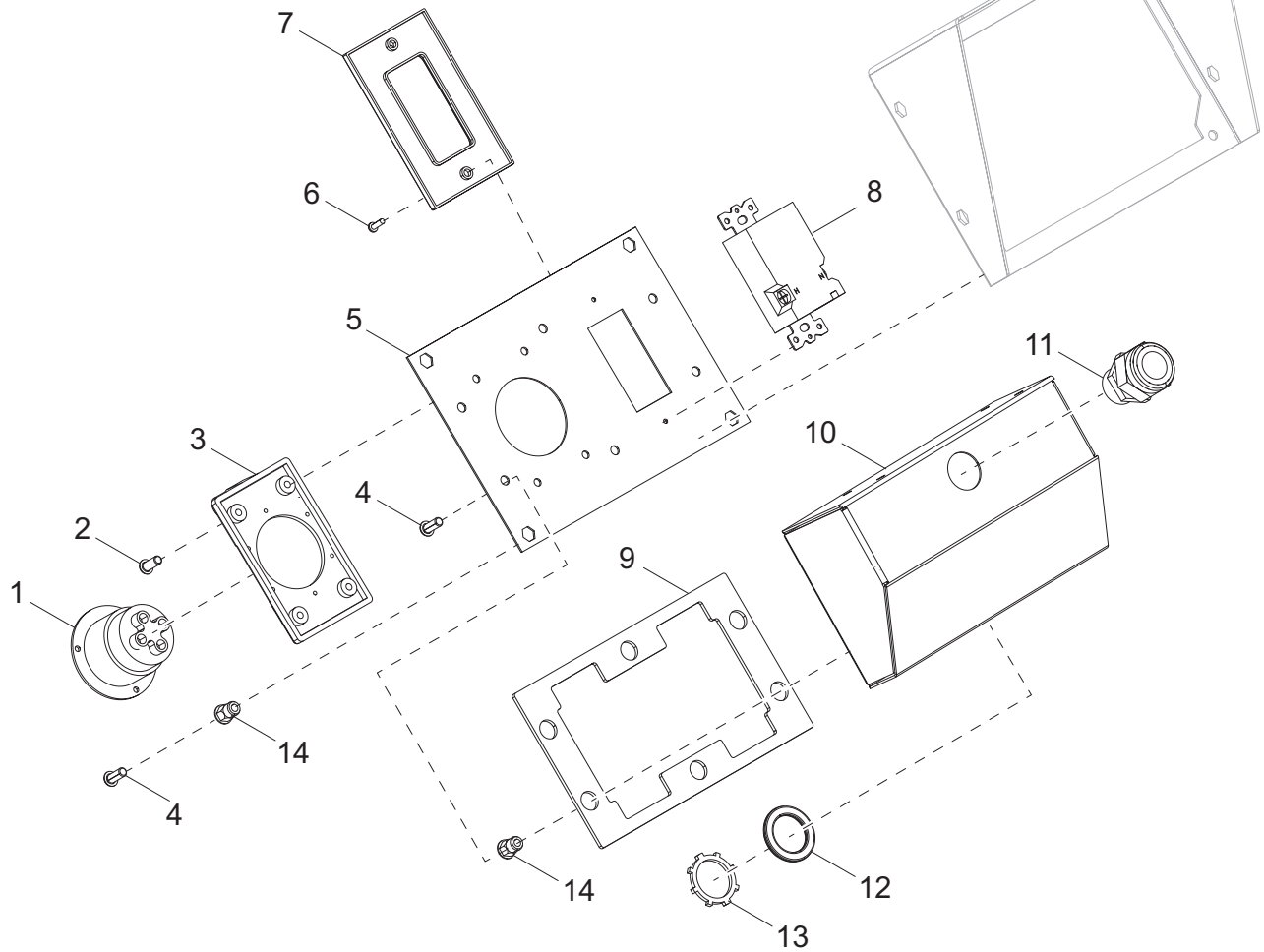
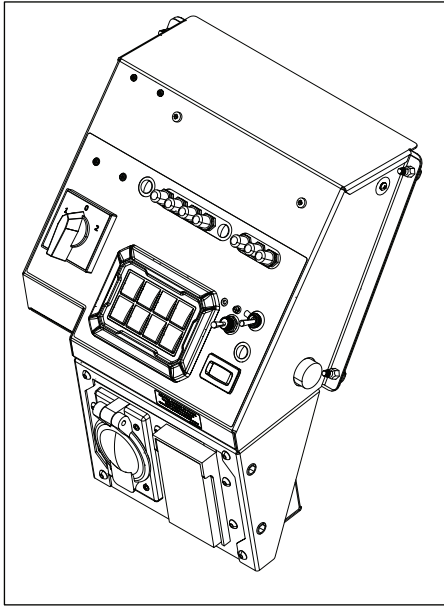

03028

CONTROL BOX SHORE POWER PANEL (IF EQUIPPED)

Item	Part No.	Qty	Description	Notes
1	A0000391270	1	RECEPTACLE, 120/250V 20A INLET	INC HARDWARE
2	60046	4	SCREW, 6-32 X .750 PAN PHILLIPS, G2	
3	65520	1	COVER, RECEPTACLE 50A - WEATHERPROOF	
4	0A3359	10	SCREW, M6-1.0 X 16 BTN HEAD SECURITY - SS	
5	A0000356915	1	PLATE, RECEPTACLE MOUNT 120V W/BREAKER	
6	62210	2	SCREW, 6-32 X .50 PAN PHILLIPS - SS	
7	37017	1	COVER, RECEPTACLE 20A GFI - WEATHER- PROOF	
8	14130	1	RECEPTACLE, 120V/20A GFI	
9	A0000415963	1	GASKET, RECEPTACLE BOX	
10	A0000415820	1	BOX, RECEPTACLE	
11	14656	1	STRAIN RELIEF, .750NPT .545/.709 ID	
12	15698	1	WASHER, .750 SEALING - RUBBER	
13	16300	1	NUT, SPECIAL .750 NPT - LOCK	
14	A0000181267	10	NUT, M6 X 1.0 HEX INSERT	
15	A0000356800	1	ASSEMBLY, INLET RECEPTACLE W/120V 20A BREAKER	
--	A0000310568	1	BREAKER, SLD 20A 2 POLE - PANEL MOUNT	

CONTROL BOX RECEPTACLE PANEL (IF EQUIPPED)

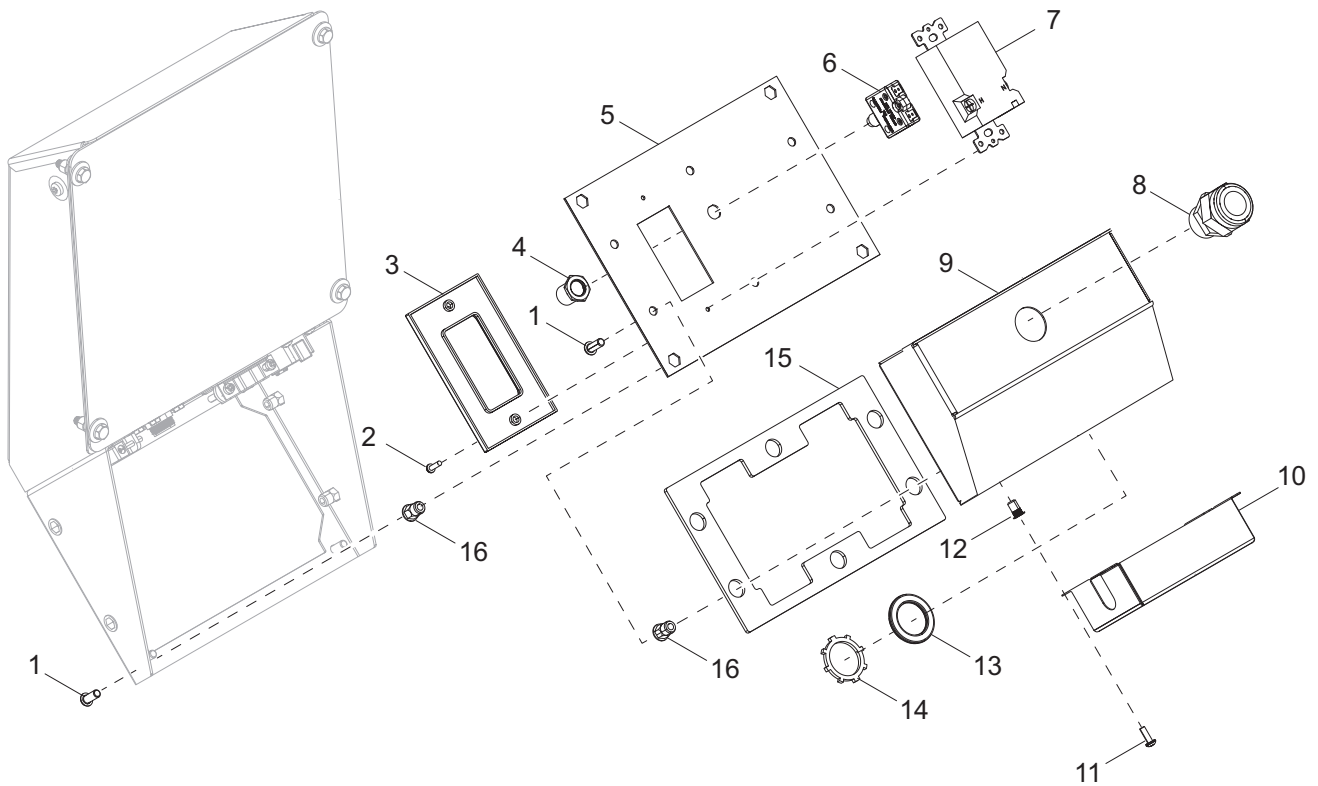
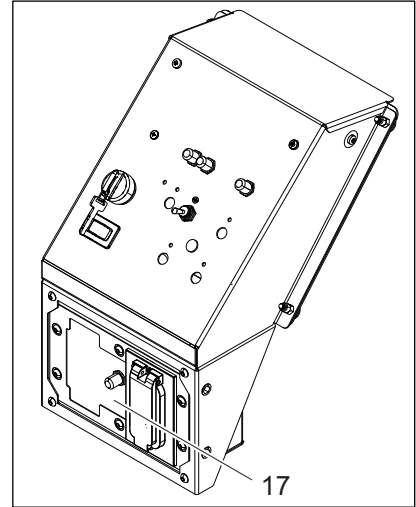

03029

CONTROL BOX RECEPTACLE PANEL (IF EQUIPPED)

Item	Part No.	Qty	Description	Notes
1	0A3359	8	SCREW, M6-1.0 X 16 STANDARD HEX - SS	
2	62210	2	SCREW, 6-32 X .50 PAN PHILLIPS - SS	
3	37017	1	COVER, RECEPTACLE - WEATHER PROOF	
4	36938	1	BOOT, PUSH BUTTON BREAKER	
5	A0000139161	1	PLATE, RECEPTACLE MOUNT	
6	36937	1	BREAKER, 10A DC	
7	14130	1	RECEPTACLE 120V/20A GFII	
8	14656	1	STRAIN RELIEF, .750NPT .545/.709 ID - WATER TIGHT	
9	A0000072105	1	BOX, RECEPTACLE	
10	A0000393922	1	BRACKET, BATTERY CHARGER COVER	
11	60526	4	SCREW, 8-32 X .500 PAN PHILLIPS, G2	
12	A0000087390	4	INSERT, RIBBED 8-32 - .130 FRIP - CLOSED	
13	15698	1	WASHER, .750NPT - SEALING - RUBBER	
14	16300	1	NUT, .750 NPT LOCK	
15	A0000142340	1	GASKET, RECEPTACLE BOX	
16	A0000181267	8	INSERT, M6 X 1.0 HEX NUT .7-4.2MM	
17	A0000139331	1	ASSEMBLY, RECEPTACLE 120V 10A	

COOLING SYSTEM ASSEMBLY

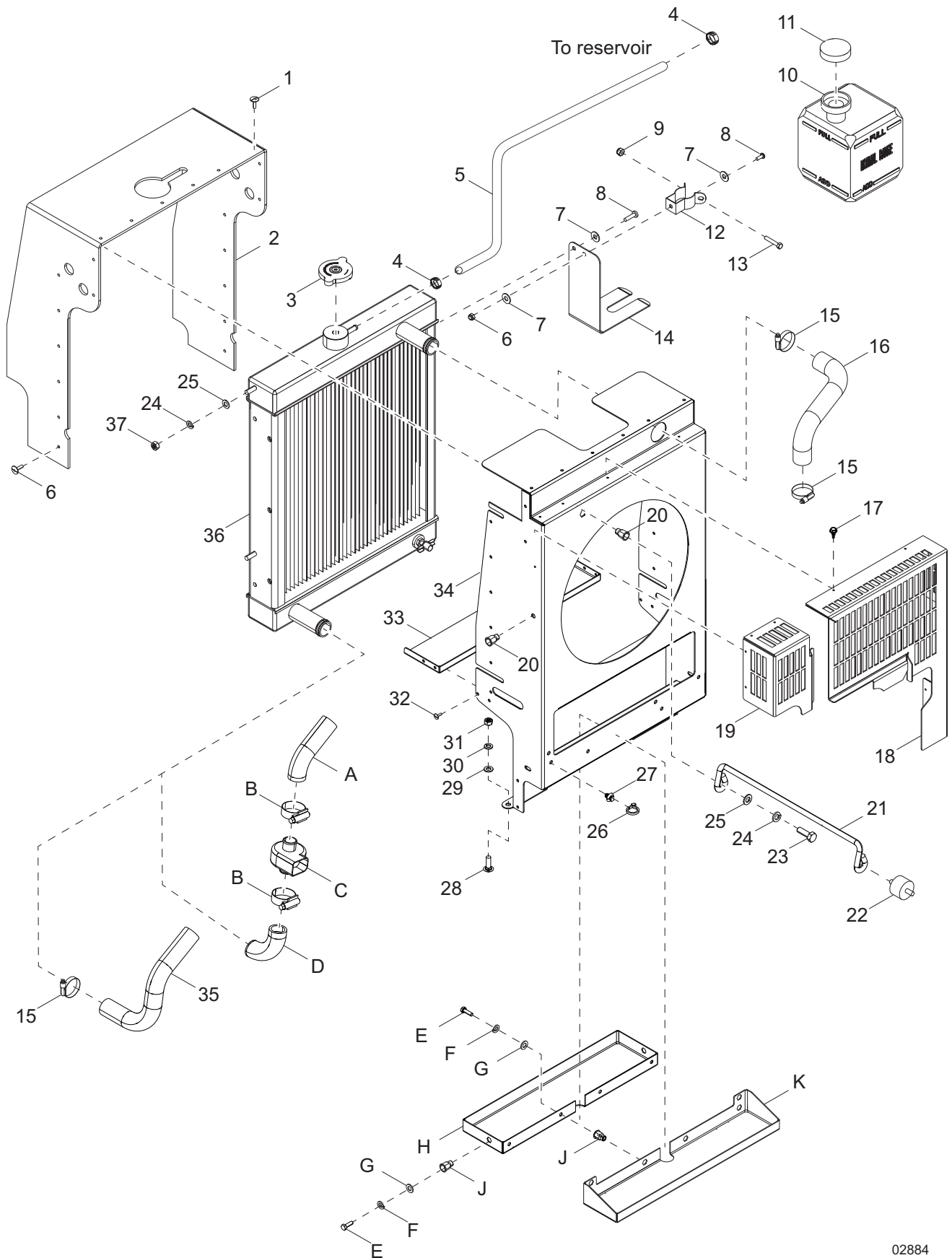

02884

COOLING SYSTEM ASSEMBLY

Item	Part No.	Qty	Description	Notes
1	60195	21	RIVET, .188 X .375 TO .500 GRIP	
2	A0000077707	1	SEAL, COOLING - RUBBER	
3	19219	1	CAP, RADIATOR	
4	60777	2	CLAMP, HOSE .312 FUEL - CRIMP STYLE	
5	50018	3.0 ft	HOSE, FUEL .312ID 50PSI SAE 30R7	
6	60061	2	NUT, 10-32 NYLOCK	
7	60067	4	WASHER, #10 FLAT .435/.060 - SS	
8	61180	2	SCREW, 10-32 X .750 PAN PHILLIPS - SS	
9	60144	1	NUT, .250-20 NYLOCK, G5	
10	20287	1	JUG, OVERFLOW	
11	19714	1	CAP, OVERFLOW BOTTLE	
12	19726	1	CLAMP, OVERFLOW BOTTLE	
13	60414	1	SCREW, .250-20 X 1.50 STANDARD HEX, G5	
14	22419B	1	BRACKET, OVER FLOW JUG SUPPORT	
15	15422	4	CLAMP, HOSE SAE 020 (.75-1.75)	
16	10000047702	1	HOSE, UPPER RADIATOR	
17	60364	13	SCREW, 10-16 X .500 STANDARD HEX, G2	
18	A0000083514	1	GUARD, FAN RH	
19	A0000083519	1	GUARD, FAN LH	
20	OH5513	2	NUT, M8 X 1.25 LOCK	
21	A0000301146	1	ROD, RADIATOR STAY	
22	34052	1	ISOLATOR	
23	60049	2	SCREW, M8-1.25 X 25 STANDARD HEX, G8.8	
24	60029	5	WASHER, M5 SPLIT LOCK	
25	60166	7	WASHER, M8 FLAT	
26	15630	2	CABLE TIE, 6.13 X .141 - BLACK	
27	66685	2	MOUNT, CABLE TIE .250 -280 DIAMETER .031 - .270 GRIP	
28	61066	4	SCREW, .312-18 X 1.00 CARRIAGE BOLT	
29	60166	4	WASHER, M8 FLAT	
30	60271	4	WASHER, .312 SPLIT LOCK	
31	60285	4	NUT, .312-18 HEX, G2	
32	60268	8	RIVET, .188 X .126 TO .250 GRIP - SS	
33	A0000080671	1	BLOCK-OFF, RADIATOR	
34	A0000300030	1	UPRIGHT, RADIATOR	
35	10000047331	1	HOSE, RADIATOR - LOWER	
36	10000020162	1	RADIATOR	
37	60032	5	NUT, M8-1.25 HEX, G8.8	

Engine Heater (If equipped):

A	A0000149876	1	HOSE, LOWER RADIATOR
B	15422	4	CLAMP, HOSE SAE 020 (.75-1.75)
C	65649	1	HEATER, ENGINE
D	A00000149869	1	HOSE, LOWER RADIATOR

Containment (If equipped):

E	042568	6	SCREW, M6-1.0 X 20 HHC, G8.8
F	38522	6	WASHER, M6-.250 SPLIT LOCK
G	049811	2	WASHER, M6 FLAT
H	10000047855	1	CONTAINMENT, FRONT
J	092120	8	INSERT,
K	10000047759	1	CONTAINMENT, REAR

ENGINE ASSEMBLY (1 OF 2)

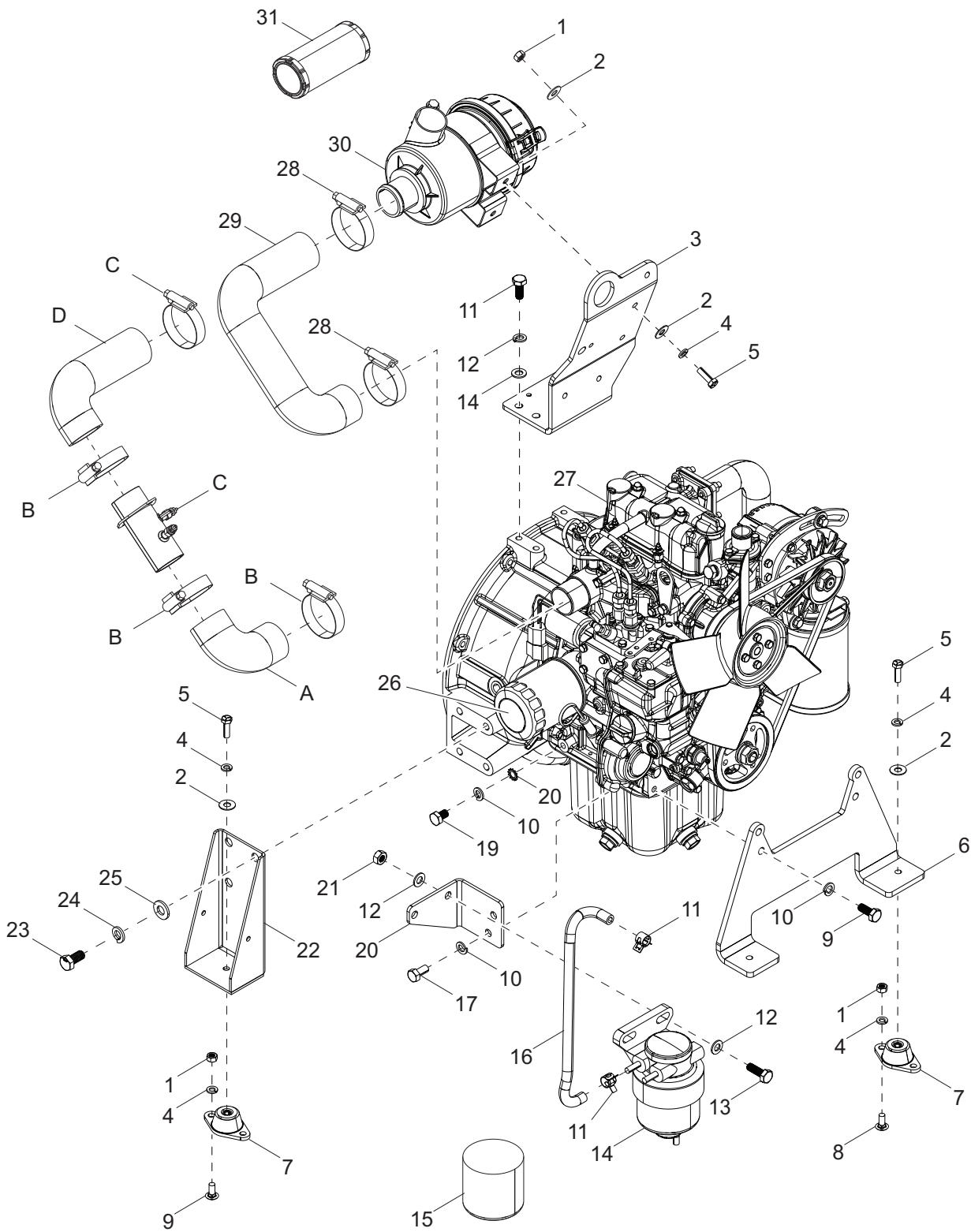

02885

ENGINE ASSEMBLY (1 OF 2)

Item	Part No.	Qty	Description	Notes
1	60285	10	NUT, .312-18 HEX, G2	
2	60119	12	WASHER, .312 FLAT .875/.07	
3	A0000244499	1	BRACKET, AIR CLEANER	
4	60271	18	WASHER, .312 SPLIT LOCK	
5	60028	6	SCREW, .312-18 X 1.00 STANDARD HEX, G5	
6	10000047388	1	MOUNT, ENGINE	
7	10000047263	4	ISOLATOR, COMPRESSION - 70#	
8	61214	4	SCREW, .312-18 X .750 CARRIAGE SQUARE - SS	
9	60422	8	SCREW, M10-1.25 X 25 STANDARD HEX, G8.8	
10	60026	10	WASHER, M10 SPLIT LOCK	
11	10000045619	2	CLAMP, HOSE CONSTANT TENSION	
12	60027	8	WASHER, M10 FLAT	
13	60494	2	SCREW, M10-1.25 X 30 STANDARD HEX, G8.8	
14	10000022110	1	FILTER, FUEL - HEAD AND ELEMENT	INCL. 10000023037
15	10000023037	1	FILTER, FUEL - ELEMENT	
16	50018	1.75 ft	HOSE, FUEL .312 ID 50 PSI SAE 30R7	
17	62159	2	SCREW, M10-1.25 X 20 STANDARD HEX, G8.8	
18	10000047425	1	MOUNT, FUEL FILTER	
19	60495	2	SCREW, M10-1.25 X 16 STANDARD HEX, G8.8	
20	60747	2	WASHER, .375 INTERNAL STAR	
21	60344	2	NUT, M10-1.25 HEX - SS	
22	10000047397	2	MOUNT, ENGINE - REAR	
23	61087	8	SCREW, M12-1.25 X 25 STANDARD HEX, G10.9	
24	60276	8	WASHER, .500 SPLIT LOCK	
25	60699	8	WASHER, .500 FLAT 1.070/.080 - SS	
26	70124	1	FILTER, OIL 750 HR.	750 HR INTERVAL
27	10000037471	1	ENGINE, L2E T4F	
28	60316	4	CLAMP, HOSE SAE 032 (1.56-2.50)	
29	10000044508	1	HOSE, AIR CLEANER	
30	10000021718	1	FILTER, AIR W/BRACKET	INCL. 16444
31	16444	1	ELEMENT, AIR FILTER	

Intake Heater (If equipped):

A	A0000149900	1	HOSE, AIR CLEANER
B	60316	4	CLAMP, HOSE SAE 032 (1.56-2.50)
C	A0000149884	1	ASSEMBLY, INTAKE HEATER
D	A0000149897	1	HOSE, AIR CLEANER

Note: Engine parts used in all Generac Mobile Products, LLC equipment carry the Original Equipment Manufacturer (OEM) warranty unless otherwise stated. OEM warranty parts must be purchased through an OEM dealer. Please contact Generac Mobile Products, LLC with questions

ENGINE ASSEMBLY (2 OF 2)

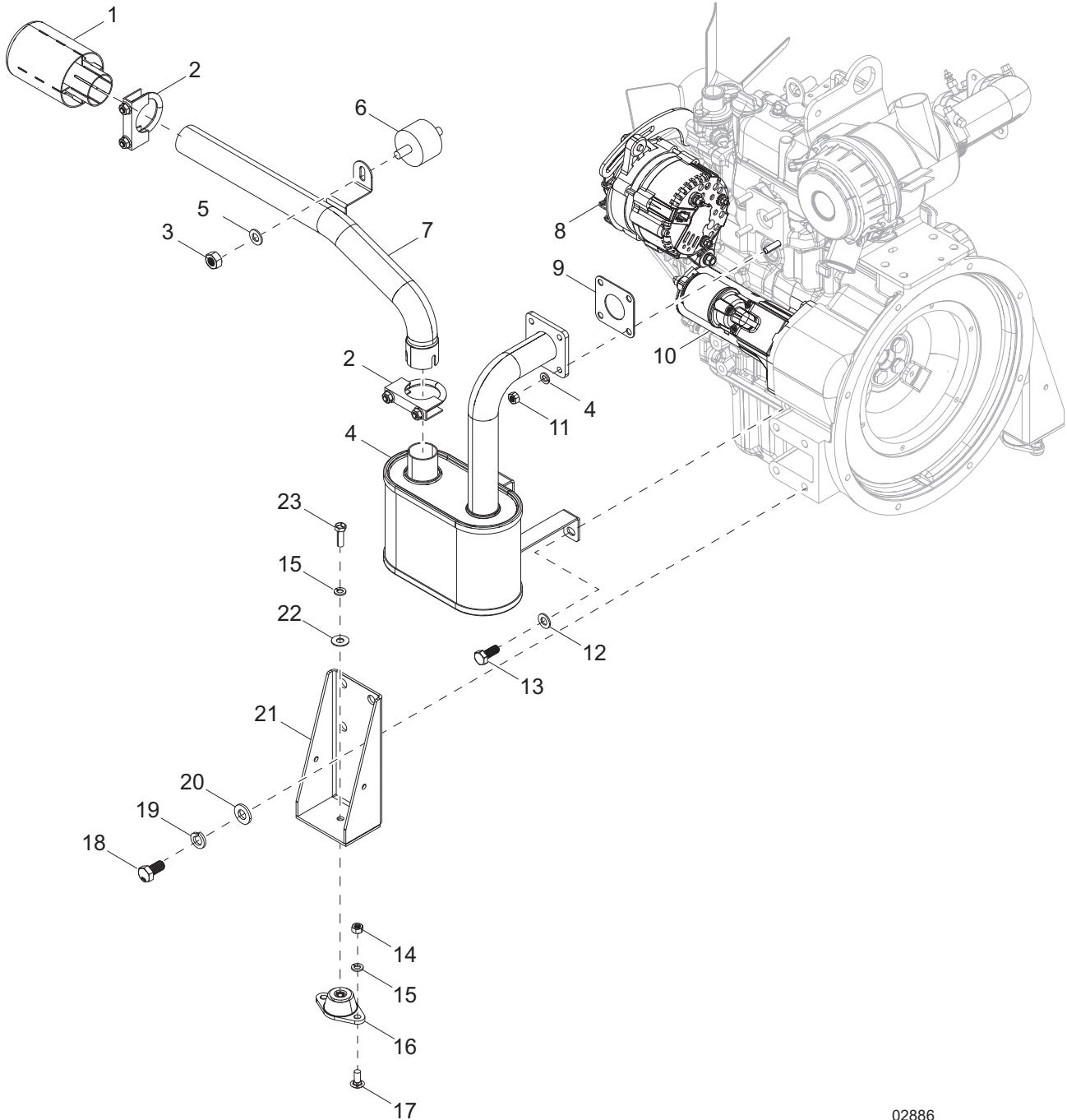

02886

ENGINE ASSEMBLY (2 OF 2)

Item	Part No.	Qty	Description	Notes
1	10000021954	1	TIP, EXHAUST	
2	68082	2	CLAMP, MUFFLER 1.63	
3	62079	1	NUT, .312-18 NYLOCK	
4	10000047042	1	WELDMENT, MUFFLER	
5	60119	1	WASHER, .312 FLAT	
6	34052	1	ISOLATER	
7	A0000284243	1	WELDMENT, SIDE EXHAUST	
8	A0000083440	1	ALTERNATOR	
9	11042SRV	1	GASKET, MUFFLER	
10	70232	1	STARTER	
11	60032	5	NUT, M8-1.25 HEX HEAD, G8.8	
12	60027	2	WASHER, M10 FLAT	
13	60422	2	SCREW, M10-1.25 X 25 STANDARD HEX, G8.8	
14	60285	2	NUT, .312-18 HEX, G2	
15	60271	1	WASHER, .312 SPLIT LOCK	
16	10000047263	1	ISOLATOR, COMPRESSION - NEOPRENE	
17	61214	2	SCREW, .312-18 X .750 CARRIAGE BOLT	
18	61087	4	SCREW, M12 -1.25 X 25 STANDARD HEX, G10,9	
19	60276	4	WASHER, .500 SPLIT LOCK	
20	60699	4	WASHER, .500 FLAT 1.070/.080 - SS	
21	10000047397	1	MOUNT, ENGINE - REAR	
22	60119	1	WASHER, .312 FLAT .875/.070	
23	60028	1	SCREW, .312-18 X 1.00 STANDARD HEX, G5	

Note: Engine parts used in all Generac Mobile Products, LLC equipment carry the Original Equipment Manufacturer (OEM) warranty unless otherwise stated. OEM warranty parts must be purchased through an OEM dealer. Please contact Generac Mobile Products, LLC with questions

ENGINE AND GENERATOR TO UNIT

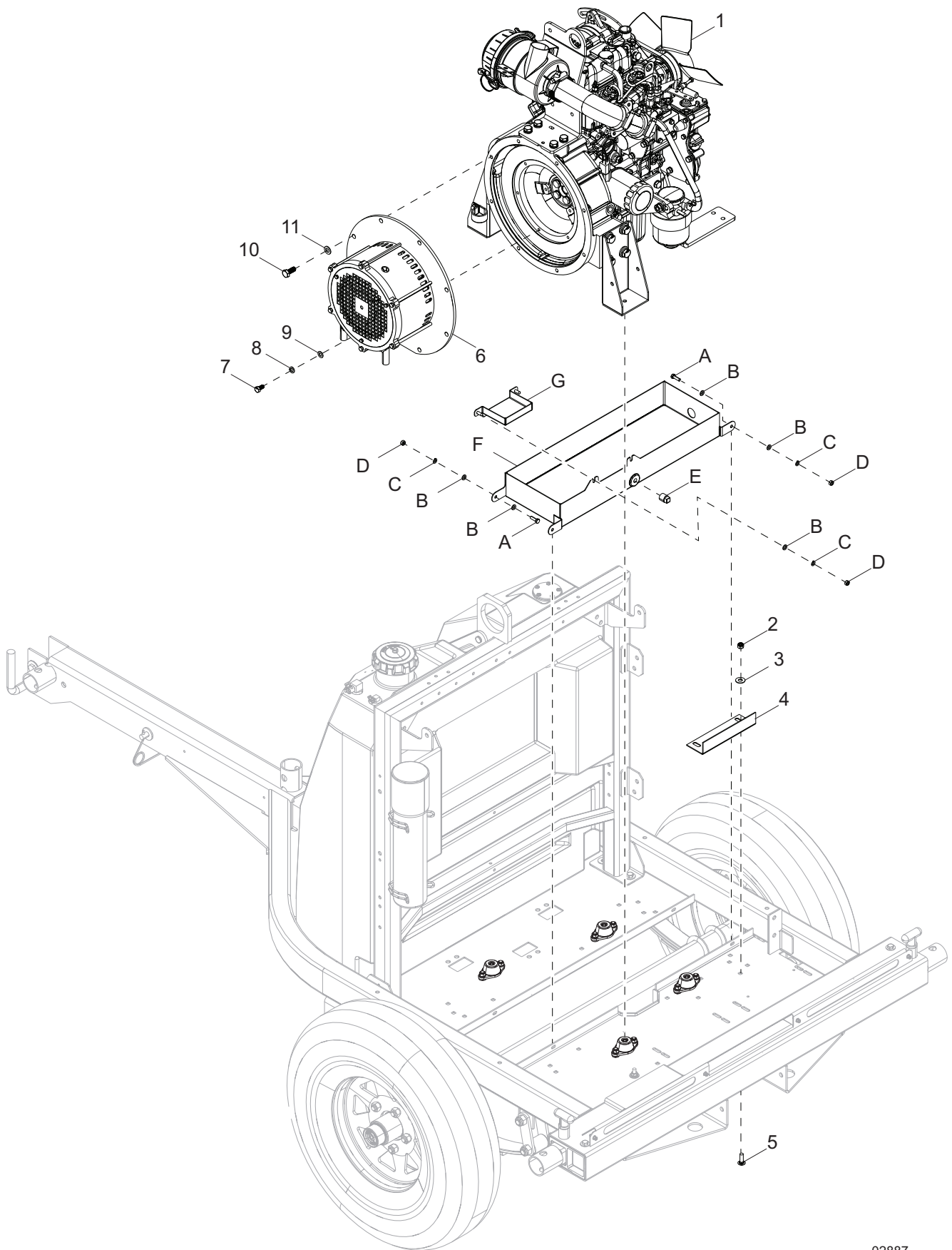

02887

ENGINE AND GENERATOR TO UNIT

Item	Part No.	Qty	Description	Notes
1	10000037471	1	ENGINE, MITSUBISHI L2E T4F	
2	60303	2	NUT, .312-18 NYLOCK, G2	
3	60119	2	WASHER, .312 FLAT .875/.070	
4	A0000121603	1	BRACKET, BATTERY STOP	
5	61066	2	SCREW, .312-18 X 1.00 CARRIAGE SQUARE - SS	
6	10000044412	1	GENERATOR, MARATHON 1.4KW 60HZ	
7	60165	6	SCREW, M8-1.25 X 16 STANDARD HEX, G10.9	
8	60029	6	WASHER, M8 SPLIT LOCK	
9	60166	6	WASHER, M8 FLAT	
10	60422	8	SCREW, M10-1.25 X 25 STANDARD HEX, G8.8	
11	60027	8	WASHER, M10 FLAT	
--	A0000215058	1	HARNESS, CONTROL TO ALTERNATOR	
--	11923	1	WIRE GROUP, 3000 ENGINE	

Containment (If equipped):

A	042568	4	SCREW, M6
B	049811	8	WASHER, M6 FLAT
C	38522	4	WASHER, M6-.250 LOCK
D	049813	4	NUT, M6-1.0, G8
E	026925	1	PLUG, STANDARD PIPE, .375 SQUARE HEAD
F	10000047071	1	WELDMENT, CONTAINMENT PAN BODY
G	10000047035	1	OIL CATCH, CONTAINMENT PAN

Note: Generator parts used in all Generac Mobile Products, LLC equipment carry the Original Equipment Manufacturer (OEM) warranty unless otherwise stated. OEM warranty parts must be purchased through an OEM dealer. Please contact Generac Mobile Products, LLC with questions.

GENERATOR

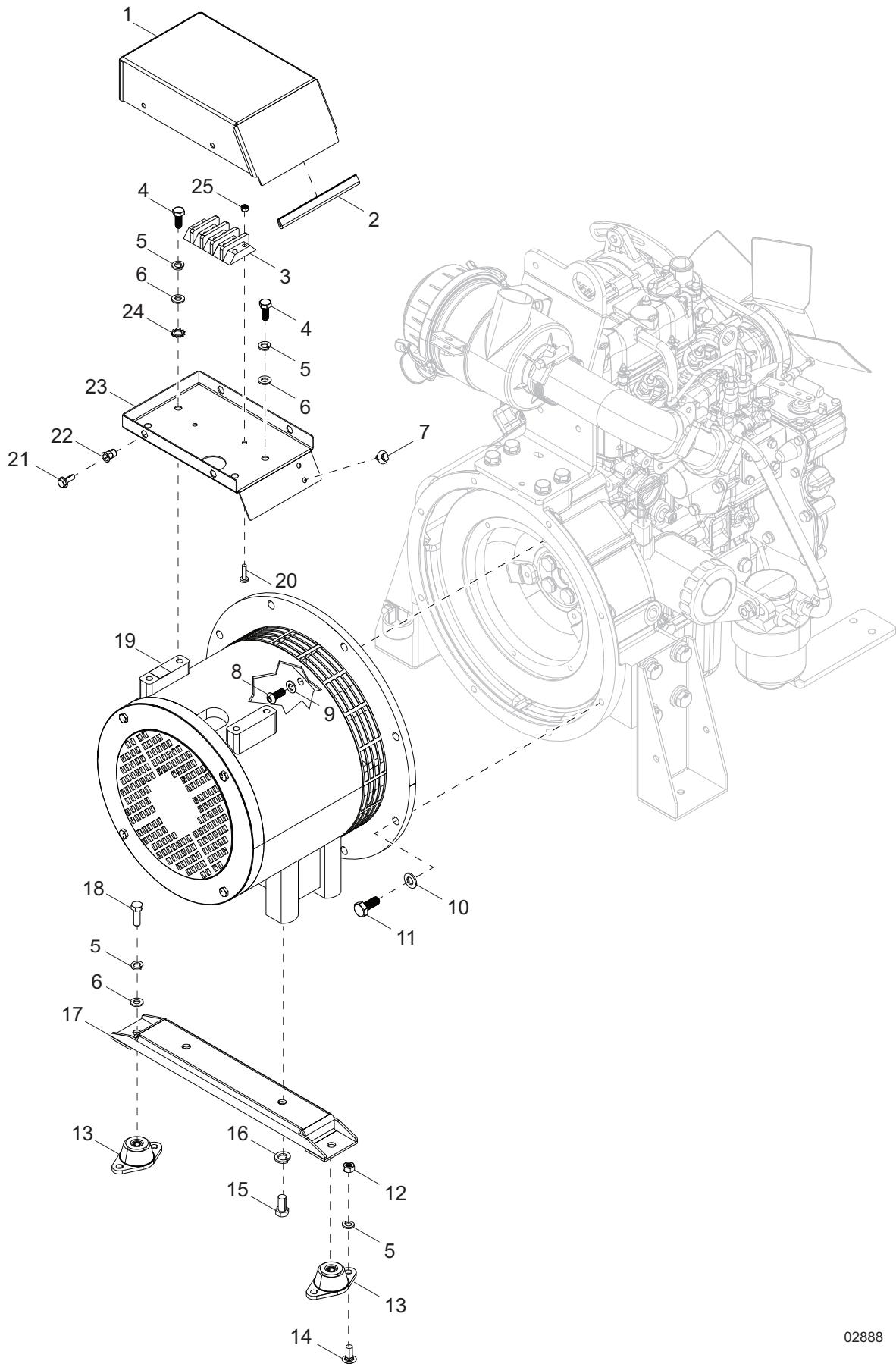

02888

GENERATOR

Item	Part No.	Qty	Description	Notes
1	A0000136600	1	Cover, alternator junction box	
2	19351	.42 ft	Seal, U-channel	
3	66694	1	Block, terminal 3-position	
4	61082	4	Screw, M8-1.25 x 20 standard hex	
5	60029	10	Washer, M8 split lock	
6	60031	6	Washer, M8 flat	
7	66685	2	Mount, cable tie .25-.28 diameter .031-.27 grip	
8	72162	6	Screw, M8-1.25 x 20 button hex, G10.9	
9	60166	6	Washer, M8 flat	
10	60422	8	Screw, M10-1.25 x 25 standard hex, G8.8	
11	60027	8	Washer, M10 flat	
12	60412	4	Nut, .312-18 hex, G5	
13	10000047263	2	Isolator, compression 70#	
14	61214	4	Screw, .312-18 x .750 carriage square - SS	
15	60052	2	Screw, .375-16 x .750 standard hex, G5	
16	60206	2	Washer, .375 split lock	
17	A0000136598	1	Bracket, alternator mount	
18	60049	2	Screw, M8-1.25 x 25 standard hex, G8.8	
19	10000020581	1	Generator, Marathon 6KW, 60Hz CAP	
20	60037	2	Screw, M5 .80 x 20 pan Phillips, G4.8	
21	60087	4	Screw, M6-1.00 x 16 serrated flange hex, G8.8	
22	10000181267	4	Nut, M6 x 1.00 hex - insert	
23	A0000136599	1	Bracket, alternator junction box	
24	60747	1	Washer, .375 internal star	
25	60038	2	Nut, M5-.80 nylock	
--	A0000146735	1	Harness, 20A GFCIR	
--	A0000146736	1	Harness, generator to control 6KW	

Note: Generator parts used in all Generac Mobile Products, LLC equipment carry the Original Equipment Manufacturer (OEM) warranty unless otherwise stated. OEM warranty parts must be purchased through an OEM dealer. Please contact Generac Mobile Products, LLC with questions.

COMPONENTS TO TRAILER ASSEMBLY (1 OF 2)

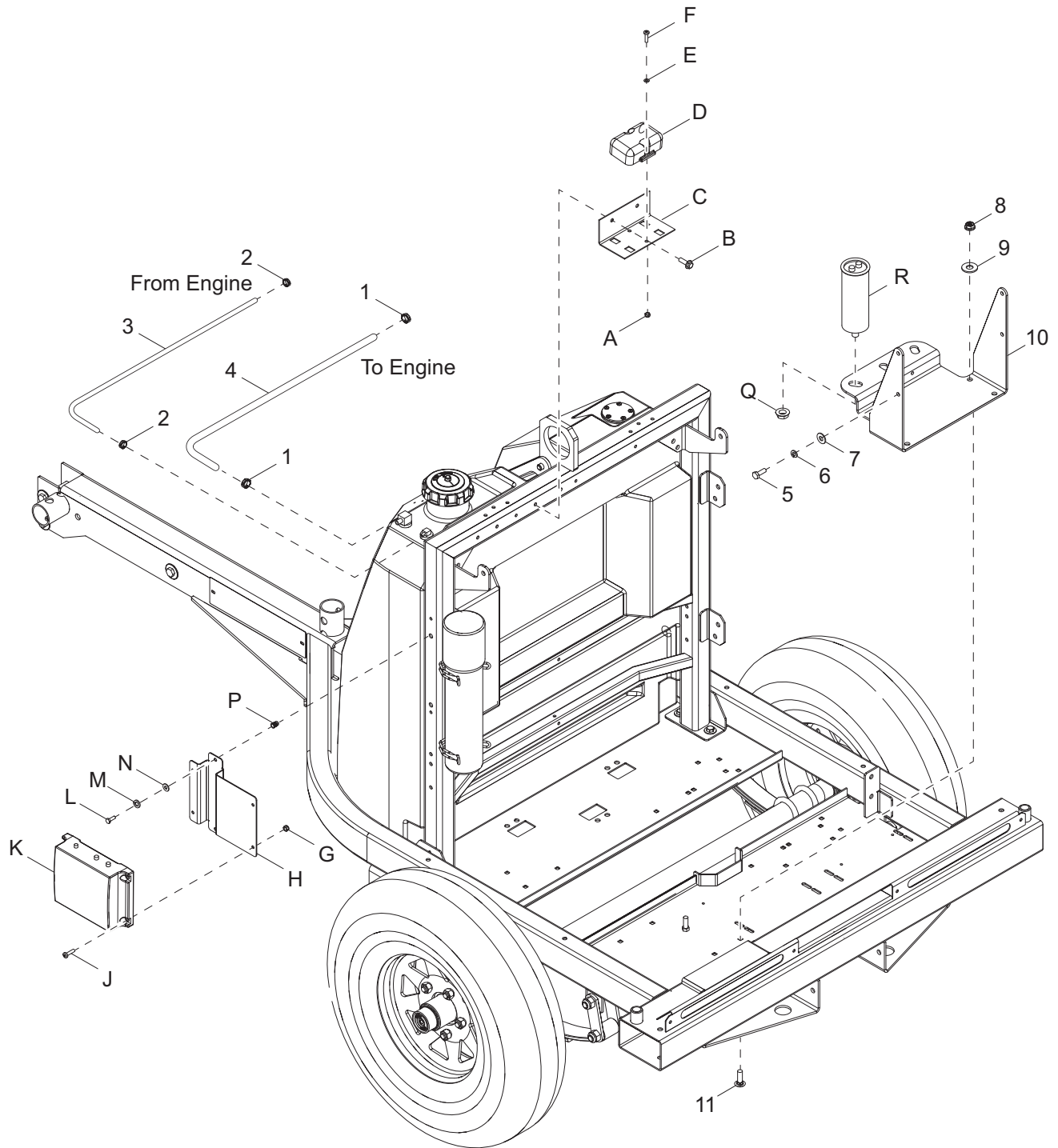

02889

COMPONENTS TO TRAILER ASSEMBLY (1 OF 2)

Item	Part No.	Qty	Description	Notes
1	60788	2	Clamp, hose .188 - crimp style	
2	60777	2	Clamp, hose .312 - crimp style	
3	14211	4.25 ft	Hose, fuel .188ID, 50 psi - SAE 30R7	
4	50018	3.33 ft	Hose, fuel .312ID, 50 psi - SAE 30R7	
5	60647	4	Screw, .250-20 x .500 standard hex, G5	
6	60286	4	Washer, .250 split lock	
7	60243	4	Washer, .250 flat	
8	60095	4	Nut, .312-18 serrated flange	
9	60119	4	Washer, .312 flat .875/.070	
10	A0000093872	1	Bracket, control box mounting	
11	61066	4	Screw, .312-18 x 1.00 carriage square - SS	
<i>Telemetry (If equipped):</i>				
A	60061	2	Nut, 10-32 nylock	
B	68429	2	Screw, .312-18 x .750 flanged hex, G2 self-tapping	
C	52231B	1	Bracket, telemetry	
D	37731	1	Telemetry, ZTR - M6H	
E	60237	2	Washer, #10 flat .495/.036	
F	60062	2	Screw, 10-32 x .750 pan Phillips, G2	
--	68432	1	Harness, telemetry	
<i>Battery Charger (If equipped):</i>				
G	60415	4	Nut, 10-32 nylock	
H	73218B	1	Bracket, battery charger	
J	60062	4	Screw, 10-32 x .750 pan Phillips, G2	
K	66212	1	Charger, battery 2-5A/1-10A, 3 stage, 2 output	
L	60281	2	Screw, .250-20 x .750 hex, G5	
M	60286	2	Washer, .250 split lock	
N	60243	2	Washer, .250 flat .735/.060	
P	63132	2	Insert, .250-20 splined .027-.165 grip - threaded	
--	68836	1	Harness, 12V, DC charger	
<i>6KW Generator (If equipped):</i>				
Q	60148	1	Nut, M12-1.75 serrated flange, G8.8	
R	36980	1	Capacitor, 25UF 5% 440VAC, stud mount - sealed	
	A0000243987	1	Capacitor, 12.5UF	1.4KW option only

COMPONENTS TO TRAILER ASSEMBLY (2 OF 2)

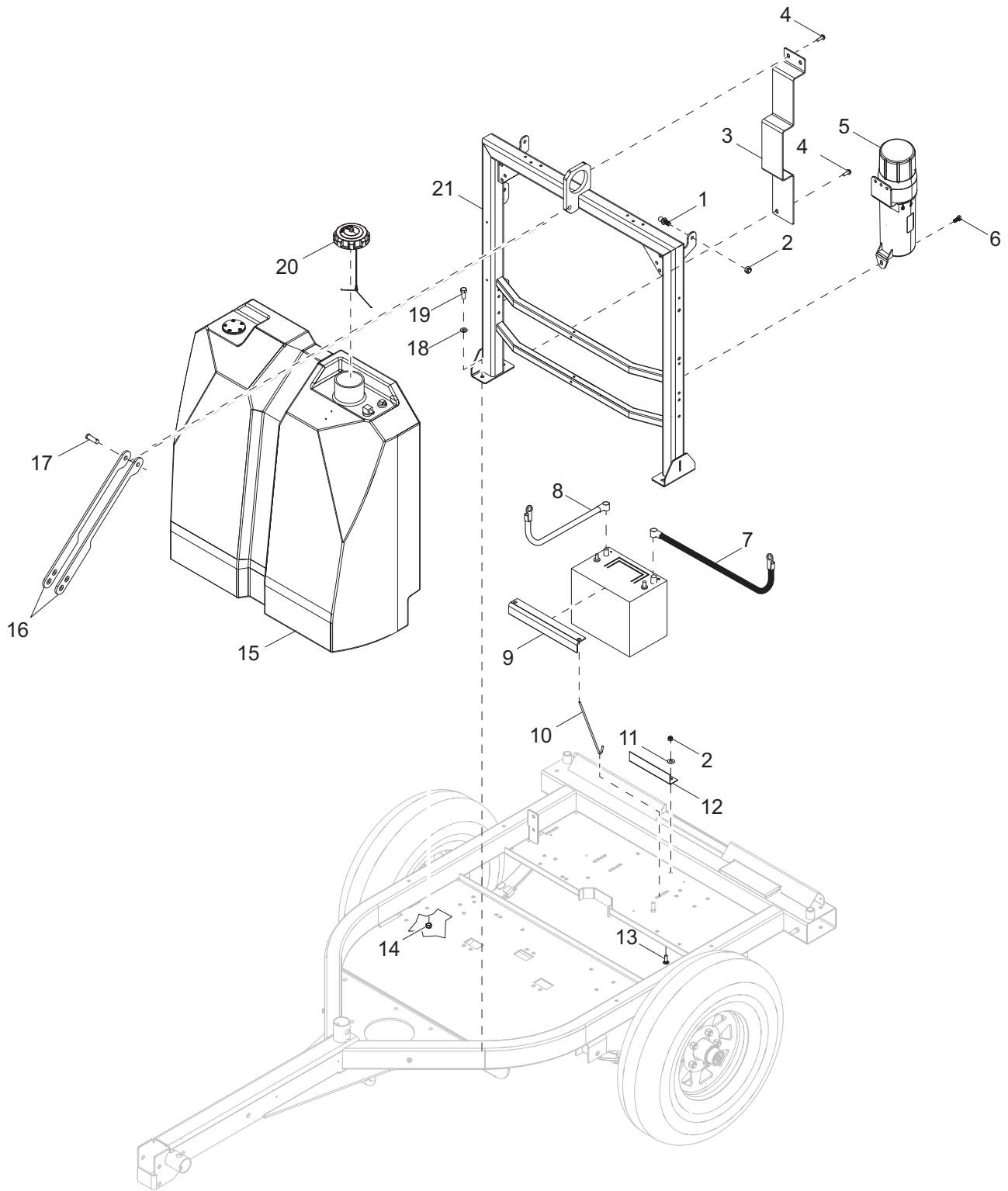

02630

COMPONENTS TO TRAILER ASSEMBLY (2 OF 2)

Item	Part No.	Qty	Description	Notes
1	35293	2	BALL STUD, 10MM, .313-18	
2	60303	4	NUT, .312-18 NYLOCK, G2	
3	A0004521399	1	STB BRACKET FUEL TANK BRACE	
4	68429	3	SCREW, .312-18 X .750 FLG HEX, G2 SELF-TAP	
5	36988	1	MANUAL HOLDER, 4 IN DIA. BLACK FOOT MTG	
6	60168	2	SCREW, .312-18X.750 STD HEX G5 ZC	
7	10699	1	CABLE, BATTERY 4 GAUGE - BLACK	
8	15074	1	CABLE, BATTERY 4 GAUGE - RED	
9	12924B	1	ANGLE, BATTERY HOLD-DOWN	
10	14146	2	BOLT, J, .250-20 X 10.0	
11	60119	2	WASHER, .312 FLAT .875/.07	
12	17992B	1	BRACKET, BATTERY STOP	
13	61066	2	SCREW, .312-18 X 1.00 CARRIAGE - SS	
14	60358	4	NUT, .375-16 NYLOCK, G5	
15	69919	1	TANK, FUEL - 42 GALLON W/SENDING UNIT	
16	39660B	2	BAR, CHASSIS SUPPORT	
17	63325	1	PIN, CLEVIS - .500 DIAMETER. X 1.063 UL, ZP	
18	60386	4	WASHER, .375 FLAT .993-.064	
19	60352	4	SCREW, .375-16 X 1.250 STANDARD HEX, G5	
20	16326	1	CAP, FUEL, 3.5 DIAMETER., DIESEL, VENT W/ TETHER	
21	10000023283	1	WELDMENT, LIFT SUPPORT	

TRAILER ASSEMBLY

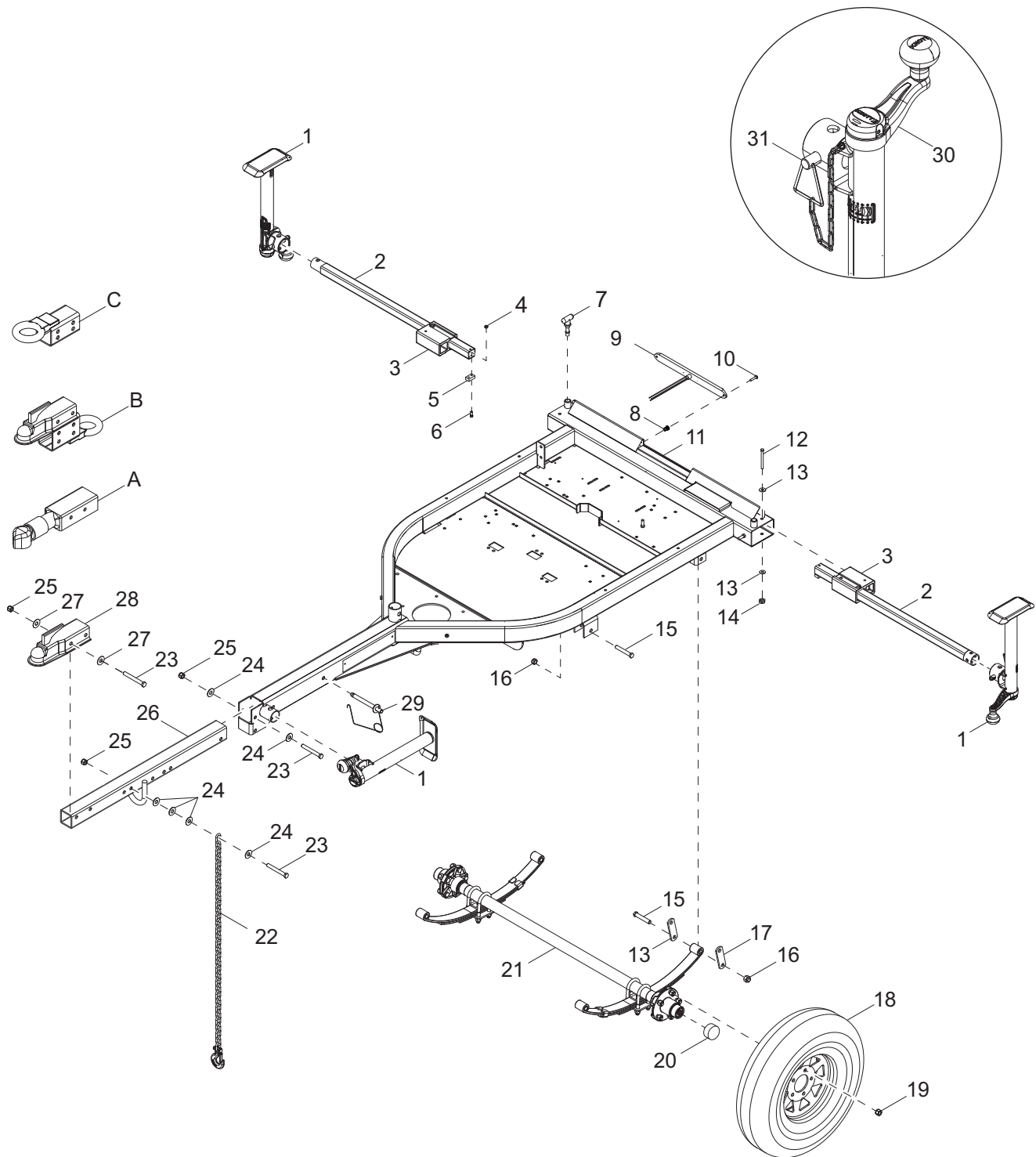

02890

TRAILER ASSEMBLY

Item	Part No.	Qty	Description	Notes
1	72126	3	JACK, TOP WIND - 1200 LB, TUBE MOUNTED	
2	70230ZY	2	WELDMENT, OUTRIGGER TUBE	
3	36869	2	GUIDE BLOCK (MOLDED) - OUTRIGGER	
4	60144	4	NUT, .250-20 NYLOCK, G5	
5	72128	2	PAD/STOP, WEAR - OUTRIGGER	
6	73196	4	SCREW, .250-20 X 2.25 SOCKET HEAD	
7	36890	3	SPRING PIN, HANDLE	
8	73092	4	INSERT, #8-32 .020-.080 GRIP - CLOSE SEALED	
9	36960	2	ASSEMBLY, TAIL LIGHT	
10	60694	4	SCREW, 8-32 X .750 PAN PHILLIPS	
11	10000021817	1	WELDMENT, LT CHASSIS	
12	60404	2	SCREW, .312-18 X 4.00 STANDARD HEX, G5	
13	60119	4	WASHER, .312 FLAT .875/.070	
14	60303	2	NUT, .312-18, NYLOCK, G2	
15	60503	6	SCREW, SHACKLE, .562-18 X 3.00 STANDARD HEX, G5	
16	60504	6	NUT, .562-18 LOCK HEX, G5	
17	19637	4	PLATE, SHACKLE BRACKET - 3.125"	
18	15976B	2	WHEEL, ST175/8013 - 1360 LB	
19	60096	10	NUT, .500-20 LUG, G5	
20	70150	2	CAP, DUST	
21	34760	1	AXLE, 2200LB 47TC 35SC	
22	23367	2	CHAIN, SAFETY - 7800 LBS RATED	
23	50215	5	SCREW, .500-13 X 4.00 STANDARD HEX, G5	
24	60416	10	WASHER, .500 FLAT 1.375/.090	
25	62221	5	NUT, .500-13 NYLOCK, G5	
26	17969B	1	WELDMENT, TILT TONGUE	
27	60309	4	WASHER, .500 FLAT 1.060/.090	
28	16830	1	COUPLER, 2.00 BALL/2.50 CHANNEL	
29	33943	2	PIN, LOCKING .500 X 3.50	
30	37155	1	HANDLE, JACK - TOP WIND	
31	39658	1	KIT, JACK PIN - BALL DETENT	
--	68348	1	HARNESS, TRAILER WIRING, TANDEM TOW	
--	68324	1	HARNESS, TRAILER ENCLOSURE FRONT	
--	10000020727	1	ASSEMBLY, HARNESS EXTENSION LOOMED	

Hitch Options (If equipped):

A	13003B	1	COUPLER, 2.00 BALL/3.00 CHANNEL, BULLDOG
B	34792ZC	1	WELDMENT, COMBINATION HITCH - 2.50 TONGUE
C	16835B	1	WELDMENT, LUNETTE RING 3.00 ID - 2.50 TONGUE
--	65548	1	ADAPTER, 4 PIN FLAT TO 4 PIN FLAT X 12.00

RECOMMENDED SPARE PARTS - ENGINE AND SERVICE KITS

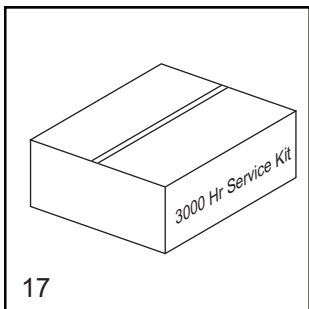
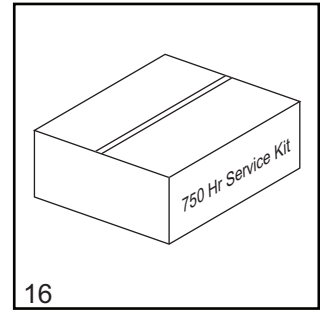
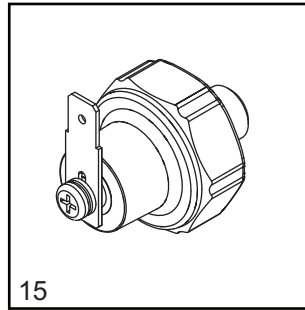
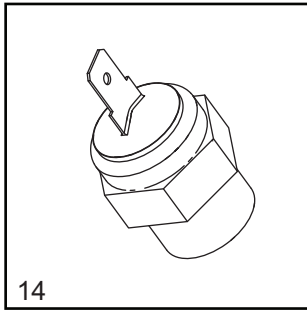
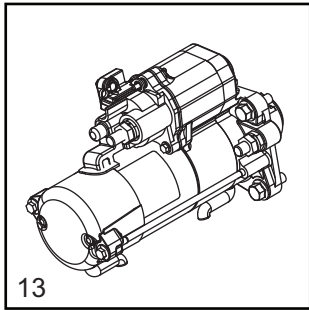
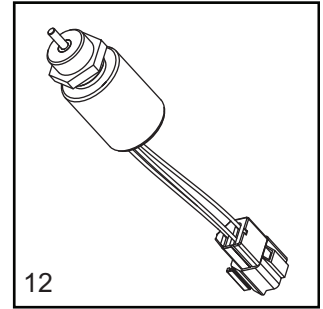
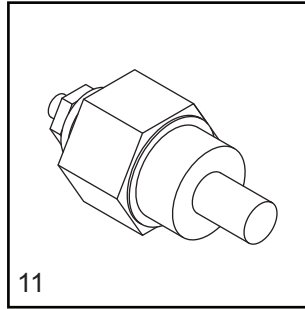
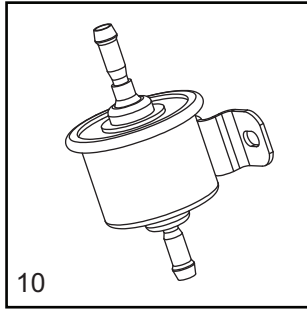
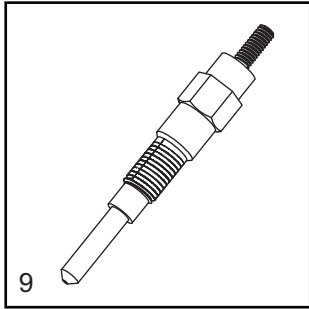
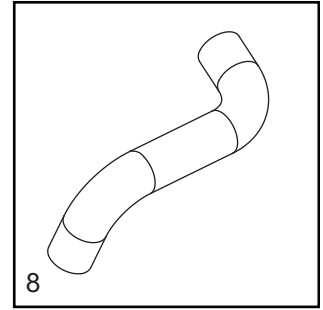
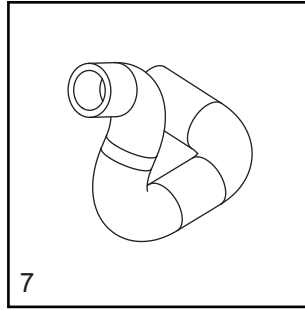
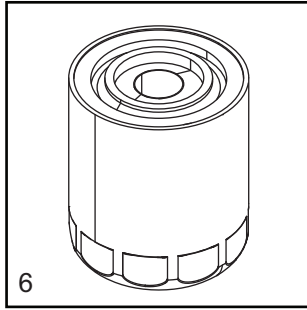
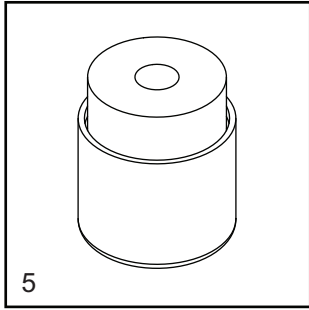
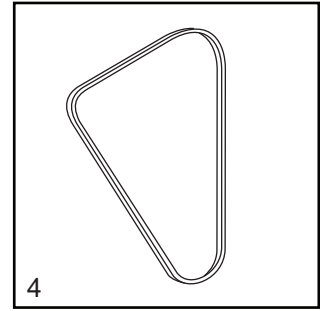
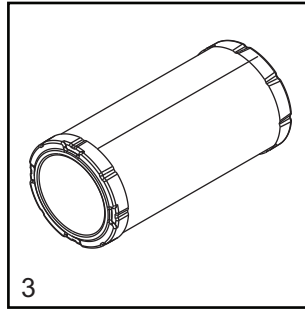
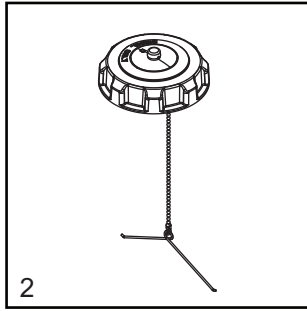
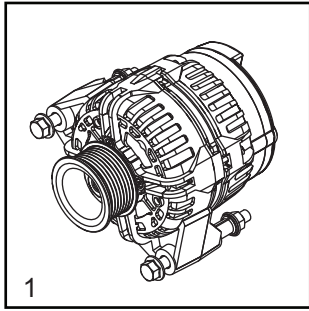

RECOMMENDED SPARE PARTS - ENGINE AND SERVICE KITS

ENGINE

1. ALTERNATOR	A0000083440
2. CAP, FUEL TANK WITH LANYARD	16326
3. FILTER, AIR (ELEMENT)	16444
4. BELT	72177
5. FILTER, FUEL, MITSUBISHI	10000023037
6. FILTER, OIL, MITSUBISHI	70124
7. HOSE, RADIATOR - LOWER	10000047331
8. HOSE, RADIATOR - UPPER	10000047702
9. ELEMENT, GLOW PLUG	16693SRV
10. PUMP, FUEL	13278SRV
11. SENDER, COOLANT TEMP	12873
12. SOLENOID, FUEL SHUTDOWN	16683
13. STARTER	70232
14. SWITCH, COOLANT TEMPERATURE	16678
15. SWITCH, OIL PRESSURE	16677

SERVICE KITS

16. 750 HOUR KIT	10000036108
INCLUDES: AIR FILTER ELEMENT 16444, FUEL FILTER ELEMENT 10000023037 AND OIL FILTER 70124	
17. 3000 HOUR KIT	SK335
INCLUDES: ENGINE BELT 72177 (2), AIR FILTER ELEMENT 16444 (4), FUEL FILTER ELEMENT 10000023037(4), AND OIL FILTER 70124 (4)	

RECOMMENDED SPARE PARTS - MISC

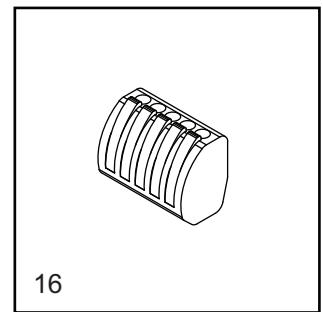
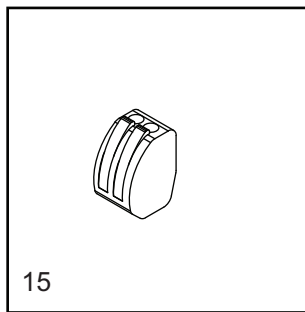
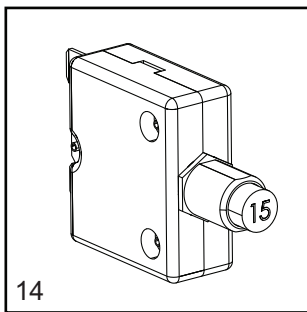
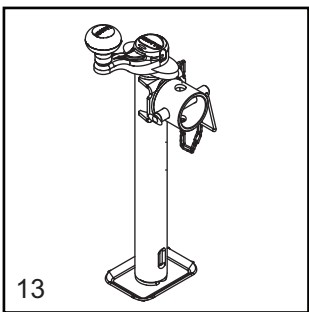
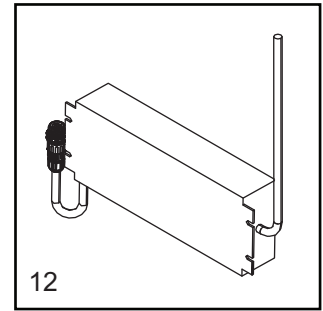
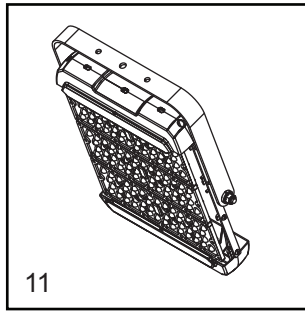
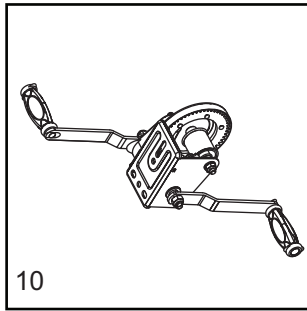
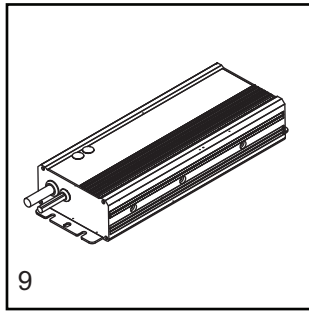
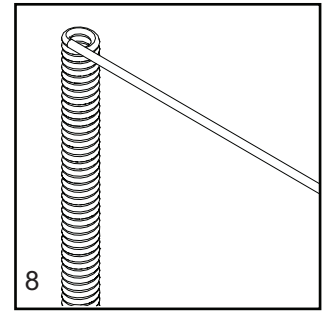
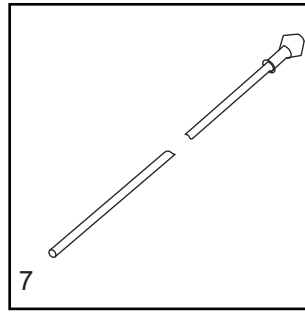
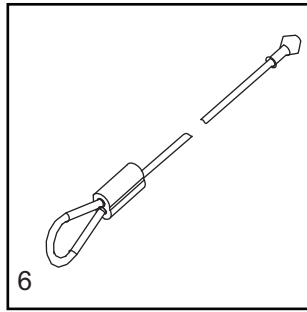
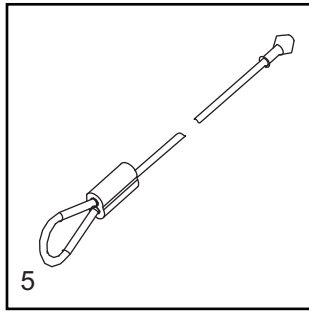
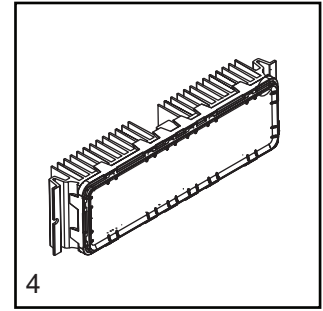
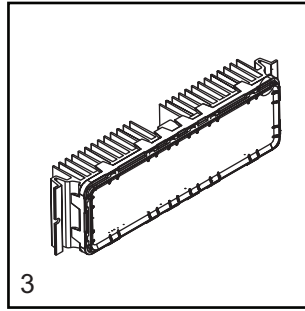
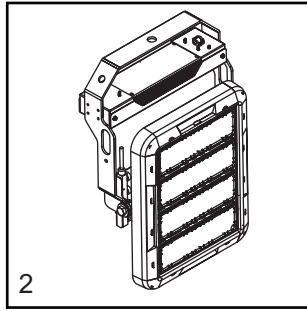
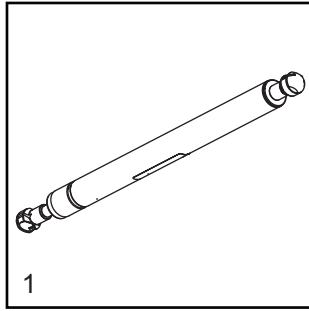

ENCLOSURE

1. GAS SHOCK 35137

MAST

2. ASSEMBLY, LED LIGHT 10000019145
3. MODULE 60 DEGREE LED 10000019170
4. MODULE 40 DEGREE LED 10000019160
5. CABLE, 79.75 IN 31248
6. CABLE, 78 IN 31277
7. CABLE, 144 IN 31247
8. COIL CORD W/ 155 INCH TAIL
(MAST JUNCTION BOX TO CONTROL BOX)..... A0000108466
9. DRIVER, LED 30V, 10.7A, 321W 72178
10. WINCH, MANUAL, INCLUDES DUAL HANDLE 72127
11. ASSEMBLY, LED LIGHT 320W - HARD WIRE A0000092363
12. ASSEMBLY, DRIVER WITH CONNECTOR A0000188779

JACKS

13. JACK, TOP WIND, 1200 LB 72126

ELECTRICAL

14. BREAKER, 15A, 250A, SINGLE POLE 36935
15. CONNECTOR 2 POSITION 66100
16. CONNECTOR 5 POSITION 66102

Part No. 10000043256 Rev. C 02/01/2024

©2024 Generac Power Systems, Inc.
All rights reserved.
Specifications are subject to change without notice.
No reproduction allowed in any form without prior written consent
from Generac Power Systems, Inc.

GENERAC | **MOBILE**

Generac Power Systems, Inc.
S45 W29290 Hwy. 59, Waukesha WI 53189
[GeneracMobileProducts.com](https://www.GeneracMobileProducts.com) | 844-ASK-GNRC | 844-275-4672