

Owner's Manual

Diesel Generator

MMG25IF4 • MMG35DF4 • MMG45IF4 • MMG55DF4

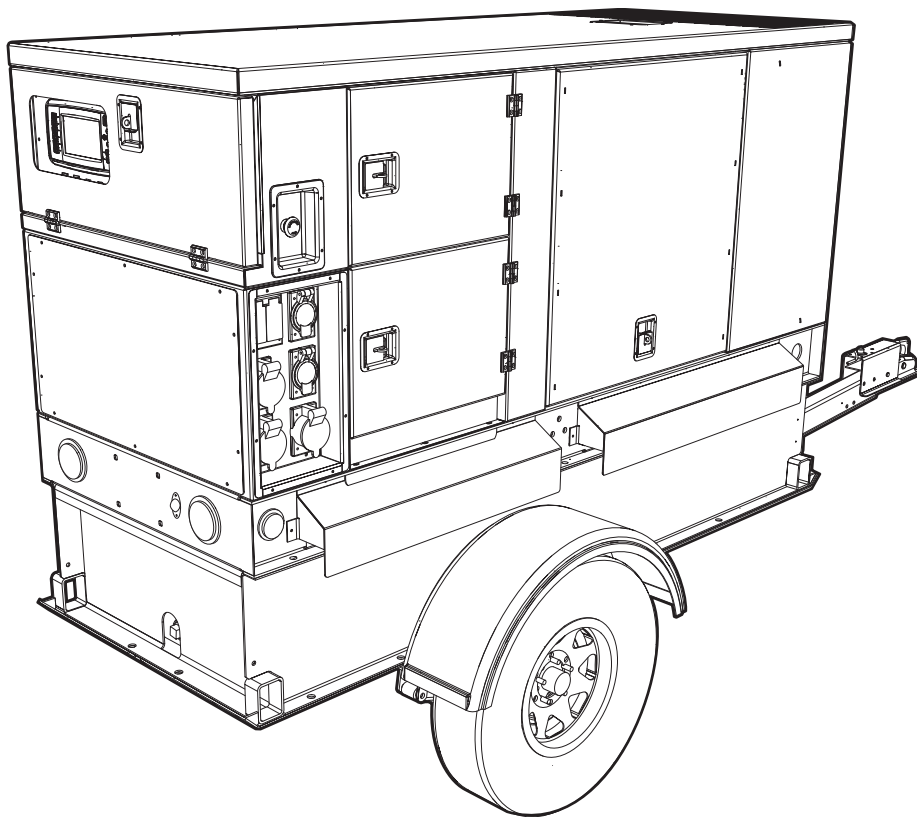

For technical assistance contact:

www.generacmobileproducts.com

Technical Support

1-800-926-9768

SAVE THIS MANUAL FOR FUTURE REFERENCE

Use this page to record important information about your unit

Unit Model No.	
Unit Serial No.	
Engine Model No.	
Engine Serial No.	
Generator Model No.	
Generator Serial No.	
Date Purchased	

Record the information found on your unit data label on this page. See [Unit and Serial Number Locations](#).

Engine and generator serial numbers are located on separate data plates affixed to the engine and generator respectively.

When contacting a Generac Mobile Authorized Service Dealer (GMASD) about parts and service, always supply the complete model number and serial number of the unit.

Operation and Maintenance: Proper maintenance and care of the unit ensures a minimum number of problems and keeps operating expenses at a minimum. It is the operator's responsibility to perform all safety checks, to verify that all maintenance for safe operation is performed promptly, and to have the equipment checked periodically by a GMASD. Normal maintenance, service and replacement of parts are the responsibility of the owner/operator and, as such, are not considered defects in materials or workmanship within the terms of the warranty. Individual operating habits and usage may contribute to the need for additional maintenance or service.

 **WARNING**

CANCER AND REPRODUCTIVE HARM

www.P65Warnings.ca.gov.

(000393a)

 **WARNING**

Breathing diesel engine exhaust exposes you to chemicals known to the State of California to cause cancer and birth defects or other reproductive harm.

- Always start and operate the engine in a well-ventilated area.
- If in an enclosed area, vent the exhaust to the outside.
- Do not modify or tamper with the exhaust system.
- Do not idle the engine except as necessary.

For more information go to

www.P65Warnings.ca.gov/diesel.

(000394)

Table of Contents

Section 1: Introduction and Safety

Introduction	1
Read This Manual Thoroughly	1
How to Obtain Service	1
Safety Rules	1
General Hazards	2
Trailer Hazards	2
Electrical Hazards	3
Lifting Hazards	3
Explosion and Fire Hazards	3
Battery Hazards	4
Fuel Hazards	4
Engine Safety	4
Operating Safety	4
Positioning the Unit	4
Starting the Unit	5
Lowering Trailer Tongue	5
Towing Safety	5
Hitch and Coupling	5
Safe Towing Techniques	6
Reporting Trailer Safety Defects	6
Safety and Operating Decals	7

Section 2: General Information

Specifications	11
Unit Dimensions	13
Unit and Serial Number Locations	14
Altitude and Temperature Limitations	14
Component Locations	15
Exterior	15
Connection Panel	16
Control Panel	17
Genset Controller	18
Controller Modes	20
Operator Pages	20
Maintenance Alarms	22
Generator Monitoring	22
Engine Monitoring	22
Controller Information Displays, Functions, and Re-set	23
Voltage Selector Switch	23

Section 3: Operation

Pre-start Checklist	25
Manually Starting the Unit	25
AUTO (Remote) Starting the Unit	26
Wet Stacking	27
Cold Weather Features (if equipped)	27
Using a Booster Battery or Charger (if equipped) ..	28
Generator Output Connections	29
Generator Cam Lock Connections (If Equipped)	29
Using the Voltage Selector Switch	30
Fine Tuning the Voltage	30
Voltage Regulator	30
Achieving 240V Three-Phase in 208V Three-Phase (Parallel Low Wye) Configuration	31
Changing Back to 208V Configuration	31
Customer Convenience Receptacles	31
Main Circuit Breaker	32
DOC and SCR Cleaning Operations	32
Disabling Automatic (AUTO) Exhaust After-Treatment Cleaning (If Equipped)	32
Force a Manual Exhaust After-Treatment Cleaning ..	32
Enable Exhaust After-Treatment Cleaning	33
Transfer Switch	33
AUTO Exercise Timer	33
Accessing the Configuration Menu	33
Set the Controller Clock	34
Set the Schedule	34
Setting Up a Daily Scheduled Run	34
Set the Unit to AUTO Mode	34
Shutting Down the Unit	34
Emergency Stop Switch	35
Idle Switch	35
Using ECU Override	35
Towing the Unit	35
Lifting the Unit	36

Section 4: Maintenance

Emissions Information	37
Maintenance	37
Daily Walk Around Inspection	37
Belt Tensioners	37
General Maintenance	37
Engine Oil Recommendations	38
Coolant Recommendation	38

Basic Maintenance Schedule	39
Engine Break-In Requirements—Isuzu	41
Engine Break-In Requirements—John Deere	41
Resetting Maintenance Alarms	41
Exhaust Filter Service Requirements	41
Checking Generator Drive Plate Torque	41
Jack Maintenance	42
Side-Wind Models	42
Top-Wind Models	42
Trailer Wheel Bearings	42

Section 5: Troubleshooting

General Troubleshooting	43
-------------------------------	----

Section 6: Wiring Diagrams

3-Position AC Box	45
3-Position AC Box	46
4-Position AC Box	47
4-Position AC Box	48
Receptacles	49
Engine Heater	49
Wiring Buck (If Equipped)	50
Power Zone PMG	50
Power Zone Control Box	51
Trailer Lights	52
Brake Wiring	53
12-Volt Battery Charger	54
Power Zone Low Oil Level (If Equipped)	54

Section 1: Introduction and Safety

Introduction

Thank you for purchasing a Generac Mobile product. This unit has been designed to provide high performance, efficient operation, and years of use when maintained properly.

The information in this manual is accurate based on products produced at the time of publication. The manufacturer reserves the right to make technical updates, corrections, and product revisions at any time without notice.

Read This Manual Thoroughly



Consult Manual. Read and understand manual completely before using product. Failure to completely understand manual and product could result in death or serious injury. (000100a)

If any section of the manual is not understood, contact your nearest GMASD, or contact Generac Mobile at 1-800-926-9768, or Generac Mobile Technical Service at 1-800-926-9768 or www.generacmobileproducts.com with any questions or concerns.

The owner is responsible for proper maintenance and safe use of the equipment. Comply with regulations the Occupational Safety and Health Administration (OSHA) has established, or with equivalent standards. Also, verify that the unit is applied, used, and maintained in accordance with the manufacturer's instructions and recommendations. Do nothing that might alter safe application/usage and render the unit in noncompliance with the aforementioned codes, standards, laws, and regulations.

Save these instructions for future reference. This manual contains important instructions for the unit that should be followed during setup, operation and maintenance of the unit and battery. ALWAYS supply this manual to any individual that will use this machine.

How to Obtain Service

When the unit requires servicing or repairs, contact a GMASD) for assistance. Service technicians are factory-trained and are capable of handling all service needs. For assistance locating a dealer, visit www.generacmobileproducts.com/parts-service/find-service. When contacting a GMASD about parts and service, always supply the complete model number and serial number of the unit as given on its data decal located on the unit. Record the model number and serial numbers in the spaces provided on the inside front cover of this manual.

Safety Rules

The manufacturer cannot anticipate every possible circumstance that might involve a hazard. The warnings in this manual, and on tags and decals affixed to the unit are, therefore, not all inclusive. If using a procedure, work method or operating technique that the manufacturer does not specifically recommend, verify that it is safe for others. Also make sure the procedure, work method or operating technique utilized does not render the equipment unsafe.

Throughout this publication, and on tags and decals affixed to the unit, DANGER, WARNING, CAUTION and NOTE blocks are used to alert personnel to special instructions about a particular operation that may be hazardous if performed incorrectly or carelessly. Observe them carefully. Their definitions are as follows:



Indicates a hazardous situation which, if not avoided, will result in death or serious injury.

(000001)



Indicates a hazardous situation which, if not avoided, could result in death or serious injury.

(000002)



Indicates a hazardous situation which, if not avoided, could result in minor or moderate injury.

(000003)

NOTE: Notes contain additional information important to a procedure and will be found within the regular text of this manual.

These safety alerts cannot eliminate the hazards that they indicate. Common sense and strict compliance with the special instructions while performing the action or service are essential to preventing accidents.

General Hazards



⚠ DANGER

Asphyxiation. Running engines produce carbon monoxide, a colorless, odorless, poisonous gas. Carbon monoxide, if not avoided, will result in death or serious injury. (000103)



⚠ DANGER

Asphyxiation. Do not operate unit without a properly functioning exhaust system. Doing so will result in death or serious injury. (000340)



⚠ WARNING

Loss of life. This product is not intended to be used in a critical life support application. Failure to adhere to this warning could result in death or serious injury. (000209b)



⚠ WARNING

Hearing Loss. Hearing protection is recommended when using this machine. Failure to wear hearing protection could result in permanent hearing loss. (000107)



⚠ WARNING

Vision loss. Eye protection is required when operating unit. Failure to wear appropriate eye protection could result in vision loss or serious injury. (000407)



⚠ WARNING

Moving Parts. Keep clothing, hair, and appendages away from moving parts. Failure to do so could result in death or serious injury. (000111)



⚠ WARNING

Hot Surfaces. When operating machine, do not touch hot surfaces. Keep machine away from combustibles during use. Hot surfaces could result in severe burns or fire. (000108)

⚠ WARNING

Equipment damage. Do not attempt to start or operate a unit in need of repair or scheduled maintenance. Doing so could result in serious injury, death, or equipment failure or damage. (000291)

⚠ WARNING

Risk of injury. Do not operate or service this machine if not fully alert. Fatigue can impair the ability to operate or service this equipment and could result in death or serious injury. (000215a)



⚠ WARNING

Risk of burns. Allow engine to cool before draining oil or coolant. Failure to do so could result in death or serious injury. (000139)

⚠ WARNING

Equipment damage. Only qualified service personnel may install, operate, and maintain this equipment. Failure to follow proper installation requirements could result in death, serious injury, and equipment or property damage. (000182a)

⚠ CAUTION

Equipment or property damage. Do not block air intake or restrict proper air flow. Doing so could result in unsafe operation or damage to unit. (000229)

Trailer Hazards

⚠ WARNING

Personal injury. Trailer must be securely coupled to the hitch with the chains correctly attached. Uncoupled or unchained towing could result in death or serious injury. (000233a)

⚠ WARNING

Personal injury. Do not operate unit during transport. Doing so could result in death, serious injury, or property damage. (000231a)

⚠ WARNING

Crushing hazard. Verify unit is properly secured and on level ground. An unsecured unit can suddenly roll or move, causing death or serious injury. (000234a)

⚠ WARNING

Property or Equipment Damage. Tighten wheel lug nuts after first 50 miles to factory specifications. Failure to do so could result in death, serious injury, property or equipment damage. (000235)

Electrical Hazards



⚠ DANGER

Electrocution. In the event of electrical accident, immediately shut power OFF. Use non-conductive implements to free victim from live conductor. Apply first aid and get medical help. Failure to do so will result in death or serious injury. (000145)



⚠ DANGER

Electrocution. Water contact with a power source, if not avoided, will result in death or serious injury.

(000104)



⚠ DANGER

Electrocution. Contact with bare wires, terminals, and connections while generator is running will result in death or serious injury.

(000144)



⚠ DANGER

Electrocution. Verify electrical system is properly grounded before applying power. Failure to do so will result in death or serious injury.

(000152)



⚠ DANGER

Electrocution. Turn utility supply OFF before working on utility connections of the transfer switch. Failure to do so will result in death or serious injury.

(000123)



⚠ DANGER

Electrocution. Never connect this unit to the electrical system of any building unless a licensed electrician has installed an approved transfer switch. Failure to do so will result in death or serious injury.

(000150)



⚠ WARNING

Explosion. Batteries emit explosive gases. Always disconnect negative battery cable first to avoid spark. Failure to do so could result in death or serious injury.

(000238)

Lifting Hazards



⚠ WARNING

Personal injury. Failure to properly connect lifting cables, chains, or straps could result in death, serious injury, or property damage.

(000346)

⚠ WARNING

Personal Injury. Do not use lifting eye if there are signs of damage or corrosion. Doing so could result in death, serious injury, or property damage.

(000433)

⚠ WARNING

Personal Injury. Do not use lifting eye other than as directed. Doing so could result in death, serious injury, or property damage.

(000434)

⚠ WARNING

Personal Injury. Verify all fasteners are properly tightened prior to lifting unit. Failure to do so could result in death, serious injury, or property damage.

(000351)

Explosion and Fire Hazards



⚠ DANGER

Explosion and Fire. Fuel and vapors are extremely flammable and explosive. Add fuel in a well ventilated area. Keep fire and spark away. Failure to do so will result in death or serious injury.

(000105)



⚠ WARNING

Fire risk. Fuel and vapors are extremely flammable. Do not operate indoors. Doing so could result in death, serious injury, or property or equipment damage.

(000281)



⚠ WARNING

Risk of Fire. Unit must be positioned in a manner that prevents combustible material accumulation underneath. Failure to do so could result in death or serious injury.

(000147)

Battery Hazards



⚠ DANGER

Electrocution. Do not wear jewelry while working on this equipment. Doing so will result in death or serious injury.

(000188)



⚠ WARNING

Explosion. Batteries emit explosive gases while charging. Keep fire and spark away. Wear protective gear when working with batteries. Failure to do so could result in death or serious injury.

(000137a)



⚠ WARNING

Explosion. Do not dispose of batteries in a fire. Batteries are explosive. Electrolyte solution can cause burns and blindness. If electrolyte contacts skin or eyes, flush with water and seek immediate medical attention.

(000162)



⚠ WARNING

Risk of burn. Do not open or mutilate batteries. Batteries contain electrolyte solution which can cause burns and blindness. If electrolyte contacts skin or eyes, flush with water and seek immediate medical attention.

(000163a)

⚠ WARNING

Environmental Hazard. Always recycle batteries at an official recycling center in accordance with all local laws and regulations. Failure to do so could result in environmental damage, death, or serious injury.

(000228)

Fuel Hazards



⚠ DANGER

Explosion and fire. Fuel and vapors are extremely flammable and explosive. No leakage of fuel is permitted. Keep fire and spark away. Failure to do so will result in death or serious injury.

(000192)



⚠ DANGER

Risk of fire. Allow fuel spills to completely dry before starting engine. Failure to do so will result in death or serious injury.

(000174)

- **DO NOT** fill fuel tank near an open flame, while smoking, or while engine is running. **DO NOT** fill tank in an enclosed area with poor ventilation.
- **DO NOT** operate with the fuel tank cap loose or missing.

Engine Safety

Internal combustion engines present special hazards during operation and fueling. Failure to follow the safety guidelines described below could result in severe injury or death. Read and follow all safety alerts described in the engine operator's manual. A copy of this manual was supplied with the unit when it was shipped from the factory.

- **DO NOT** run engine indoors or in an area with poor ventilation. Verify engine exhaust cannot seep into closed rooms or ventilation equipment.
- **DO NOT** clean air filter with gasoline or other types of low flash point solvents.
- **DO NOT** operate the unit without a functional exhaust system.
- Shut the engine down if any of the following conditions exist during operation:
 - Noticeable change in engine speed.
 - Loss of electrical output.
 - Equipment connected to the unit overheats.
 - Sparking occurs.
 - Engine misfires or there is excessive engine/generator vibration.
 - Protective covers are loose or missing.
 - Ambient air temperature is above 113 °F (45 °C).

Operating Safety

Positioning the Unit



⚠ DANGER

High Voltage. Verify area above unit is clear of overhead wires and obstructions. Contact with high-voltage power lines will result in death or serious injury.

(000260a)



⚠ WARNING

Risk of Fire. Unit must be positioned in a manner that prevents combustible material accumulation underneath. Failure to do so could result in death or serious injury.

(000147)

⚠ WARNING

Equipment and property damage. Do not operate unit on uneven surfaces, or areas of excessive moisture, dirt, dust or corrosive vapors. Doing so could result in death, serious injury, property and equipment damage.

(000250)

⚠ WARNING

Crushing hazard. Verify unit is properly secured and on level ground. An unsecured unit can suddenly roll or move, causing death or serious injury.

(000234a)

- The area immediately surrounding the unit should be dry, clean, and free of debris.
- If the unit is equipped with a frame grounding stud, follow any local, state, and National Electrical Code (NEC) guidelines when connecting.

Starting the Unit



⚠ DANGER

Electrocution. **DO NOT** use the unit if electrical cord is cut or worn through. Doing so will result in death or serious injury.

(000263a)

⚠ WARNING

Equipment damage. Do not attempt to start or operate a unit in need of repair or scheduled maintenance. Doing so could result in serious injury, death, or equipment failure or damage.

(000291)

Lowering Trailer Tongue

For units shipped with the trailer tongue in the upright position, follow the steps below to lower the tongue.

1. Elevate the unit using a hoist or forklift, or use the jack located on the trailer tongue.

NOTE: If using the front jack for support, it must first be moved to the jack mount location nearest the frame.

2. See [Figure 1-1](#) Remove the mounting hardware securing the tongue shipping brace to the trailer frame (A).

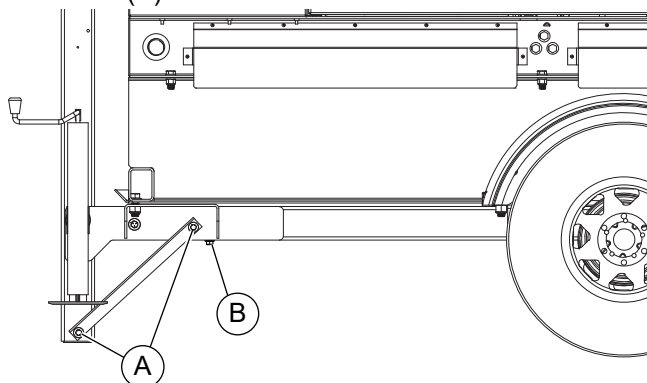

Figure 1-1. Lowering Trailer Tongue

3. Remove the shipping brace and slide it into the trailer tube opening. Secure the brace to the trailer with the bolt located on the underside of the trailer (B) and a new nylon locking nut.
4. See [Figure 1-2](#) Flip the trailer tongue down and reinstall the bolts and washers removed in step two using two new nylon locking nuts (C). **DO NOT**

reuse the nylon locking nuts. Tighten the bolts to 80–109 ft-lb (108–148 Nm).

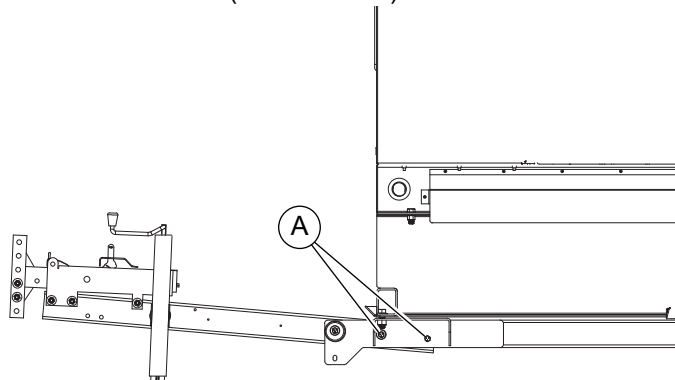

Figure 1-2. Lowering Trailer Tongue

NOTE: If the jack was used to support the unit while removing the shipping brace, the jack must be moved back to the tongue location before the unit can be towed. Connect the trailer tongue to a vehicle or other support and move the jack to the tongue location.

5. Tighten the bolt inside the jack mounting tube nearest the frame.
6. See [Figure 1-3](#) Remove the mounting hardware from the front hood actuator clearance hole panel (D). Tilt the panel forward. Reinstall the hardware to secure the panel.

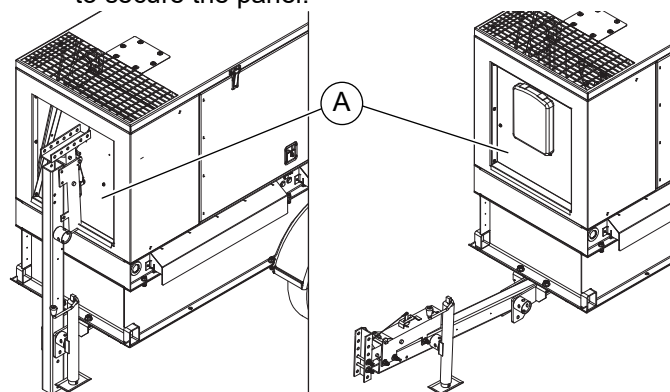

Figure 1-3. Lowering Trailer Tongue

Towing Safety

Towing a trailer requires care. Both the trailer and vehicle must be in good condition and securely fastened to each other to reduce the possibility of an accident. Some states require that large trailers be registered and licensed. Contact your local Department of Transportation office to check on license requirements for your particular unit.

Hitch and Coupling

- Verify the hitch and coupling on the towing vehicle are rated equal to, or greater than, the trailer's Gross Vehicle Weight Rating (GVWR).
- Verify the trailer hitch and the coupling are compatible. Verify the coupling is securely fastened to the vehicle.

- **DO NOT** tow trailer using defective parts. Inspect the hitch and coupling for wear or damage.
- Connect safety chains in a crossing pattern under the tongue.
- Before towing the unit, verify the weight of the trailer is equal across all tires. On trailers with adjustable height hitches, adjust the angle of the trailer tongue to keep the trailer as level as possible.

Safe Towing Techniques

- Practice turning, stopping and backing up in an area away from heavy traffic prior to transporting the unit.
- Maximum recommended speed for highway towing is 45 mph (72 km/h). Recommended off-road towing speed is 10 mph (16 km/h) or less, depending on terrain.
- When towing, maintain extra space between vehicles and avoid soft shoulders, curbs, sharp maneuvers, and sudden lane changes.
- Some conditions encountered while towing will require the operator to decrease towing speed and exercise caution. These conditions include but are not limited to steep grades, curves, adverse weather conditions, rough driving surfaces, slippery driving surfaces, and road geometries that require sharp maneuvers.

Reporting Trailer Safety Defects

If you believe your trailer has a defect which could cause a crash or could cause injury or death, you should immediately inform the National Highway Traffic Safety Administration (NHTSA) in addition to notifying Generac Mobile.

If NHTSA receives similar complaints, it may open an investigation; and if it finds that a safety defect exists in a group of vehicles, it may order a recall and remedy campaign. However, NHTSA cannot become involved in an individual problem between you, your GMASD, or Generac Mobile.

To contact NHTSA, you may either call the Auto Safety Hotline toll-free at 1-888-327-4236 (TTY: 1-800-424-9153), go to <http://www.safercar.gov>; or write to:

Administrator
NHTSA
1200 New Jersey Avenue S.E.
Washington, DC 20590

You can also obtain other information about motor vehicle safety from <http://www.safercar.gov>.

Safety and Operating Decals

This unit features numerous safety and operating decals. These decals provide important operating instructions and warn of dangers and hazards. The following diagrams illustrate decal locations and descriptions.

Replace any missing or hard-to-read decals and use care when washing or cleaning the unit. Decal part numbers can be found in the parts manual at www.generacmobileproducts.com.

ID	Description	ID	Description
1	Towing Instructions	18	Open Upper Door First
2	Ultra Low Sulfur Fuel Only	19	F4 Control
3	Danger: Diesel Fuel	20	Terminal Connections (Voltage Selector Switch)
4	Tie-Down Location	21	Remote Start Terminal Connections
5	Oil Drain	22	Circuit Breaker
6	Coolant Drain	23	CAN Lock Connectors
7	Warning: Hot Surface	24	Connection Terminal Lugs
8	Unit Lift Point	25	Clutch Fan
9	Warning: Automatic Starting	26	Fuel Heater
10	Electric Shock Hazard	27	Start/Prestart
11	Warning: Hot Surface	28	Fuel Transfer
12	Do Not Operate with Guards Removed	29	Danger: Read Owner's Manual Before Operation
13	Ground	30	Circuit Breaker
14	Battery Disconnect	31	Breaker
15	Secondary Filter	32	F4 Control
16	Primary Filter	33	Read Owner's Manual Before Operation
17	Warning: Hot Surface/Moving Parts	—	—

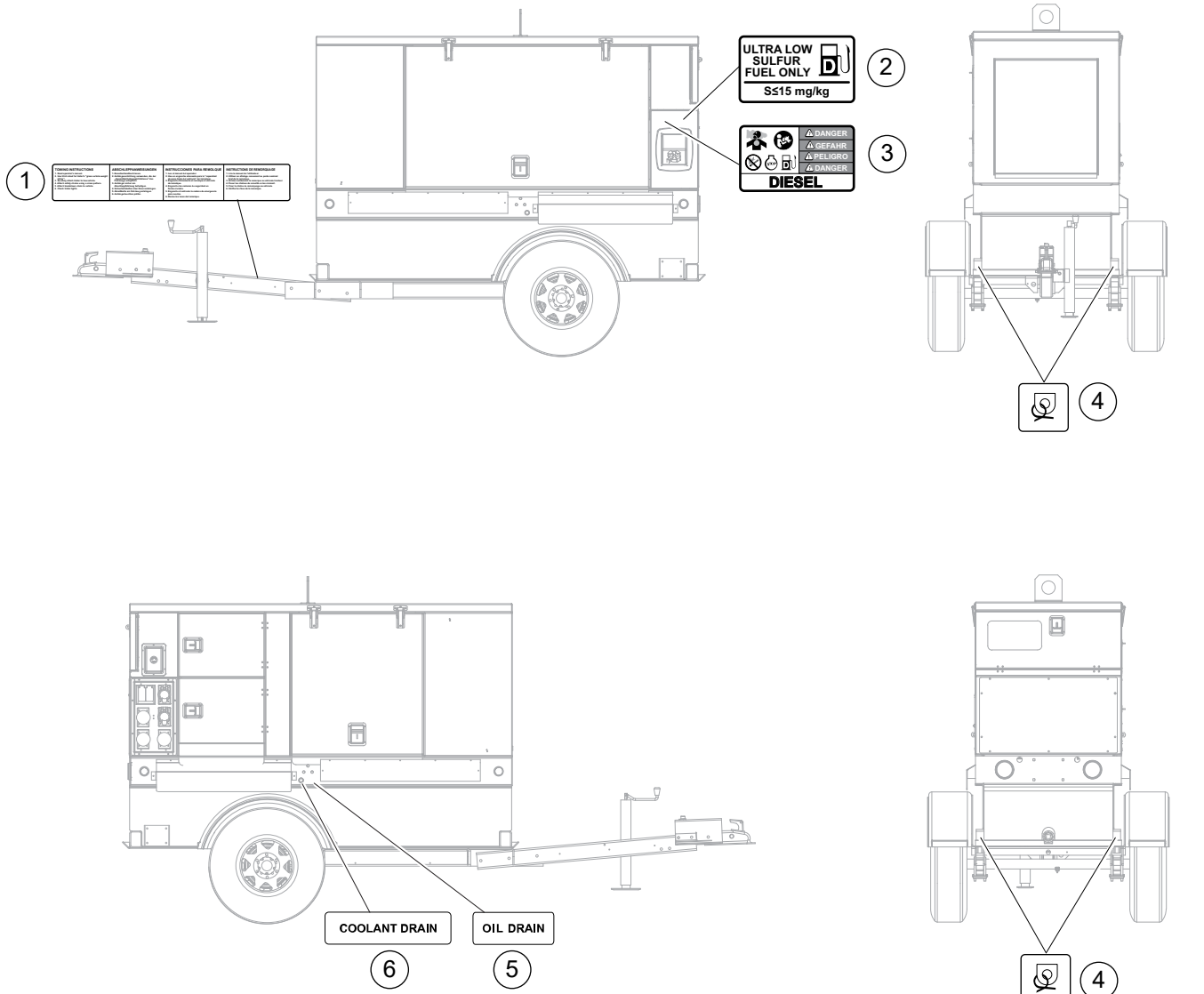

00808

Figure 1-4. Exterior Decals

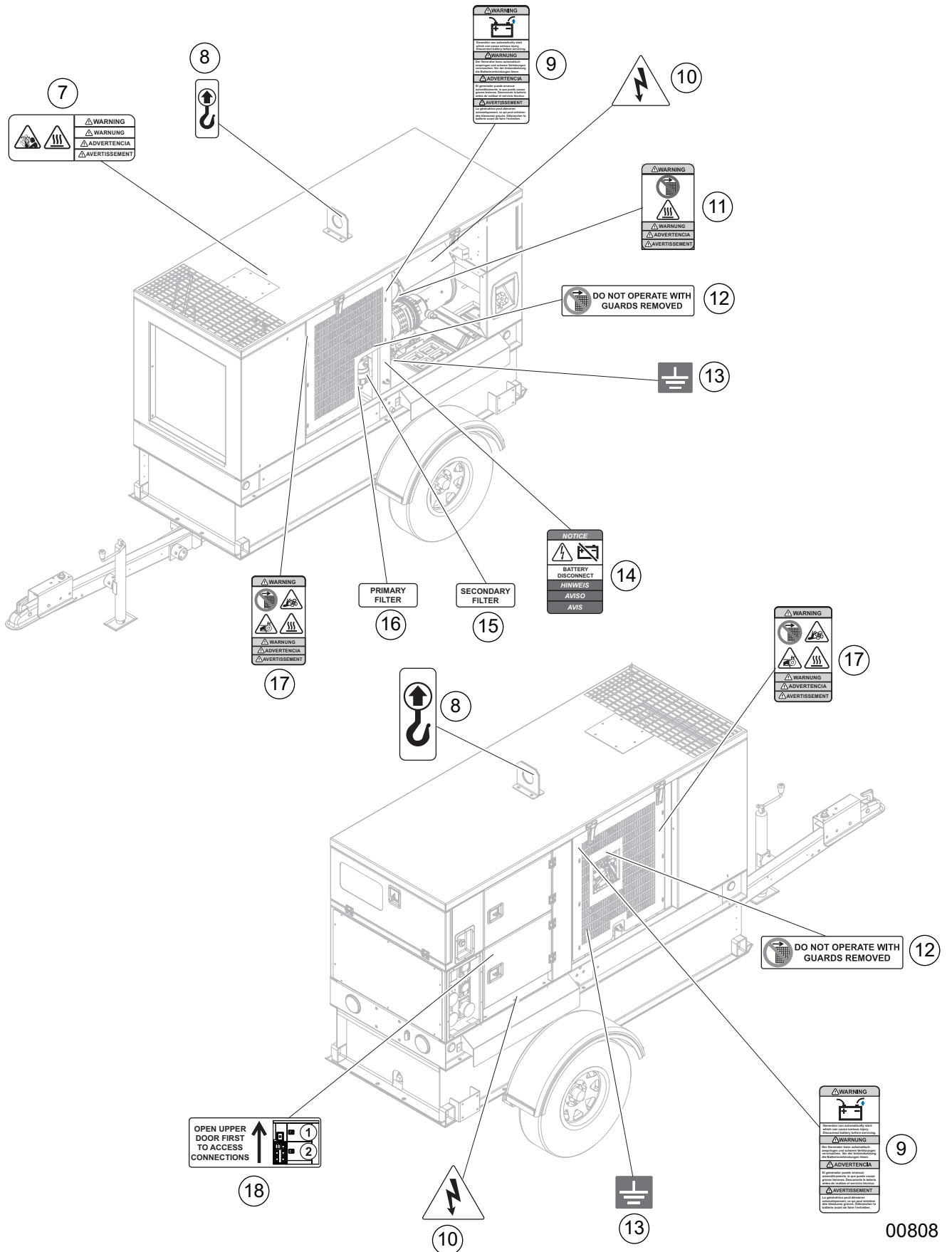

Figure 1-5. Left Side Interior Decals

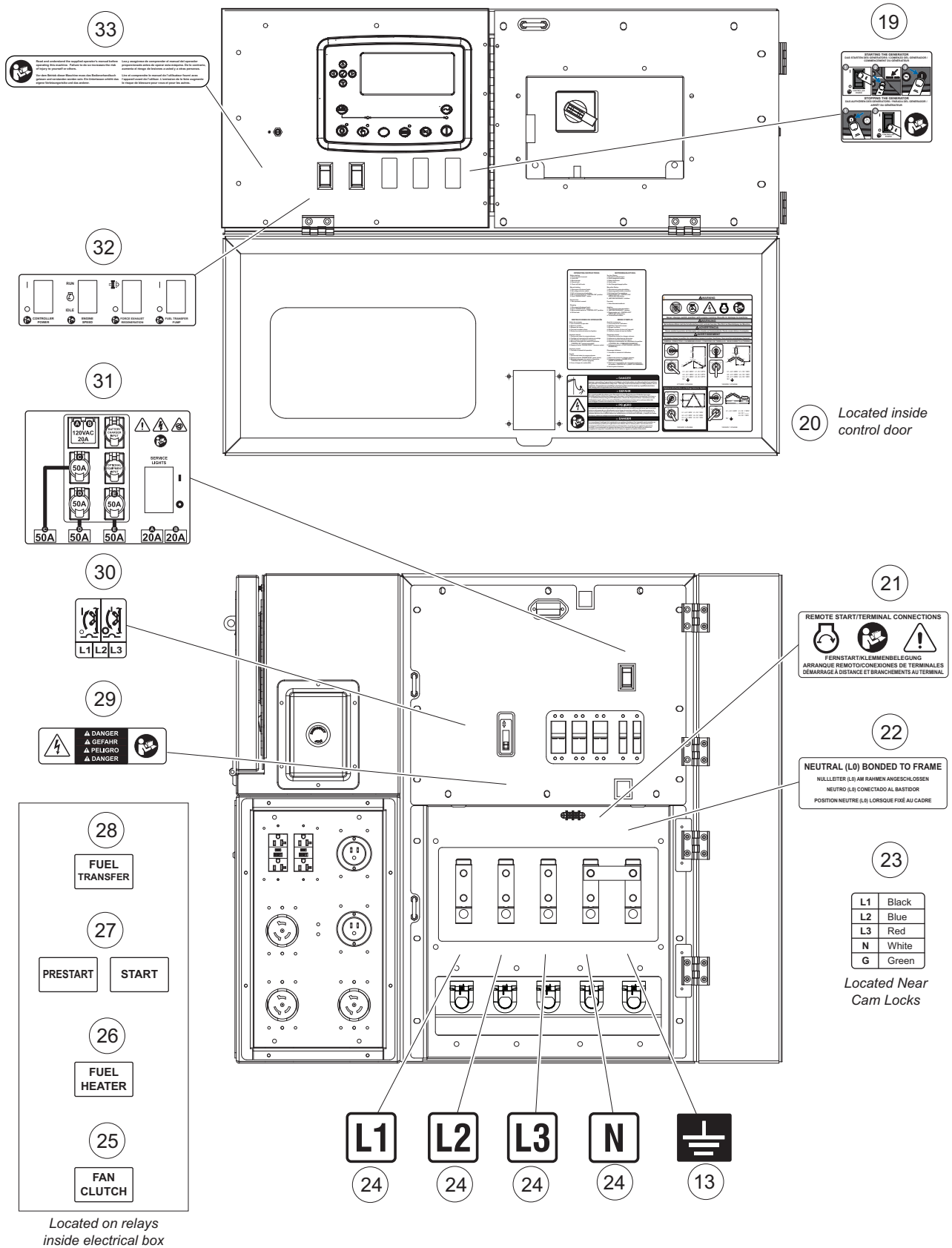

Figure 1-6. Control Panel Decals

Section 2: General Information

Specifications

Description	Unit of Measure	MMG25IF4	MMG35DF4
Engine			
Make	—	Isuzu®	John Deere®
EPA Tier	—	F4	F4
Fuel consumption—100%: Prime	gph (Lph)	2.1 (7.8)	2.9 (11.0)
Battery—Voltage (Qty of Batteries)	VDC (qty)	12 (1)	12 (1)
Battery—Rating	CCA	720	720
Generator			
Three phase—standby	kW (kVA)	26 (32)	31 (39)
Amps—Three phase—standby	480 V (208 V)	38 (89)	47 (108)
Three phase—prime	kW (kVA)	23 (29)	29 (36)
Amps—three phase—prime	480 V (208 V)	35 (80)	43 (100)
Single phase—standby	kW (kVA)	24 (24)	30 (30)
Amps—single phase—standby	240 V	100	125
Single phase—prime	kW (kVA)	22 (22)	27 (27)
Amps—single phase—prime	240 V	92	113
Frequency	Hz	60	60
Weights			
Dry weight—skid mounted	lb (kg)	2,430 (1,102)	3,125 (1,418)
Operating weight—skid mounted	lb (kg)	3,160 (1,433)	3,860 (1,751)
Dry weight—trailer mounted	lb (kg)	2,950 (1,338)	3,725 (1,690)
Operating weight—trailer mounted	lb (kg)	3,680 (1,669)	4,460 (2,023)
Capacities			
Usable fuel	gal (L)	90 (341)	90 (341)
Coolant system	qt (L)	18 (17)	18 (17)
Oil	qt (L)	11 (10.4)	11 (10.4)
Maximum run time	hr	42.9	31
AC Distribution			
Circuit breaker size	A	125	125

Specifications are subject to change without notice.

Description	Unit of Measure	MMG45IF4	MMG55DF4
Engine			
Make	—	Isuzu	John Deere
EPA Tier	—	F4	F4
Fuel consumption—100%: Prime	gph (Lph)	3.3 (12.5)	3.9 (14.8)
Battery—Voltage (Qty of Batteries)	V (quantity per unit)	12 (1)	12 (1)
Battery—Rating	CCA	720	720
Generator			
Three phase—standby	kW (kVA)	44 (55)	48 (60)
Amps—Three phase—standby	480 V (208 V)	66 (153)	72 (167)
Three phase—prime	kW (kVA)	38 (47)	44 (55)
Amps—three phase—prime	480 V (208 V)	57 (130)	66 (153)
Single phase—standby	kW (kVA)	40 (40)	46 (46)
Amps—single phase—standby	240 V	167	192
Single phase—prime	kW (kVA)	33 (33)	42 (42)
Amps—single phase—prime	240 V	138	175
Frequency	Hz	60	60
Weights			
Dry weight—skid mounted	lb (kg)	2,843 (1,290)	3,305 (1,499)
Operating weight—skid mounted	lb (kg)	3,580 (1,624)	4,040 (1,833)
Dry weight—trailer mounted	lb (kg)	3,363 (1,525)	3,905 (1,771)
Operating weight—trailer mounted	lb (kg)	4,100 (1,860)	4,640 (2,105)
Capacities			
Usable fuel	gal (L)	90 (341)	90 (341)
Coolant system	gal (L)	18 (17)	18 (17)
Oil	qt (L)	12 (11.4)	12 (11.4)
Maximum run time	hr	27	23
AC Distribution			
Circuit breaker size	A	225	225

Specifications are subject to change without notice.

Unit Dimensions

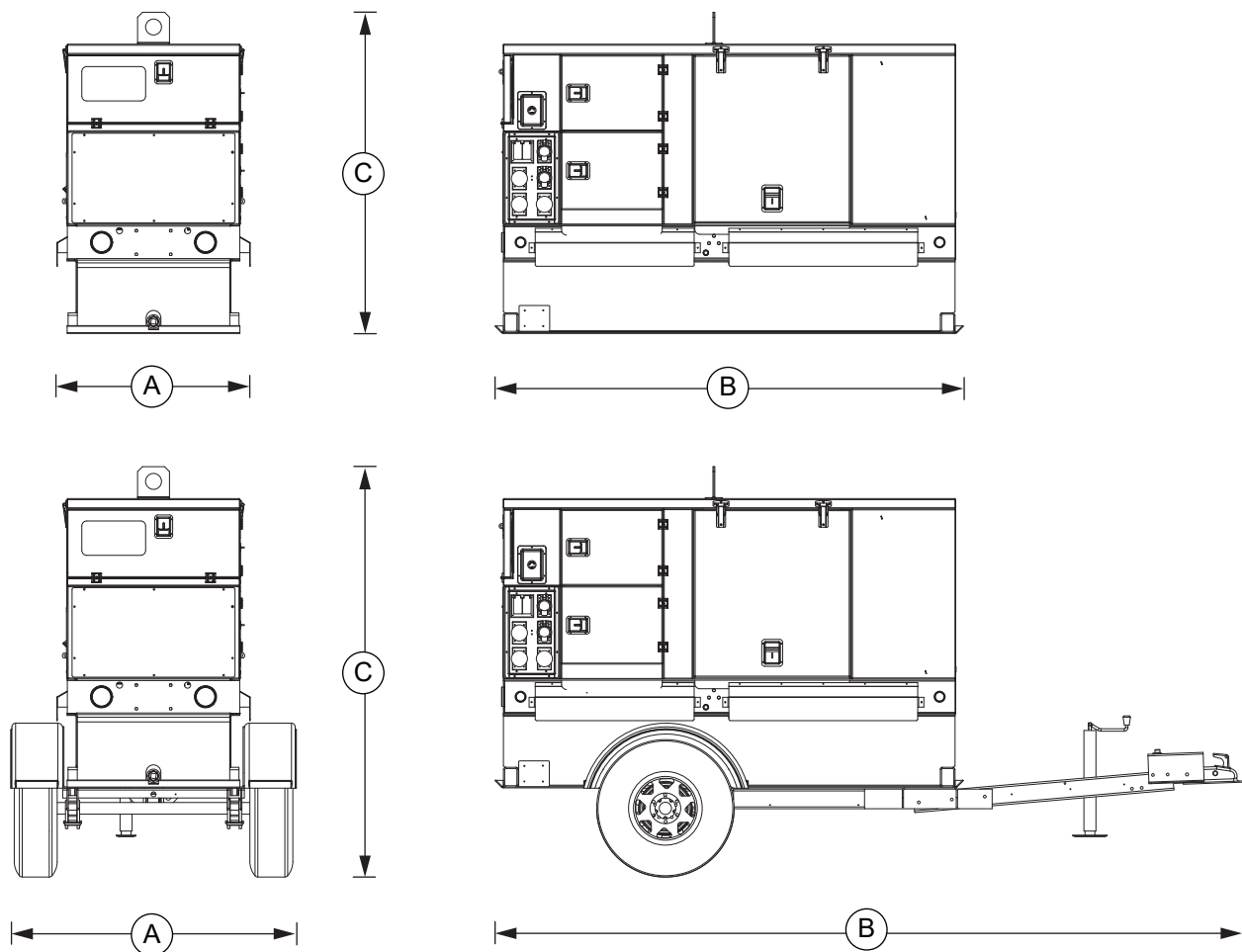

008083

Figure 2-1. Unit Dimensions

	L	W	H
Skid Mounted	39 in (0.99 m)	95 in (2.41 m)	65 in (1.65 m)
Trailer Mounted	58 in (1.45 m)	152 in (3.81 m)	83 in (2.11 m)

Unit and Serial Number Locations

See [Figure 2-2](#) to locate the unit ID tag (A) (located behind breaker door beneath breakers) and vehicle identification number (VIN) tag (B). Important information such as the unit model number, serial number, VIN, and tire loading information are listed on these tags. Record the information from these tags in the event the tags are lost or damaged. This information may be needed when ordering parts or requesting assistance.

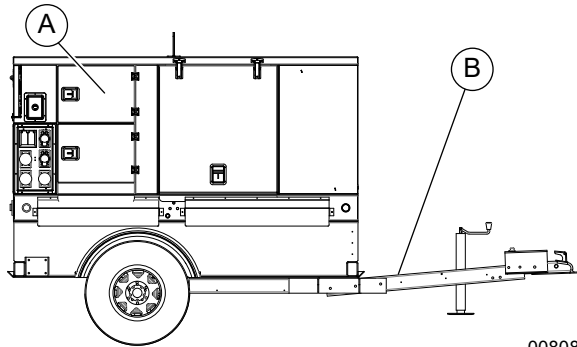

008083

Figure 2-2. Unit and Serial Number Locations

Altitude and Temperature Limitations

All units are subject to derating for altitude and temperature; this will reduce the available power for operating tools and accessories connected to the outlets. Typical reductions in performance are 0.5% for every 1,000 ft (305 m) and 2–4% for every 1,000 ft (305 m) above 10,000 ft (3,048 m) of elevation, and 1% per 10 °F (5.6 °C) increase in ambient air temperature over 72 °F (22 °C).

Component Locations

Exterior

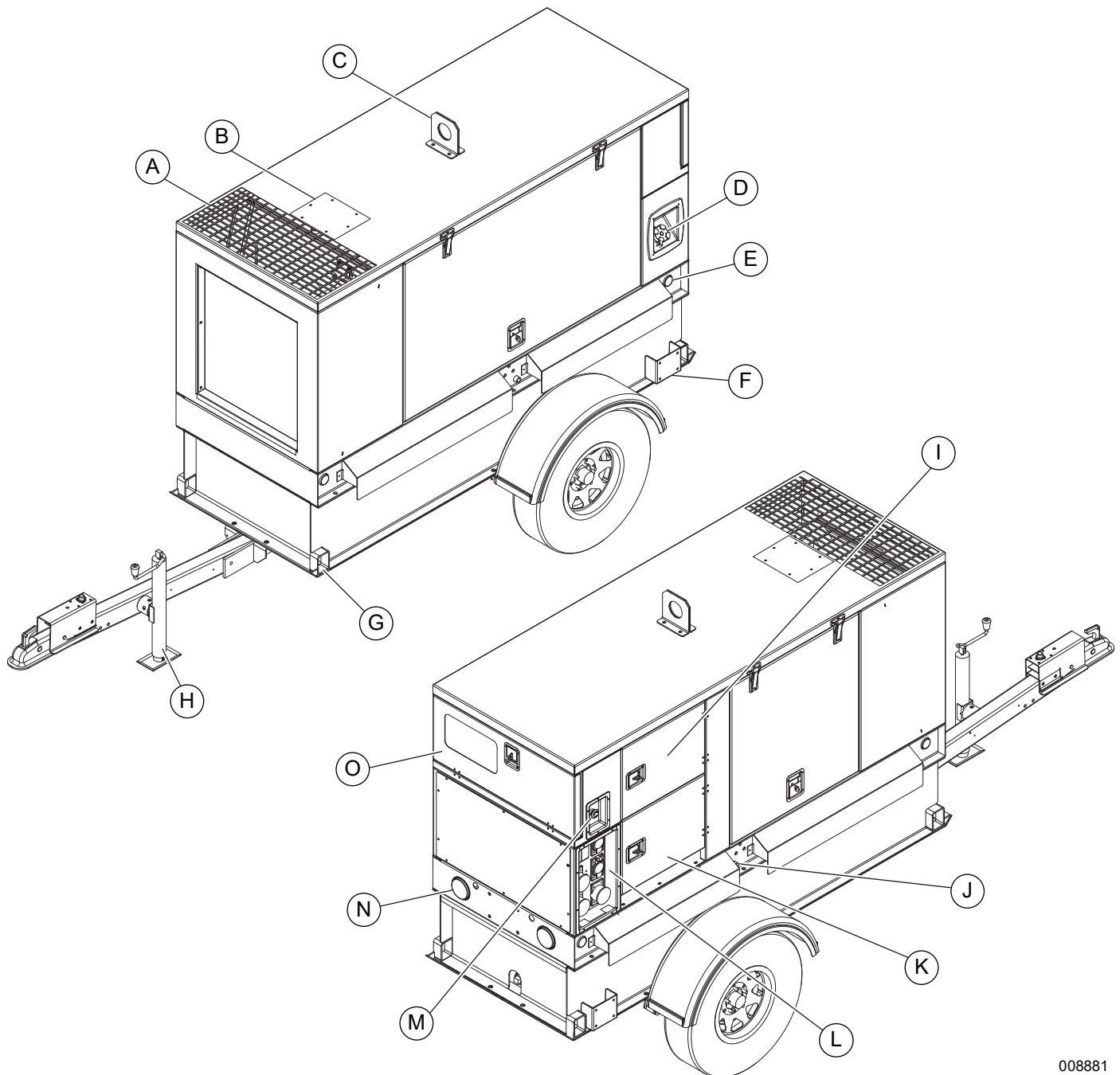

008881

Figure 2-3. Exterior Components

- | | |
|--------------------------------|------------------------------------|
| A Engine exhaust | I Breaker panel access door |
| B Radiator access panel | J Coolant and oil drain |
| C Unit lift point | K Lug box access door |
| D Fuel fill port | L Receptacle panel |
| E Side marker | M Emergency stop switch |
| F Rear stabilizer mount | N Tail light (2 locations) |
| G Tie-down point | O Control panel access door |
| H Tongue jack | |

Connection Panel

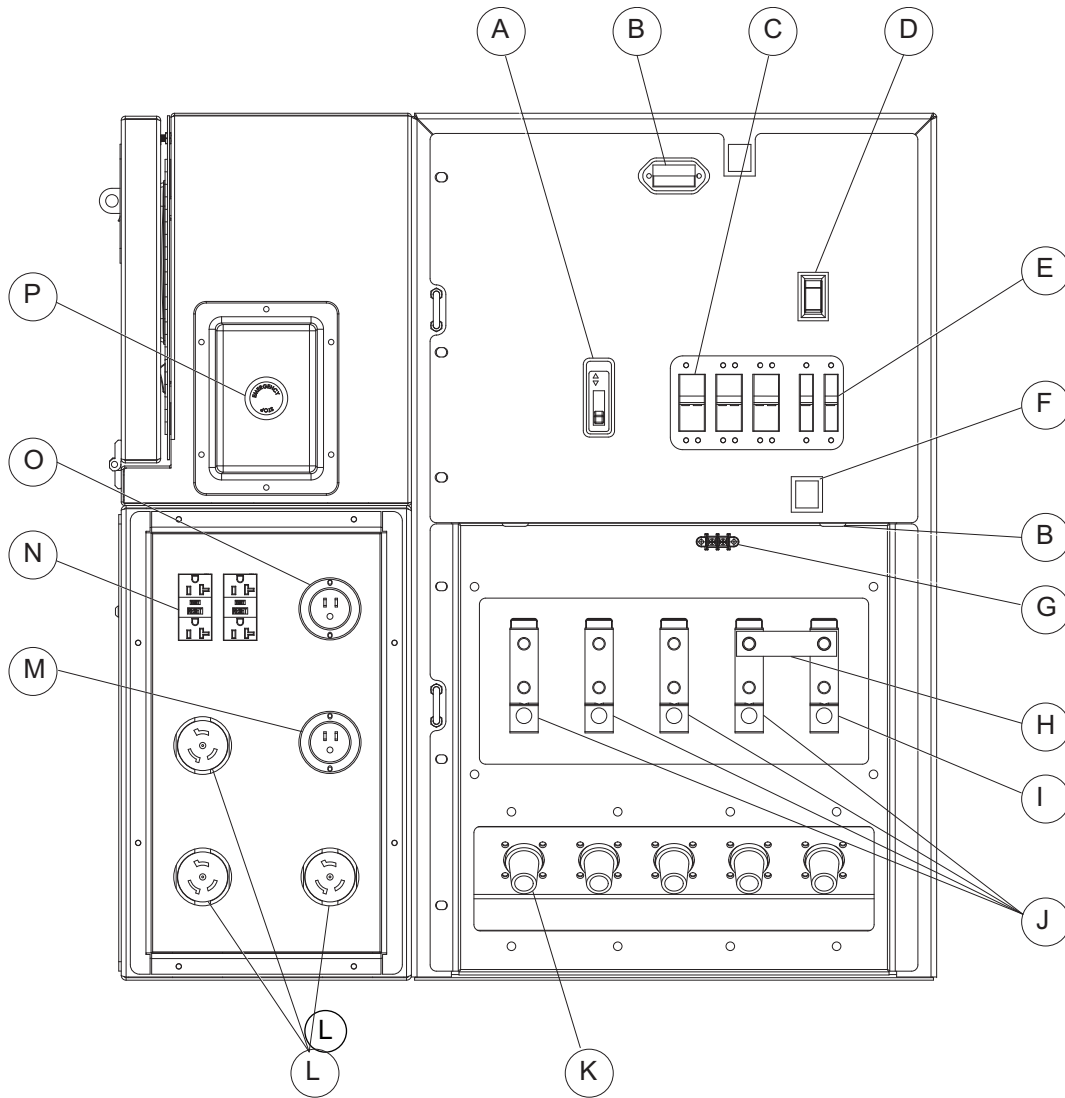

Figure 2-4. Connection Panel Components

- | | |
|---|--|
| A Main circuit breaker | I Ground connection lug |
| B Panel light | J Connection lugs |
| C 50 A circuit breaker (3 locations) | K Cam lock receptacle (5 locations) (if equipped) |
| D Service lights switch | L 120/240 V twist-lock outlets |
| E 20 A circuit breaker (2 locations) | M Connection for optional equipment Inlet |
| F Lug door safety switch | N 120 V GFCI outlet (2 locations) |
| G Remote start terminal block | O Connection for battery charger (if equipped) |
| H Neutral grounding bar | P Emergency stop switch |

Control Panel

Figure 2-5. Control Panel Components

- A** DSE 7310 MKII controller
- B** Potentiometer
- C** Control power switch

- D** Engine idle
- E** Voltage selector switch

Genset Controller

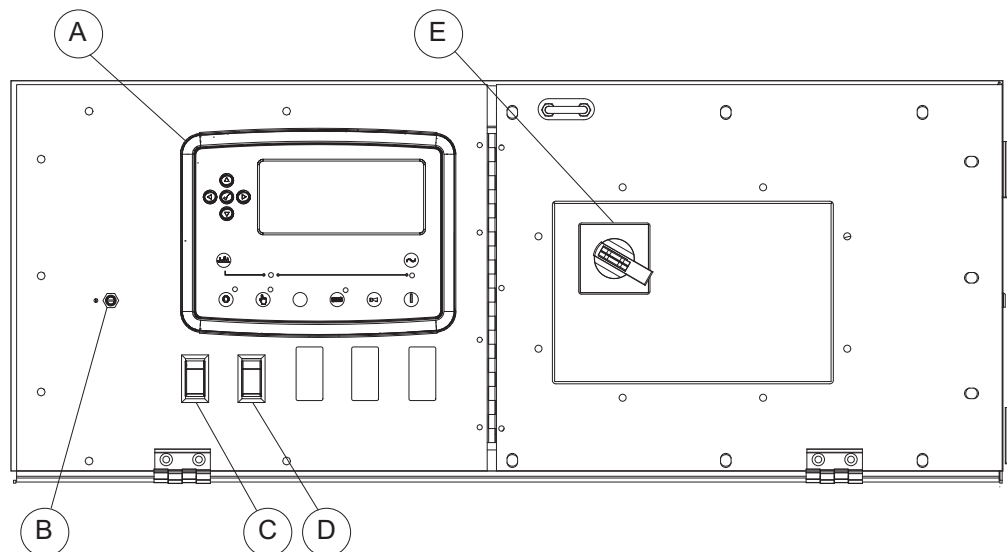
See [Figure 2-6](#). The genset controller displays real-time operational data, monitors functions of the generator and engine, shuts down the unit for certain fault conditions, displays fault data, and retains up to 250 unit performance events.

The controller is programmable. It can automatically start and stop the genset according to schedule, fault condition, or load demand.

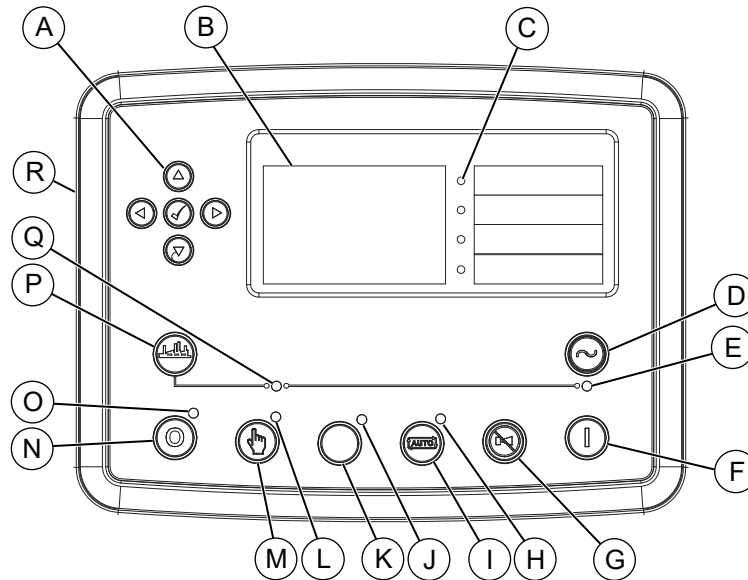

010417

Figure 2-6. Genset Controller—Deep Sea® Model DSE7310 MKII

TABLE 1.

A Navigation buttons	J Positive air shutoff (PAS) valve test switch LED (if equipped)
B Screen	K PAS valve test switch (if equipped)
C Indicator LED (4 locations)	L MANUAL Mode LED
D Transfer to Generator button	M MANUAL Mode button
E Generator Available LED	N Engine STOP/RESET Mode button
F Engine START button	O Engine STOP/RESET Mode LED
G Alarm Mute and Lamp Test button	P Open Generator button
H AUTO Mode LED	Q Open Generator LED
I AUTO Mode button	R RS232 serial port (not shown—controller backside)

(A) Navigation Buttons

See [Figure 2-7](#). Used to navigate the operator pages.

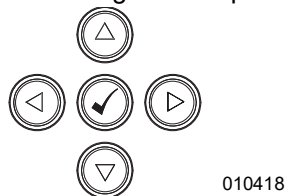

Figure 2-7. Navigation Buttons

Navigate the operator pages as follows.

TABLE 2.

- ▶ View next
- ◀ View previous
- ▲ Scroll up current
- ▼ Scroll down current
- ✓ Select highlighted item

(B) Controller Screen

The controller screen displays various operational data for unit monitoring, diagnosing, and troubleshooting. See [Operator Pages](#) for more information.

(C) Indicator LEDs

See [Figure 2-8](#). Each LED indicates a condition that impedes normal unit function.

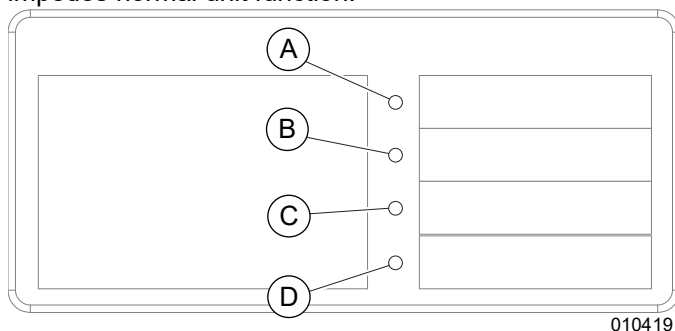

Figure 2-8. Indicator LEDs

If an indicator LED is illuminated, resolve the condition to restore normal unit function, as described in table below.

NOTE: When a condition is resolved, the corresponding

indicator LED switches off.

TABLE 3.

- A *Low Load* indicator LED.
 - Indicates genset has operated at less than 30% capacity for more than 15 minutes.
 - Resolve by increasing electrical load. If unable to operate genset at more than 30% load, use a smaller generator.
- B *Lug Door Open* indicator LED.
 - Indicates lug-box door is open.
 - Resolve by closing lug-box door. If condition remains unresolved, inspect lug-box door safety switch for proper operation.
- C *Emergency Stop* indicator LED.
 - Indicates Emergency Stop switch is active (pushed in).
 - Resolve by deactivating (pulling out) Emergency Stop switch.
- D *Shutdown* indicator LED.
 - Indicates a shutdown alarm is present.
 - Resolve by resolving shutdown condition.

NOTE: If unable to resolve a condition as recommended, contact a GMASD.

(D) Transfer to Generator Button

Only applies to MANUAL mode.

Controls operation of generator load switch, when the generator is available.

NOTE: In units equipped with a manual breaker, this function is not available.

Status is indicated by the Close Generator LED.

(E) Close Generator LED

- When illuminated, cam locks and lugs are enabled.
- When not illuminated, cam locks and lugs are disabled.

(F) Engine Start Button

When STOP/RESET mode is active, the Engine Start button switches on the engine ECU but does not start the engine. Uses in this context are to check status of the CAN communication and to prime the engine.

When MANUAL mode is active, the Engine Start button starts the generator.

NOTE: In AUTO or STOP mode, the Engine Start button activates the ECU.

(G) Alarm Mute and Lamp Test Button

Stops the audible alarm and illuminates functional controller LEDs.

To test the LEDs, press and hold button. All LEDs

illuminate. When button is released, the LEDs switch off.

NOTE: If an LED does not illuminate when button is pushed, the LED is not functioning.

(H) AUTO Mode LED

- When illuminated, AUTO mode is active.
- When not illuminated, AUTO mode is not active.

(I) AUTO Mode Button

Switches the mode to AUTO. See [Controller Modes](#) for important guidelines.

Status is indicated by the AUTO Mode LED.

(J) PAS valve test switch LED (if equipped)

When illuminated, PAS test is in progress.

(K) PAS valve test switch (if equipped)

When PAS test is active, the PAS is cycled to verify function.

(L) MANUAL Mode LED

- When illuminated, MANUAL mode is active.
- When not illuminated, MANUAL mode is not active.

(M) MANUAL Mode Button

Switches the mode to MANUAL. See [Controller Modes](#) for important guidelines.

Status is indicated by the MANUAL Mode LED.

(N) Engine STOP/RESET Mode Button

Switches the mode to STOP. See [Controller Modes](#) for important guidelines.

Status is indicated by the STOP/RESET Mode LED.

(O) Engine STOP/RESET Mode LED

- When illuminated, STOP mode is active.
- When not illuminated, STOP mode is not active.

(P) Open Generator Button

The Open Generator button is only active in the Manual Mode and allows the operator to open the generator load switch when a motorized breaker is used. Pressing the Open Generator button when the Generator is on load, the generator load switch is opened.

NOTE: In units equipped with a manual breaker, either limited or no function is available.

Status is indicated by the Open Generator LED.

(Q) Open Generator LED

- When illuminated, cam locks and lugs are disabled.
- When not illuminated, cam locks and lugs are enabled.

Controller Modes

MANUAL Mode

MANUAL mode is distinguished by full operator control of unit start-up and shut-down functions, and by full operator control of generator load and unload functions.

AUTO Mode

AUTO mode is distinguished by automation of unit start-up and shut-down functions, and by automation of generator load and unload functions.

AUTO mode utilizes the remote start connections. For remote starting procedures, see [Section 3, Operation](#).

AUTO mode utilizes a programmed schedule, which can be modified.

NOTE: To modify the AUTO mode programmed schedule, use the Deep Sea Configuration Suite software.

STOP/RESET Mode

STOP/RESET mode is distinguished by the following:

- Unloads the generator.
- Clears active alarms—if alarm conditions have been resolved.
- Shuts down the unit.
- Deactivates the Engine Start button.
- Stops all AUTO mode automation (if applicable).
- Controller power remains ON.

Switching Mode

7. Verify controller is ON.

NOTE: The engine can be running but it is not required.

8. Stop drawing power from the unit: Stop using equipment plugged into receptacles, cam locks, and anything connected to the lugs.
9. See [Figure 2-6](#). Press the desired Mode button. The mode immediately changes.

Operator Pages

Operator pages display various data for unit monitoring, diagnosing, and troubleshooting. The pages are:

- Status page
- Engine page
- Generator page
- Alarm page
- ECU DTC page
- Event Log page
- Serial Port page
- Program File Information page
- About page

NOTE: Operator pages are available after normal unit

start-up.

NOTE: Operator pages are view-only. No settings can be added, modified, or deleted.

Generator Page

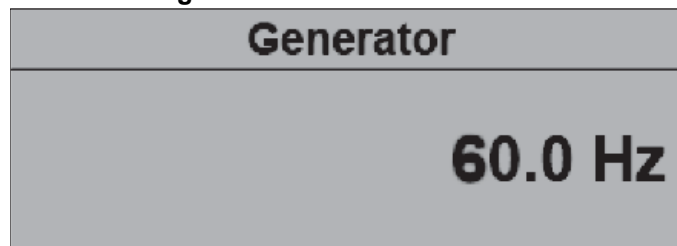

010422

Figure 2-9. Generator Page

The Generator page displays the following generator data, in real time (press ▲ or ▼ to scroll).

- Voltage (ph-N)
- Voltage (ph-ph)
- Frequency
- Current (A)
- Load ph-N (kW)
- Total load (kW)
- Load ph-N (kVA)
- Total load (kVA)
- Single phase power factors
- Power factor average
- Load ph-N (kvar)
- Total load (kvar)
- Accumulated load (kWh, kVAh, kvarh)
- Loading scheme
- Phase rotation
- Nominal
- Active configuration

NOTE: The list above varies, according to generator make, model, and features.

NOTE: As possible, distribute electrical loads equally among generator lines. Minor load imbalances (10% or less) usually do not cause problems. When loading generator, observe the load (amperage) on each line.

Alarms Page

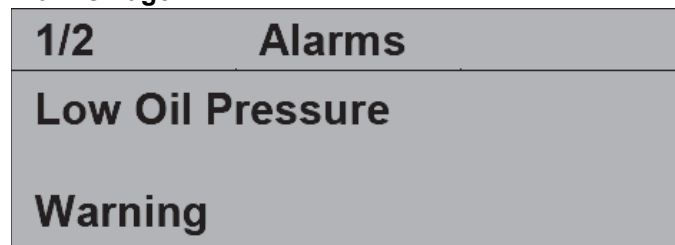

010423

Figure 2-10. Alarm Page

The Alarms page displays active warnings and active alarms, including engine DTCs.

ECU DTC Page

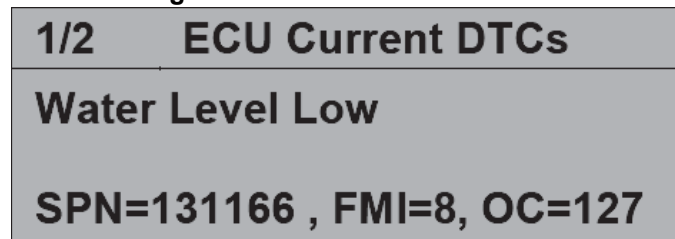

010424

Figure 2-11. ECU DTC Page—Current DTCs

The ECU Current DTC page displays active ECU DTCs. Press ► to view previous ECU DTCs.

NOTE: See engine manual for information on ECU DTCs.

NOTE: All DTCs display on the ECU DTC page. Some DTCs may also display in the Event Log, with similar descriptions as those displayed on the ECU DTC page.

Event Log Page

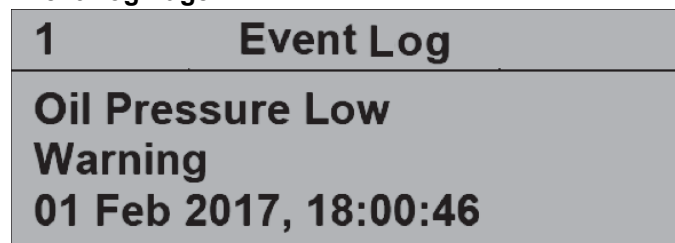

010425

Figure 2-12. Event Log Page

The Event Log page displays current and previous alarms.

- Event Log capacity is 250 alarm events. After 250 events are logged, each new event overwrites the oldest.
- Only alarms are logged.
- Newest event displays at top of log; oldest at bottom.

Serial Port Page

The Serial Port page displays information about the RS232 serial port, which enables data transfers. If an external modem is connected to the serial port, modem information also displays.

NOTE: The Serial Port page display may vary, in accordance with controller configuration.

See [Figure 2-13](#). If a modem is connected to the controller, *Modem* displays, as illustrated.

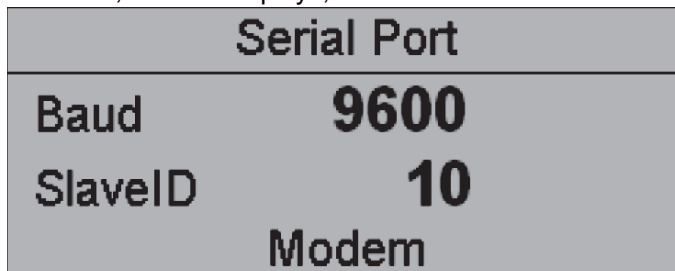

010426

Figure 2-13. Serial Port Page. If modem is not connected, RS232 displays in place of Modem.

See [Figure 2-14](#). When the controller can accept a data transfer, *Modem Ready* displays, as illustrated.

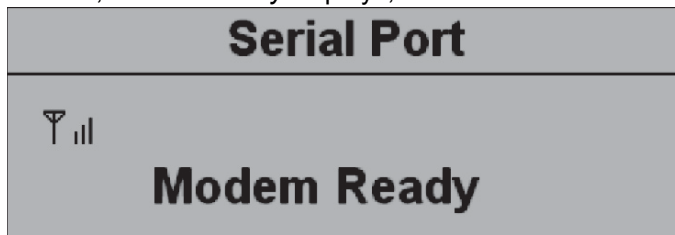

010427

Figure 2-14. Serial Port Page—Modem Ready

Program File Information Page

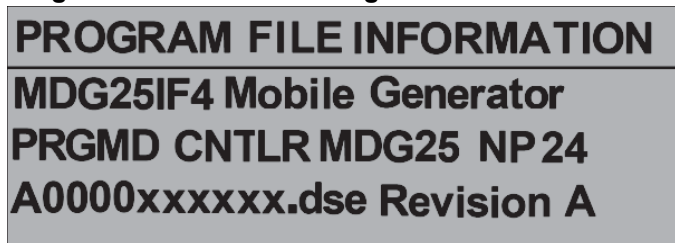

010428

Figure 2-15. Program File Information Page

The Program File Information page displays the following controller information.

- Controller model unit
- Program file name
- Program PN
- Program version

About Page

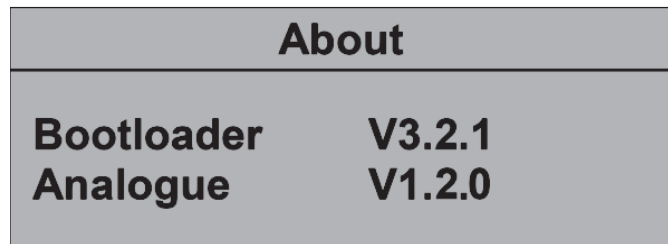
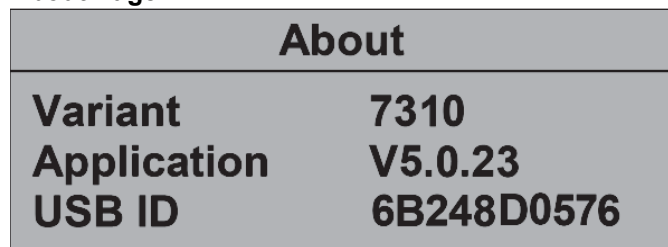

010429

Figure 2-16. About Page

The About page displays various general information about the unit and controller, as illustrated.

Maintenance Alarms

Maintenance alarms indicate a regular-maintenance service interval is expired. To resolve the condition, perform the indicated service, then re-set the corresponding service interval.

To re-set a service interval:

1. Display the Engine page.
2. Scroll (▲ or ▼) until the appropriate service interval is highlighted.

NOTE: The expired interval displays on the Alarm page.

3. Press and hold the Engine STOP/RESET Mode button until **###* hr service** changes to **0 hr service**.

**A number displays. The value varies according to what service interval is highlighted.*

Generator Monitoring

Generator information is displayed on both the generator button screen and generator tab within the [Maintenance Screens](#). See [Generator Tab](#).

Engine Monitoring

Engine information is displayed on both the engine operator screen and engine tab within the [Maintenance](#)

Screens. See [Engine Tab](#).

Controller Information Displays, Functions, and Reset

The controller constantly monitors vital generator and engine functions for a number of operation, alarm, and fault conditions. When a fault condition occurs, the engine shuts down automatically and the main display shows the fault that caused the shutdown. The fault condition must be resolved to resume operation. Press the ENTER (✓) button to reset the controller and resume operation.

Voltage Selector Switch



WARNING

Electric Shock. Never change the voltage selector switch while the engine is running or the controller is on. Doing so could result in death, serious injury or equipment damage.

(000302)

The voltage selector switch mechanically configures the main windings of the generator to provide a Hi Wye, Low Wye, Zig Zag, or Delta configuration providing single and three phase voltage output to the main breaker. Voltage ranges are selected by rotating the handle on the switch to the desired voltage.

The voltage selector switch is equipped with a lockout mechanism to prevent unauthorized changing of the voltage setting by locking the handle in place.

See [Using the Voltage Selector Switch](#) for instructions on switching the voltage.

Section 3: Operation

Pre-start Checklist

All items in the pre-start checklist must be completed before starting the unit. This checklist applies to both manual and remote starting of the unit.



Consult Manual. Read and understand manual completely before using product. Failure to completely understand manual and product could result in death or serious injury. (000100a)



Equipment damage. Do not attempt to start or operate a unit in need of repair or scheduled maintenance. Doing so could result in serious injury, death, or equipment failure or damage. (000291)



Risk of Fire. Unit must be positioned in a manner that prevents combustible material accumulation underneath. Failure to do so could result in death or serious injury. (000147)

- Verify all maintenance procedures are up to date. For more information, see [General Maintenance](#) and [Basic Maintenance Schedule](#).
- Verify the unit is level.
- Verify there is no water inside, on, or near the unit; dry if needed.
- For grounding requirements, follow any local, state, or National Electrical Code (NEC) guidelines.
- Verify the control power switch is OFF (O).
- Verify all circuit breakers are OFF (O).
- Inspect all electrical cords; repair or replace any that are cut, worn, or bare.
- Verify oil, coolant, and fuel levels are correct, per the engine manufacturer's manual.
- Verify battery connections are secure.
- Turn the battery disconnect switch ON (if equipped).
- Verify engine fan belt tension and condition are within spec.
- Verify engine fan belt guard is installed and secure.
- Check engine exhaust system for loose or rusted components.
- Verify the radiator and surrounding shroud are clear of debris.
- Verify all covers are in place and secure.

- Verify all electrical connections at the connection lugs, if equipped, are tight and wired correctly.
- Verify the voltage selector switch is set to the desired voltage and locked.
- Verify the emergency stop switch is pulled out.
- Verify all doors on the unit are closed.

Manually Starting the Unit



Asphyxiation. Running engines produce carbon monoxide, a colorless, odorless, poisonous gas. Carbon monoxide, if not avoided, will result in death or serious injury. (000103)



Fire risk. Fuel and vapors are extremely flammable. Do not operate indoors. Doing so could result in death, serious injury, or property or equipment damage. (000281)

All units equipped with the Power Zone controller will initially start up in STOP mode. Proceed as follows to start the generator in MANUAL mode:

1. Set the control power switch to ON (I).
2. The display screen will show the pre-start diagnosis, and the controller will load the unit management software.

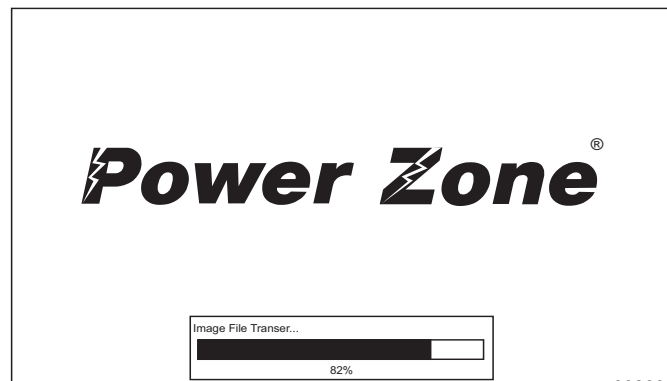
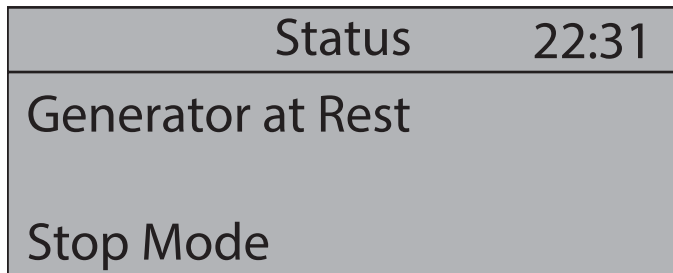

Figure 3-1. Pre-start Screen

3. The home screen will be displayed when the software is loaded, and the controller will be in STOP mode as indicated at the top of the screen. Press the AUTO or MANUAL mode (🔑) button to enter MANUAL mode.



002805

Figure 3-2. Home Screen

NOTE: The controller can be started from any screen when it is in MANUAL mode.

- Pressing the green engine START (I) button on the controller will initiate the startup procedure and start the engine, if there are no engine faults preventing the unit from starting.

NOTE: It may take a few seconds for the engine to run smoothly and reach its governed operating speed. During this time, the screen will show a voltage different from the voltage set with the voltage selector switch.

- If the engine does not start after the first cranking attempt, the engine will pause for 15 seconds to allow the starter to cool. The display screen will show MANUAL MODE - CRANK REST at the top of the screen. The engine will make two more attempts to start for a total of three crank cycles.
- If the engine does not start and run within three crank cycles, the display screen will show the fail to start alarm. The starting sequence can be repeated after the starter has had a minimum of two minutes to cool. Pressing the ENTER (✓) button will clear the alarm and reset the controller.

NOTE: The engine controller may skip the preheat engine steps on some of the larger models.

- Once the engine starts, it begins speeding up to a constant 1,800 rpm. The engine may hunt or change speeds until operating speed is reached. The engine will be warmed up and the operator screens will show engine and generator operating parameters after a few minutes of operation.
- Check the generator for excessive noise or vibration and any coolant, oil, or fuel leaks before applying any loads.
- Verify the AC output voltage is correct. See [Fine Tuning the Voltage](#).
- Verify the frequency (Hz) is correct on the generator screen. The frequency should read approximately 60 Hz with no loads connected to

the generator, depending on the type of engine governing used.

- If all wiring connections have been made correctly, switch the main circuit breaker to ON (I), and then add any loads attached to the receptacles by switching the respective circuit breaker to the ON (I) position. A slight change in engine sound when a load is applied to the unit is normal.

AUTO (Remote) Starting the Unit

AUTO mode is used when the unit is started from a location other than the control panel by using a transfer switch. AUTO (remote start) is the normal setting when the unit is being used as a standby power supply. Review the [Pre-start Checklist](#) and [Manually Starting the Unit](#) before putting the unit in AUTO mode. Follow all safety warnings and review all information on isolating the generator with a transfer switch if the unit is to be used as a standby power supply. See [AUTO Exercise Timer](#), then proceed as follows:

- Perform a manual start of the unit at least once to verify the engine is operating correctly.
- To check the remote start circuit, remove the wires from the remote start terminal block. Press the AUTO or MANUAL mode (⏻) button, and the display screen will show auto mode at the top of the screen.
- Attach a jumper wire (minimum 16 gauge) across the two terminals on the remote start terminal block. This applies a ground to the Power Zone controller to close the starting circuit contacts. The engine will crank, start, and run.
- Remove the jumper wire from the remote start terminal block and the engine will stop. Reconnect any necessary wires from the remote start switch (transfer switch) to the remote start terminal block.
- Verify the unit is in AUTO mode. The display screen should show AUTO mode at the top of the screen.
- Switch the main circuit breaker ON (I).
- Secure the unit by closing and locking all access doors.
- The unit is now ready for remote starting.

See [Figure 3-3](#). The remote start terminal block provides a connection for installation of a remote start switch which will allow the unit to be started by a remote dry-contact closure switch. For location of the remote start terminal block, see [Figure 2-4](#).

Before entering AUTO mode, verify the contacts on any remote switch linked to the unit are open. If the contacts on a remote switch are closed, the engine will crank and start when AUTO mode is entered. Attach the switch leads to the two unused terminals (A) on the unit's remote start terminal block.

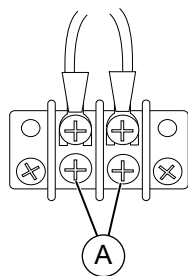

002806

Figure 3-3. Remote Start Terminal Block

Wet Stacking

The unit is powered by a diesel engine. Diesel engines are susceptible to wet stacking if lightly loaded. Wet stacking occurs when an engine is run at less than 30% of its full load capacity, causing unburned fuel to accumulate in the exhaust system. Wet stacking can be detected by continuous black exhaust when the unit is under a constant load. It can also cause fouling of injectors and buildup on engine valves. Diesel engines operate properly when applied loads are between 30% and 100% capacity. Appropriate generator sizing is determined by the anticipated load. If the unit is in a wet stack condition, load the unit heavily for five hours or until the exhaust is clear.

Cold Weather Features (if equipped)

The engine may be equipped with optional equipment, such as a coolant heater, oil pan heater, crankcase ventilation heater, battery heater or fuel heater as cold weather starting aids.

See [Figure 3-4](#). Starting aids are required below 32 °F (0 °C). They will enhance starting performance below these temperatures and may be needed to start applications that have high parasitic loads during cranking and start acceleration to idle. Other cold weather starting aids are required at temperatures below -13 °F (-25 °C) or at altitudes above 5,000 ft (1,500 m).

The use of correct grade oil (see [Engine Oil Recommendations](#)) is critical to achieving adequate cold weather cranking speed. Synthetic oils have improved flow at low temperatures.

The oil pan heater, battery heater and fuel filter heater (if equipped) are activated with a thermostat and will turn on and off as needed. The coolant heater is powered by a shore power 120 V electrical connection that can be found in the convenience receptacle. The crankcase ventilation heater is powered by the generator and will stay on when the engine is operating in cold weather conditions.

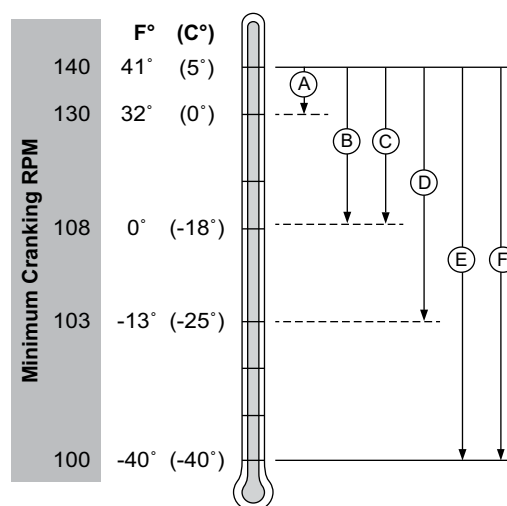

Figure 3-4. Cold Weather Starting Guidelines

A	No Aids
B	Block Heater 25l, 45l
C	CCV Heater 25l
D	Fuel Filter Heater 25l
E	Oil Heater 25l
F	60/40 Coolant 25l

Use cold weather starting aids as needed according to [Figure 3-4](#). Follow supplier instructions for starting aids provided on engine. A booster battery can be connected if needed (see [Using a Booster Battery or Charger \(if equipped\)](#)).

NOTE: Additional information on cold weather operation is available from your local GMASD.

Using a Booster Battery or Charger (if equipped)



WARNING

Explosion. Batteries emit explosive gases while charging. Keep fire and spark away. Wear protective gear when working with batteries. Failure to do so could result in death or serious injury.

(000137a)



WARNING

Risk of burns. Batteries contain sulfuric acid and can cause severe chemical burns. Wear protective gear when working with batteries. Failure to do so could result in death or serious injury.

(000138a)



CAUTION

Equipment damage. Do not make battery connections in reverse. Doing so will result in equipment damage.

(000167a)

See **Figure 3-6**. A 12-volt booster battery can be connected in parallel with unit batteries to aid in cold weather starting. ALWAYS use heavy-duty jumper cables.

Series:

- Amps = Same as single battery
- Volts = Twice as a single battery

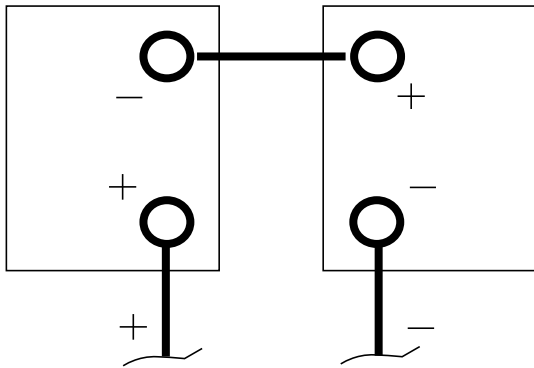

004507

Figure 3-5. Series

Parallel:

- Amps = Twice as a single battery
- Volts = Same as single battery

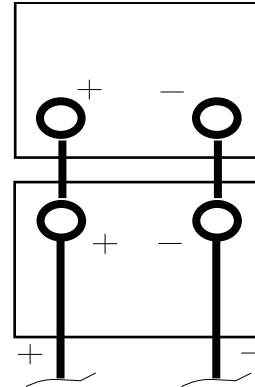

Figure 3-6. Parallel

004508

1. Connect booster battery or batteries to produce the required system voltage.

NOTE: To avoid sparks, do not allow the free ends of jumper cables to touch engine.

2. Connect one end of jumper cable to the POSITIVE (+) post of the booster battery.
3. Connect the other end of the jumper cable to the POSITIVE (+) post of battery connected to starter.
4. Connect one end of the other jumper cable to the NEGATIVE (-) post of the booster battery.
5. Complete the hookup by making the last connection of the NEGATIVE (-) cable to a good ground on the engine frame and away from the batteries.
6. Start the engine. Disconnect jumper cables immediately after engine starts. Always disconnect NEGATIVE (-) cable first.

Generator Output Connections

⚠ DANGER

Electrical backfeed. Use only approved switchgear to isolate generator from the normal power source. Failure to do so will result in death, serious injury, and equipment damage.

(000237)



⚠ DANGER

Electrocution. Do not disable or modify the connection box door safety switch. Doing so will result in death or serious injury.

(000157)



⚠ DANGER

Electrocution. Before connections are made to the unit, verify the main circuit breaker and battery disconnect switch are OFF. Failure to do so will result in death or serious injury.

(000156)

⚠ WARNING

Electric shock. Only a trained and licensed electrician should perform wiring and connections to unit. Failure to follow proper installation requirements could result in death, serious injury, and equipment or property damage.

(000155a)

The installation should be in compliance with the national electrical code (NEC), state, and local regulations.

See **Figure 3-7**. The unit is equipped with connection lugs (A), located on the lower portion of the control box behind the lug box door. The lugs provide connection points to attach external loads to the generator. A large decal on the inside of the connection lug door details the proper connections for selected voltages.

Connections to the lugs should be made by running the power cables up through the opening in the bottom of the box.

IMPORTANT NOTE: Do not make any connections directly to the lugs without routing the cables through the opening. Use a hex-wrench to tighten the cable connections.

The connection lug door is equipped with safety interlock switches that will trip the main circuit breaker and disable the voltage regulator if the door is opened while the unit is operating.

A ground connection (B) is located next to the connection lugs. The unit must be connected to ground for proper operating safety. The generator neutral is bonded to

ground when it is shipped from the factory. The bonding plate must be removed when the generator is used as a standby power source.

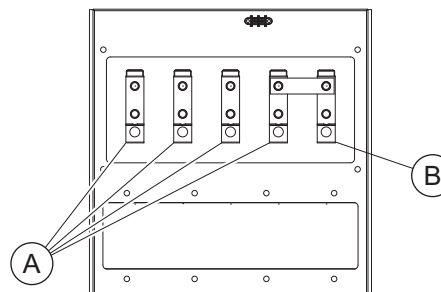

007618

Figure 3-7. Generator Connection Lugs

Generator Cam Lock Connections (If Equipped)



⚠ DANGER

Electrocution. Before connections are made to the unit, verify the main circuit breaker and battery disconnect switch are OFF. Failure to do so will result in death or serious injury.

(000156)

⚠ DANGER

Electrical backfeed. Use only approved switchgear to isolate generator from the normal power source. Failure to do so will result in death, serious injury, and equipment damage.

(000237)



⚠ WARNING

Electric Shock. Verify all connections to the cam lock receptacles are made to one side only. Failure to do so could result in death, serious injury and property damage.

(000308)

⚠ WARNING

Electric shock. Only a trained and licensed electrician should perform wiring and connections to unit. Failure to follow proper installation requirements could result in death, serious injury, and equipment or property damage.

(000155a)

See **Figure 3-8**. The unit may be equipped with cam lock connections (A) located below the receptacles. These receptacles provide connection points to attach external loads to the generator. A decal below the cam lock connections details the proper connections for selected voltages.

Connections should be made by plugging power cables equipped with series 16 taper nose 400A/600V cam lock

plugs into the cam lock receptacles. Secure the connection by rotating the plug ½ turn to the right.

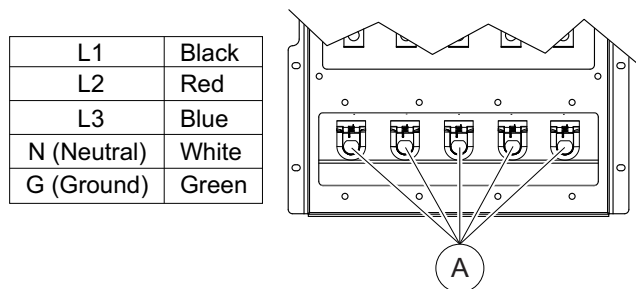

Figure 3-8. Cam Lock Connections

IMPORTANT NOTE: This procedure is only permitted on non-parallel capable machines. Machines set up with parallel controls will not respond to voltage adjustments when the breaker is closed.

See **Figure 3-9**. Use the controller navigation buttons to fine-tune generator output voltage.

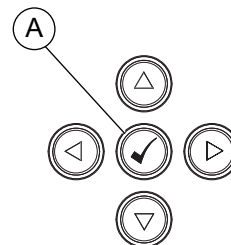

Figure 3-9. Navigation Buttons

010418



⚠ DANGER

Electrocution. Do not disable or modify the connection box door safety switch. Doing so will result in death or serious injury.

(000157)

A ground connection is located on the far right of the cam lock panel. The unit must be connected to a good earthen ground for proper operating safety. The generator neutral is bonded to ground when it is shipped from the factory. The bonding plate must be removed when the generator is used as a standby power source. Installation should be in compliance with the National Electrical Code (NEC), state, and local regulations.

Using the Voltage Selector Switch



⚠ WARNING

Electric Shock. Never change the voltage selector switch while the engine is running or the controller is on. Doing so could result in death, serious injury or equipment damage.

(000302)

1. Shut down the unit according to [Shutting Down the Unit](#).
2. Remove padlock from voltage selector switch lockout device.
3. Move voltage selector switch to desired voltage.
4. Replace and lock padlock on voltage selector switch lockout device.
5. Start the unit according to [Manually Starting the Unit](#) or [AUTO \(Remote\) Starting the Unit](#).

Fine Tuning the Voltage

Voltage adjustment range is ±10%. This can be done when engine is running and breaker is closed to fine tune voltage output at load connection.

1. From the Home page, press and hold the CHECK-MARK button (A) to access the Running configuration editor - display.
2. Press the UP or DOWN button to scroll to the Editor - Generator Voltage Adjust L-N page.
3. Press and release the CHECKMARK button so the voltage starts to flash.
4. Press the UP or DOWN button to change voltage.
5. Press and release the CHECKMARK button to set and save the voltage setting. The value stops flashing.

NOTE:

- The new voltage setting is retained through ON-OFF cycles of the generator.
 - When battery power is cycled through the battery disconnect switch, the voltage setting returns to the target voltage for which the link board is configured.
6. Press and hold the CHECKMARK button to exit the Running configuration editor.

Voltage Regulator

The automatic voltage regulator controls the output of the generator by regulating the current into the exciter field. The voltage regulator is adjusted before shipment from the factory. The regulator has four screwdriver adjustable potentiometers that may be adjusted for under frequency roll-off (U/F), U/F dip (DIP), stability (STAB), and voltage (VOLT). Contact a GMASD for additional information before attempting to adjust the voltage regulator.

NOTE: For units equipped with a Marathon DVR2000E+ automatic voltage regulator, see the Marathon operating manual provided with the unit.

Achieving 240V Three-Phase in 208V Three-Phase (Parallel Low Wye) Configuration



WARNING

Electric Shock. Never change the voltage selector switch while the engine is running or the controller is on. Doing so could result in death, serious injury or equipment damage.

(000302)

CAUTION

Equipment Damage. Verify voltage application before making changes to factory settings. Incorrect voltage applied to a load could result in equipment damage.

(000303)

IMPORTANT NOTE: Using this method to achieve 240V 3Φ will result in a line to neutral voltage of 139V, and is not recommended for single phase usage.

Proceed as follows to check which version of the Power Zone controller application the unit has:

1. With the unit shut down, set the control power switch to the ON (I) position. The controller will toggle automatically to the home screen after initialization.
2. Press ▲, ►, ▼, or ◀ to enter the maintenance screens.
3. Press ► until the status tab is selected. This tab will display which version of the Power Zone application the unit has.

NOTE: The version is also displayed in the top left corner of the Configuration menu. See [Accessing the Configuration Menu](#).

After verifying the unit has V4 or higher of the Power Zone controller application, proceed as follows to achieve 240V while in the 208V configuration:

4. Starting in any of the operator screens, press ▲, ►, ▼, or ◀ to enter the maintenance screens.
5. Press ✓ and O simultaneously. The next screen will display the configuration menu.
6. Press ▼ to move the cursor (blue highlighted text) down to Config Selection.
7. Press ► to highlight Config to Edit. Press ► again to highlight Selected Configuration. Then press ✓ to access the selections.
8. Press ▲ to highlight Alternative Configuration 1. Press ✓.
9. Press ◀ two times to get back to the far left column.
10. Press ▼ to highlight Password Entry. Press ✓ to display the Pin Entry screen. Press ✓ again to

access to password entry. The left most pound sign should change to 0.

11. Press ▲, ►, ▼, or ◀ to enter the password 4444 if applicable. Press ✓.
12. Press ▼ to highlight Generator. Press ► again to access the selections.
13. Press ▼ to highlight Generator Voltage. Press ► again to access the selections.
14. Press ▼ to highlight Over Voltage Alarms. Press ► again to access the selections.
15. Press ▼ to highlight Alarm Trip and press ✓ to adjust the voltage.

NOTE: Alarm trip setting must be changed first in order to set the pre-alarm trip setting.

16. Press ▲ until the voltage becomes 153V. Press ✓.
17. Press ▲ and ✓ to adjust the voltage for the Pre-alarm Trip.
18. Press ▲ until the voltage becomes 151V. Press ✓.

NOTE: It is recommended the current trip settings are also changed. The current values will depend on the unit.

19. Press ▲ and hold ✓ for five seconds until the saving screen appears. The screen will then return to the maintenance screens.

NOTE: Change the alarm settings back for the 208V configuration according to [Changing Back to 208V Configuration](#).

Changing Back to 208V Configuration

When finished with the 240V settings, change the alarm settings back for the 208V configuration. Follow steps 1-19 above, changing the Pre-alarm Trip to 132V and the Alarm Trip to 134V.

NOTE: Verify the pre-alarm trip setting is adjusted before the alarm trip setting in order to set the alarm trip setting

Customer Convenience Receptacles

CAUTION

Equipment Damage. Verify voltage application before making changes to factory settings. Incorrect voltage applied to a load could result in equipment damage.

(000303)

See [Figure 2-4](#). The unit is equipped with four receptacles. The 240/120V twist-lock receptacles are rated at 50A each. The 120V GFCI receptacles are rated at 20A each, with ground fault circuit interrupt (GFCI) protection. The receptacles are not routed through the main circuit breaker. Each receptacle has its own circuit breaker, located directly above or next to the receptacle. Each breaker is sized to the maximum rating of the corresponding receptacle.

NOTE: Power to the receptacles is available any time the generator is running, even if the main circuit breaker is OFF (O). Verify equipment connected to the receptacles is turned OFF before turning the breakers ON (I).

NOTE: When the voltage selector switch is in position for 480/277V three-phase, voltage at the two GFCI receptacles is 139 volts and the voltage at the three twist-lock receptacles is 240/139 volts. Generac Mobile does not recommend using the receptacles in the 480V position. When the voltage selector switch is in position for 208/120V three-phase, voltage at the two twist-lock receptacles and the two GFCI receptacles is 208/120 volts.

Main Circuit Breaker

The main circuit breaker is located on the main control panel. See [Figure 2-4](#). When the breaker is OFF (O), power is interrupted to the connection lugs, the optional cam lock receptacles, and the generator. The breaker may be switched ON (I) once the connections have been made to the connection lugs or the optional cam lock receptacles, and the unit has been started and allowed to reach normal operating temperature.

NOTE: Main circuit breaker can not be turned on until controller reads GENERATOR AVAILABLE.

Reasons the main circuit breaker may trip:

- Generator circuits to connection lugs or optional cam lock receptacles are overloaded.
- Door covering connection lugs or optional cam lock receptacles is open.
- Emergency stop switch is enabled.
- Idle switch on front of control panel is enabled.

Verify any problems that cause the main circuit breaker to trip are corrected before returning the switch to ON (I).

NOTE: The main circuit breaker only interrupts power to the connection lugs and the optional cam lock receptacles. The customer convenience receptacles have power even if the main circuit breaker is OFF (O). Use the individual circuit breakers located near each receptacle to disconnect power to these receptacles.

DOC and SCR Cleaning Operations



WARNING

Risk of Burn. Stay clear of the exhaust system during operation and exhaust filter cleaning. Exposure to hot exhaust gases and components could result in serious injury. (000304)

When enabled, the exhaust after-treatment system goes through an automatic cleaning process known as regeneration. Under normal circumstances, regeneration

occurs without interrupting unit operation and with minimal operator involvement. In the event there are conditions requiring the operation of the unit with the auto exhaust after-treatment cleaning disabled, the operator may be required to perform procedures to enable or disable the auto exhaust after-treatment cleaning. The operator may also be required to perform a manual regeneration.

NOTE: Always park the unit in a safe location for elevated exhaust temperatures and check for adequate fuel level before beginning the exhaust after-treatment cleaning process. The cleaning cycle can take an extended period of time (approximately 45 minutes). Cleaning is complete when the regeneration indicator remains off.

Disabling Automatic (AUTO) Exhaust After-Treatment Cleaning (If Equipped)

The auto exhaust after-treatment cleaning feature should always be enabled unless doing so would cause an unsafe working environment. In the event that an unsafe working environment occurs, proceed as follows to disable the auto exhaust after-treatment cleaning feature:

1. Locate the REGEN INHIBIT on the outside of the control panel under the display.
2. Set the switch to DISABLED (O).
3. Enter the SCR status screen and verify the disabled regeneration indicator appears above the words SCR INHIB - SOLID.

IMPORTANT NOTE: Disabling auto exhaust after-treatment cleaning is not recommended for any situation unless it is safety related or if the fuel tank lacks the required fuel to complete the cleaning process.

NOTE: If the soot level exceeds 100% contact Generac Mobile Technical Service at 1-800-926-9768 or www.generacmobileproducts.com.

Force a Manual Exhaust After-Treatment Cleaning

If running the unit with the exhaust after-treatment cleaning function disabled, the SCR status screen may display a red alarm, prompting the operator to force a manual exhaust after-treatment cleaning. Proceed as follows to force a manual exhaust after-treatment cleaning:

1. Locate the REGEN INHIBIT on the outside of the control panel under the display.
2. Set and hold the switch in ON/FORCED (I) for five seconds.
3. Enter the SCR status screen and verify the regeneration indicator appears above the words SCR LAMP - SOLID.

Enable Exhaust After-Treatment Cleaning

If the environment no longer requires the exhaust after-treatment cleaning function to be disabled, and there are no alarms present on the SCR status screen, the auto exhaust after-treatment cleaning function should be enabled. Proceed as follows to enable the auto exhaust after-treatment cleaning feature:

1. Locate the REGEN INHIBIT on the outside of the control panel under the display.
2. Set the switch to ON/AUTO (I/O).
3. Enter the SCR status screen and verify the re-generation indicator appears above the words SCR LAMP - SOLID.

Transfer Switch

⚠ DANGER

Loss of life. Property damage. Installation must always comply with applicable codes, standards, laws and regulations. Failure to do so will result in death or serious injury. (000190)

⚠ DANGER

Electrical backfeed. Use only approved switchgear to isolate generator from the normal power source. Failure to do so will result in death, serious injury, and equipment damage. (000237)

⚠ WARNING

Electric shock. Only a trained and licensed electrician should perform wiring and connections to unit. Failure to follow proper installation requirements could result in death, serious injury, and equipment or property damage. (000155a)



⚠ WARNING

Electric shock. Phase rotation must be compatible. Incompatible phase rotation could result in death, serious injury, or equipment damage. (000226b)

The installation should be in compliance with the National Electrical Code (NEC), state, and local regulations.

Before any connections are attempted, verify the main circuit breaker and the control power switch are in the OFF (O) position and that the negative (-) battery cable has been disconnected from the battery.

Installation of such devices must be performed by following all directions supplied by the manufacturer of the switch. If attaching the unit to a power supply normally serviced by a utility company, notify the utility company and check state and local regulations. Familiarize yourself with all instructions and warning labels supplied with the switch.

When the unit is used as a standby power supply, it must be equipped with a transfer switch that isolates it from the utility's distribution system. A transfer switch is designed to transfer electrical loads from the normal power source (utility) to the emergency power source (generator) when normal voltage falls below a prescribed level. The transfer switch automatically returns the load back to the normal source when power is restored back to operating levels.

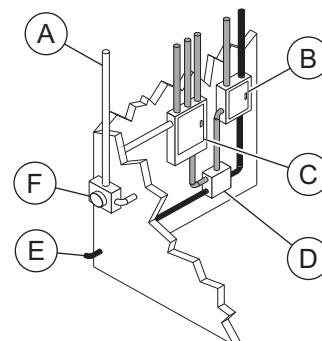

002807

Figure 3-10. Transfer Switch Operation

A	Incoming utility power
B	Emergency distribution panel (generator power)
C	Main distribution panel (utility power)
D	Transfer switch
E	Power from generator
F	Utility meter
WHITE	Incoming utility power
GRAY	Normal utility power circuit
BLACK	Emergency generator power circuit

AUTO Exercise Timer

The Power Zone controller is capable of starting and stopping the unit automatically, based on a programmable schedule.

Units installed in a standby application should be exercised regularly to maintain operating condition and to ensure responsiveness in an emergency situation. Proceed as follows to operate the unit in AUTO mode:

Accessing the Configuration Menu

1. With the unit stopped, press ▲, ►, ▼, or ◀ to navigate to the maintenance screens from any of the operator screens.
2. While on any maintenance screen, press ✓ and O simultaneously. The controller will display the Configuration menu.
3. To save any changes and exit the Configuration menu, press and hold ✓ for five seconds. To cancel

any changes and return to the maintenance screen, press and hold O for five seconds.

Set the Controller Clock

The schedule runs based on the time set in the controller clock. Proceed as follows to set the controller clock before setting the schedule:

1. Navigate to the maintenance group and press ► to access it.
2. Press ► to select the time section.
3. Set the time and date to the correct local time.

Set the Schedule

NOTE: The controller must be in AUTO mode to run at the programmed time. Use a trickle or solar battery charger to prevent the controller from draining the battery while in AUTO mode.

1. Access the scheduler group by pressing the ► button.

NOTE: The scheduler group consists of the scheduler options and scheduler setup sections. Each section can be accessed and exited using the ► and ◀ buttons.

2. Access the scheduler options section. Within this section, the scheduler can be enabled, run mode selected, and load mode selected.

Item	Values
Enable	Yes, No
Run Mode	Monthly, Weekly
Load	Idle, In Island, On Load, Off Load

3. Access the scheduler setup section. In this section, each schedule entry can be modified by pressing the ✓ button to select the item, and the ▲ and ▼ buttons to define them.

Item	Values
Schedule Entry	1 to 16
Start Time	00:00 to 23:59
Duration	00:00 to 99:59
Day	Monday through Sunday
Week (of month)	First, Second, Third, Fourth

NOTE: If setting up a daily scheduled run, select Weekly Run Mode, then set start time and duration for each day (seven schedule entries total). This will repeat the seven day schedule as long as the unit is in AUTO mode.

Setting Up a Daily Scheduled Run

1. Enable the scheduler.
2. Set RUN mode to Weekly.
3. Set load to preferred method.
4. Set the start time and duration for seven days (Monday–Sunday).
5. Set the controller to AUTO mode.

Set the Unit to AUTO Mode

From any operator or maintenance screen, press and hold the AUTO or MANUAL mode (☐) button for five seconds, or until AUTO mode is displayed at the top of the screen.

NOTE: If any of the scheduled time slots are currently active, the controller will begin the starting sequence and start the unit, provided there are no shutdown conditions present.

Shutting Down the Unit

Prior to shutting down the unit, check with personnel using power supplied by the generator and let them know the power is going to be turned off. Verify the power shut down will not create any hazards by accidentally turning off equipment that needs to be kept on (pumps, compressors, lights, etc.).

1. Remove all loads from the generator by opening all circuit breakers (turn OFF (O)).
2. Allow engine to run for approximately five minutes to allow it to cool down.
3. Press the red engine STOP (O) button on the controller. This will result in the generator going into the shutdown cycle and starting a 15 second shutdown timer. If the unit does not shut down within 15 seconds, a stop fail alarm will be displayed on the display screen.
4. After the unit shuts down, wait two minutes after engine shutdown for controller actuated actions to complete and then set the control power switch to OFF (O).

NOTE: Turning off the control panel before the controller finishes updating could cause a loss of data.

NOTE: For extended storage time, disconnect the battery. See the engine operator's manual for extended storage requirements.

Emergency Stop Switch



Equipment Damage. The emergency stop switch is not to be used to power down the unit under normal operating circumstances. Doing so could result in equipment damage. (000246b)

See [Figure 2-3](#). The unit is equipped with one emergency stop switch. The red button is clearly labeled EMERGENCY STOP. The switch can be accessed and activated with all doors closed and locked.

Activate the emergency stop switch by pushing the button in until it locks down. This trips the main circuit breaker which then opens the contact, disconnecting the load to the connection lugs. This will also open the fuel circuit, shutting down the engine. The emergency stop fault will be displayed on the control panel. The switch will remain closed until it is pulled out.

Idle Switch

The idle speed is 1,000 to 1,200 rpm. The engine will start at idle speed and run at idle for 15 seconds no matter what position the idle switch is in. After 15 seconds of running at idle, the unit will ramp up to 1,800 rpm if the idle switch is OFF. Otherwise the unit will continue to idle if the idle switch is ON.

When the engine is at idle speed (1,000 to 1,200 rpm), the voltage regulator will not function and the output voltage is dropped out by the voltage regulator.

IMPORTANT NOTE: Do not apply load to the unit when the engine is running at idle speed.

Using ECU Override



Equipment Damage. Do not start the engine with the Engine Control Unit (ECU) override switch ON. Doing so will damage the ECU. (000305)

IMPORTANT NOTE: Starting the engine with the ECU override switch ON will not allow the engine to shut down properly using the Engine STOP Button. This must only be used when the engine is OFF.

To access ECU override, put the controller in STOP mode and press the green START button. The top of the screen will read ECU OVERRIDE.

If the unit needs to be shut down immediately, use the emergency stop switch. See [Emergency Stop Switch](#).

Towing the Unit



Personal injury. Trailer must be securely coupled to the hitch with the chains correctly attached. Uncoupled or unchained towing could result in death or serious injury. (000233a)



Personal injury. Do not operate unit during transport. Doing so could result in death, serious injury, or property damage. (000231a)



Crushing hazard. Verify unit is properly secured and on level ground. An unsecured unit can suddenly roll or move, causing death or serious injury. (000234a)

1. Verify the engine is OFF.
2. Use the tongue jack to raise or lower the trailer onto the hitch of the towing vehicle. Lock the hitch coupling and attach the safety chains or cables to the vehicle. Release the jack locking pin and rotate the jack into the travel position. Verify the locking pin snaps into place.

NOTE: A film of grease on the coupler will extend coupler life and eliminate squeaking. Wipe the coupler clean and apply fresh grease each time the unit is towed.

3. Lubricate the grease fittings located on the leveling jacks to verify proper operation of the jacks. See [Jack Maintenance](#). For maintenance interval information, see [Basic Maintenance Schedule](#).
4. Connect trailer wiring to the tow vehicle. Check for proper operation of the directional and brake lights.
5. Verify all doors and hoods are properly latched.
6. Check for proper inflation of the trailer tires. Proper inflation is specified in [Specifications](#).
7. Check the wheel lugs. Tighten or replace any lugs that are loose or missing. If a tire has been removed for axle service or replaced, tighten the lugs in the order shown in [Figure 3-11](#) to the following specifications:
 - a. Start all lug nuts by hand.
 - b. First pass tighten to 20–25 ft-lb (27–33 Nm).
 - c. Second pass tighten to 50–60 ft-lb (67–81 Nm).
 - d. Third pass tighten to 90–120 ft-lb (122–162 Nm).

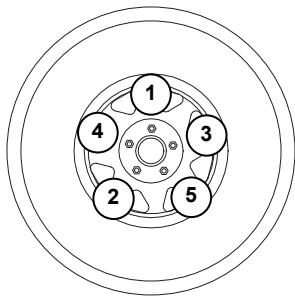

Figure 3-11. Lug Sequence

007620

WARNING

Property or Equipment Damage. Tighten wheel lug nuts after first 50 miles to factory specifications. Failure to do so could result in death, serious injury, property or equipment damage. (000235)

NOTE: Maximum recommended speed for highway towing is 45 mph (72 km/h). Recommended off-road towing speed is 10 mph (16 km/h).

Lifting the Unit



WARNING

Personal injury. Failure to properly connect lifting cables, chains, or straps could result in death, serious injury, or property damage. (000346)

WARNING

Personal Injury. Do not use lifting eye if there are signs of damage or corrosion. Doing so could result in death, serious injury, or property damage. (000433)

WARNING

Personal Injury. Do not use lifting eye other than as directed. Doing so could result in death, serious injury, or property damage. (000434)

1. Verify the equipment being used to lift the unit is in good condition and has sufficient capacity. For approximate weights, see [Specifications](#).
2. Close and lock all hoods and doors.

IMPORTANT NOTE: Always remain aware of people and objects around the work site when moving or lifting the unit.

3. See [Figure 3-12](#) for location of the central lift point (A).

4. Attach any slings, chains or hooks directly to the central lift point.

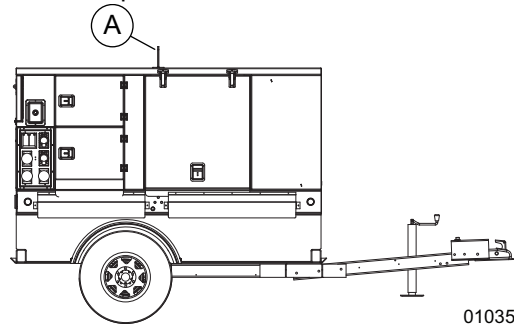

Figure 3-12. Lifting Points

01035

Tying Down the Unit

When securing the unit for transportation, verify the equipment being used to fasten the unit is in good condition and has sufficient strength to hold the unit in place during transport.

See [Figure 3-13](#). Use the tie-down points (A) as shown.

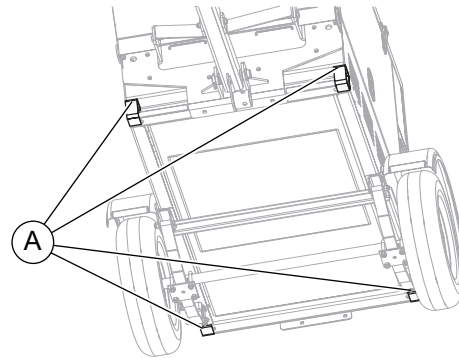

Figure 3-13. Tie-Down Points

007622

Section 4: Maintenance

Emissions Information

For emissions information, see the OEM diesel engine manual.

Maintenance

Regular maintenance ensures correct machine performance and extends engine/equipment life. Generac Mobile recommends that all maintenance work be performed by a GMASD. Regular maintenance, replacement, or repair of the emissions control devices and systems may be performed by any repair shop or person of the owner's choosing. To obtain emissions control warranty service free of charge, the work must be performed by a GMASD. See the emissions warranty.

Daily Walk Around Inspection



Equipment Damage. Failure to perform a daily inspection could result in damage to the unit.

(000306)

Inspect for conditions that could hinder performance or safety, such as (but not limited to) oil, coolant, and fuel leakage, blocked vents, loose or missing hardware, and improper electrical connections.

Inspect the fan belt for signs of cracking, fraying, and stretching, and verify the belt is properly seated in the pulley grooves. Replace the belt according to the manufacturer's recommendations.

NOTE: At the 500 hour or 12 month service interval, it is recommended that the belt be removed and checked for wear. While the belt is removed, inspect pulleys and bearings. Rotate and feel for hard turning or unusual sounds. Contact the engine manufacturer if pulleys or bearings need replacement.

Belt Tensioners

Isuzu engines use two types of belt tensioners: manual and automatic. Adjust the belt using the manual tensioner according to the manufacturer's specifications. The automatic tensioner cannot be adjusted or repaired and is designed to maintain proper tension over the belt's life. Units with an automatic belt tensioner must be inspected according to the manufacturer's specifications.

General Maintenance

Poorly maintained equipment can become a safety

hazard. Periodic maintenance and occasional repairs are necessary in order for the equipment to operate safely and properly over a long period of time. Never perform any routine service (oil and oil filter changes, cleaning, etc.) unless all electrical components are shut off. Before servicing the unit, always follow the instructions listed below.

- Verify the control power switch is turned OFF (O).
- Verify the circuit breakers are turned OFF (O).
- Activate (push in) the emergency stop switch.
- Disconnect the negative (-) terminal on the battery.
- Attach a DO NOT USE sign to the control panel. This signifies that the unit is being serviced and reduces the chance of someone inadvertently trying to start the unit.
- Do not wash the unit with a high pressure hose or with any kind of power washer.
- Do not wash the engine block or fuel tank with a power washer or steam cleaner. Water may enter the cabinet and collect in the generator windings or other electrical parts, causing damage.
- Inspect for water inside the cabinet and generator before each use if the unit is stored outside. If wet, dry the unit thoroughly before starting.
- Inspect condition of electrical cords. **DO NOT** use the unit if insulation is cut or worn through.
- Verify the condition of the air filter by viewing the level of the vacuum draw on the filter minder gauge. Replace the air filter when the yellow center bar reaches the red section on the gauge (20 in. H₂O).
- Inspect wheel lugs. See [Towing the Unit](#).
- Inspect wheel bearings. See [Trailer Wheel Bearings](#).
- Inspect the wheel bearings for unusual wear.
- Inspect coolant level daily. See the engine operator's manual for coolant recommendations and proper mixture.
 - Visually inspect the level in the coolant overflow tank located near the radiator.
 - Normal operating level is between the FULL and ADD markings on the overflow jug.
 - When engine is stopped and completely cool, coolant may be added directly to the coolant overflow container.
- Check the oil level daily. See the engine operator's manual for the proper viscosity grade of oil,

including special operating conditions such as a change in season or climate.

- **DO NOT** start the unit if the engine oil level is below the add mark on the dipstick.
- Normal operating level is between the dipstick FULL and ADD marks.
- Add oil only if the oil level is below the ADD mark on the dipstick.
- **DO NOT OVERFILL** the crankcase.
- Verify fuel level.
- Verify remote switch is OFF and tagged, if the unit is connected to a remote start or transfer switch.

NOTE: If the engine was run out of fuel, or the fuel tank was drained, it may be necessary to purge the fuel lines. See the engine operator's manual supplied with the unit for more information.

Engine Oil Recommendations

Contact a GMASD or refer to the applicable engine service manual for engine oil recommendations.

Coolant Recommendation



DANGER

Risk of poisoning. Do not use mouth to siphon coolant. Doing so will result in death or serious injury.

(000149)



WARNING

Risk of burns. Do not open coolant system until engine has completely cooled. Doing so could result in serious injury.

(000154)

CAUTION

Risk of overheating. Do not use any chromate base rust inhibitor with propylene glycol base antifreeze, boosters, or additives. Doing so will cause overheating and possible equipment damage.

(000165a)

Contact a GMASD or refer to the applicable engine service manual for engine coolant recommendations. See table below for mixtures.

Freezing Point: °F (°C)	-34 (-36)	-62 (-52)	-84 (-64)
Water: % Volume	50	40	30
Antifreeze: % Volume	50	60	70

NOTE: Maximum freeze protection is 70%.

Basic Maintenance Schedule

See the relevant OEM engine manual for a complete list of maintenance requirements. Failure to comply with the procedures as described in the engine manual will nullify the warranty, decrease performance, and cause equipment damage or premature equipment failure.

Maintenance records may be required to complete a warranty request.

IMPORTANT NOTE: Refer to the engine operator's manual for additional maintenance information.

Basic Maintenance Schedule—Isuzu Engine

Item	Daily	First 50 Hrs. (Break-in Period)	Every 250 Hrs.	Every 500 Hrs.	Every 2000 Hrs.	As Required
Check engine oil level	◆					
Check engine coolant level	◆					
Check fuel level	◆					
Drain fuel filter	◆					
Check tire pressure	◆					
Check all electrical connections	◆					
Clean battery	◆					
Check fan belt tension (replace if necessary)	◆					
Inspect radiator fins for debris; clean as required	◆					
Pre-heating condition check	◆					
Check engine starting and noise conditions	◆					
Check exhaust smoke condition	◆					
Perform Daily Walk Around Inspection	◆					
Replace engine oil		◆	◆ ¹	◆ ^{2 3}		
Replace fuel filter elements				◆ ³		
Clean water sedimenter element				◆ ³		
Electromagnetic pump filter replacement or cleaning				◆ ³		
Oil filter element replacement		◆		◆		
Replace air filter element				◆		
Lubricate leveling jacks				◆		
Checking Generator Drive Plate Torque				◆		
Replace fan belt					◆	

1 MMG25IF4 only.

2 MMG45IF4 only.

3 If the unit is operated in a harsh environment or fuel quality is questioned, replace every 250 hours instead of every 500 hours.

Basic Maintenance Schedule—John Deere Engine

Item	Daily	First 100 Hrs. (Break-in Period)	Every 250 Hrs.	Every 500 Hrs.	Every 2000 Hrs.	Every 6000 Hrs.	As Required
Check engine oil level	◆						
Check engine coolant level	◆						
Check fuel level	◆						
Check tire pressure	◆						
Check all electrical connections	◆						
Inspect radiator fins for debris; clean as required	◆						
Check fuel filter/water separator bowl	◆						
Check air cleaner dust valve restriction indicator gauge	◆ ¹						
Perform Daily Walk Around Inspection	◆						
Check oil vapor recirculation system/non-return valve			◆				
Change engine oil and replace oil filter		◆		◆ ²			
Replace oil vapor recirculation filter				◆			
Service battery				◆			
Replace fuel filter elements				◆			
Check engine mounts				◆			
Check air intake hoses, connections and system				◆			
Check engine electrical ground connection				◆			
Check automatic belt tensioner and belt wear				◆			
Check cooling system				◆			
Lubricate leveling jacks				◆			
Checking Generator Drive Plate Torque				◆			
Replace air cleaner elements					◆		
Replace alternator and fan belts					◆		
Test thermostats						◆	
Check fuses							◆
Add coolant							◆
Check electrical wiring and connections							◆

1 Replace primary air cleaner when dust valve restriction gauge shows a vacuum of 25 in H₂O.

2 If not using John Deere Plus 50 II engine oil, the interval must be decreased to every 250 hours.

Engine Break-In Requirements—Isuzu

NOTE: The EPA final Tier 4 Isuzu engines have an engine break-in duration that will prohibit the unit from providing rated standby power upon factory delivery. The unit is tested at the factory and is initially capable of a prime standby power output. The engine performance will increase to 95% of full rated power during the first 20 hours of loaded operation. The unit will provide full power after the complete engine break-in period of 70 hours of loaded operation.

Operate the engine at heavy loads (60–90% of maximum) as much as possible. If the engine has spent significant time at idle, constant speed(s), or light load, or if makeup oil is required, a longer break in period may be needed. Refer to the engine operator's manual for a full description of necessary procedures on the addition of break-in oil and extension of the break-in period. For more information on regular maintenance intervals, refer to [Basic Maintenance Schedule—Isuzu Engine](#).

Engine Break-In Requirements—John Deere

NOTE: During the first 20 hours of operation, avoid long periods of no load or sustained maximum load operation. If the generator is to run for longer than five minutes without a load, shut down the generator.

Operate the engine at heavy loads (60–90% of maximum) as much as possible. If the engine has spent significant time at idle, constant speed(s), or light load, or if makeup oil is required, a longer break in period may be needed. Refer to the engine operator's manual for a full description of necessary procedures on the addition of break-in oil and extension of the break-in period. For more information on regular maintenance intervals, refer to [Basic Maintenance Schedule—John Deere Engine](#).

Resetting Maintenance Alarms

The Power Zone controller will display a warning message when the unit is due for maintenance or service. The maintenance or service interval is set at 250, 500, and 3,000 hours of engine running time. Once the unit has been serviced, the appropriate maintenance alarm reminder must be reset. Proceed as follows to reset the maintenance alarms:

1. With the unit shut down, move the control power switch to CONTROL ON (I). The controller will toggle automatically to the home screen after initialization.
2. Press ▲, ►, ▼, or ◀ to enter the maintenance screens.
3. Press ✓ and O simultaneously. The next screen displays the Configuration menu.

4. Press ▼ to move the cursor (blue highlighted text) down to the maintenance group.
5. Press ► to access the sections. Press ▼ to highlight the maintenance section.
6. Press ► to access the parameters and highlight the maintenance alarm that needs to be reset.
7. Press ✓ to select the editable parameters. The cursor will highlight NOT RESET under the selected maintenance alarm. Press ▲ to highlight RESET.
8. Press ✓ to reset the selected maintenance alarm.
9. To perform additional maintenance alarm resets, repeat steps 6–8.

NOTE: If the selected maintenance alarm does not need to be reset, press ▼ to highlight Not Reset and press ✓ to return to the parameters section.

10. Press and hold ✓ for five seconds to save changes. Press and hold O for five seconds to discard changes made.

Exhaust Filter Service Requirements



Hazardous Material. Only an authorized engine service dealer should remove, handle and dispose of Diesel Particulate Filter (DPF) ash. Failure to dispose of DPF ash properly could result in serious injury and environmental damage.

(000307)

The exhaust filter system contains a Diesel Particulate Filter (DPF). Over time, the DPF will require professional servicing to remove ash buildup. The expected service interval will be at least 3,000 or 4,500 hours, based on engine power and operating conditions. Actual service should take place when the indicator light appears on the controller. The DPF should be cleaned or replaced by an authorized service provider only.

To avoid buildup of diesel particulates or soot in the exhaust filter system:

- Utilize the Automatic Exhaust Filter Cleaning mode.
- Avoid unnecessary idling.
- Use proper engine oil. See the engine operator's manual.
- Use only ultra low sulfur diesel fuel. See the engine operator's manual.
- Do not run with less than 30% of a full load.

Checking Generator Drive Plate Torque

1. Disconnect battery.
2. Remove generator fan guard.

3. Tighten each drive plate bolt as shown below.

Unit	Torque: ft-lb (Nm)
MMG25IF4	30 (40)
MMG35DF4	40 (54)
MMG45IF4	30 (40)
MMG55DF4	40 (54)

4. Install generator fan guard.
5. Connect battery.

Jack Maintenance

The following procedures should be performed annually.

Side-Wind Models

- The internal gearing and bushings of the jack must be kept lubricated. Apply a small amount of automotive grease to the internal gearing by removing the jack cover, or if equipped, use a needle nose applicator or standard grease gun on the lubrication point on the side of the jack near the crank. Rotate the jack handle to distribute the grease evenly.
- A lightweight oil must be applied to the handle unit at both sides of the tube.
- If equipped, the axle bolt and nut assembly of the caster wheel must also be lubricated with the same lightweight oil.

Top-Wind Models

- Apply a lightweight oil to the screw stem.

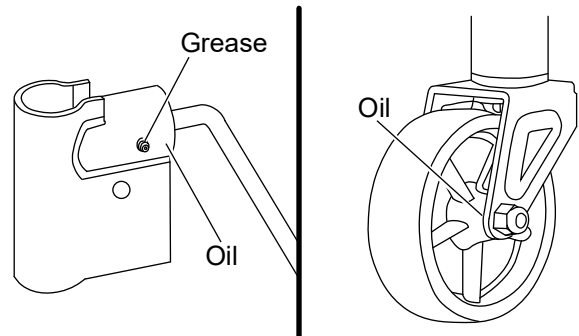
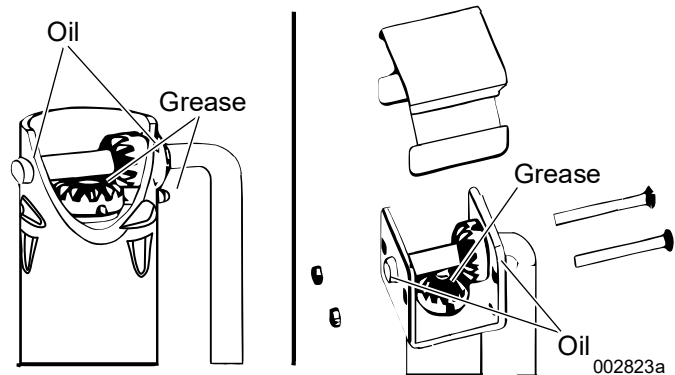

002824a

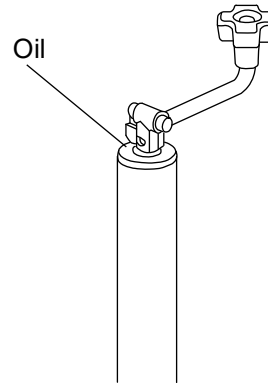

002825a

Figure 4-1. Lubrication Points

Trailer Wheel Bearings

The trailer axles are equipped with a grease fitting to allow lubrication of the wheel bearings without needing to disassemble the axle hub. To lubricate the axle bearings, remove the small rubber plug on the grease cap, attach a standard grease gun fitting to the grease fitting, and pump grease into the fitting until new grease is visible around the nozzle of the grease gun. Use only a high quality grease made specifically for lubrication of wheel bearings. Wipe any excess grease from the hub with a clean cloth and replace the rubber plug when finished. The minimum recommended lubrication is every 12 months or 12,000 miles (19,312 km). More frequent lubrication may be required under extremely dusty or damp operating conditions.

Section 5: Troubleshooting

General Troubleshooting

This information is intended to be a check or verification for simple causes that can be located and fixed. It does not cover all types of problems. See the engine operator's manual for additional troubleshooting

information. Procedures that require in-depth knowledge or skills should be performed by a GMASD.

Problem	Possible Cause	Solution
Low fuel level Shutdown	Low fuel level	Check fuel level in LCD window of controller.
	Unit not level	Confirm that unit is sitting level to ensure an accurate reading.
	Fuel tank leaking	Check tank for leaks.
	Damaged fuel sender or wiring	Check for continuity between sender and engine controller. (See Wiring Diagrams .)
Low oil pressure shutdown	Low oil level	Check oil level on dipstick. Add oil, if needed.
	Oil leaking from engine	Visually inspect the engine for leaks. Restart unit and verify loss of pressure. Shut down immediately if pressure does not reach 5 psi (34 kPa) within five seconds.
	Oil pressure sender	See engine operator's manual to identify corrective action.
Low coolant level shutdown	Low coolant level	Allow engine to cool, then check coolant level in radiator. Add coolant, if needed.
	Coolant hoses leaking	Inspect hoses for leaks. Repair or replace as necessary.
	Engine block or water pump leaking	Visually inspect for leaks. Verify no coolant has mixed with the engine oil (oil will appear milky). See engine operator's manual for additional information.
High coolant temperature shutdown	Low coolant level	Add coolant if needed. Allow engine to cool, then check coolant level in radiator. Restart engine and check coolant temperature (on controller). Stop engine immediately if temperature is 210 °F (99 °C) or 230 °F (110 °C).
	Blockage in radiator	Check radiator shroud and ducting for blockage and remove any foreign matter.
	Leakage in coolant hoses, engine block, or water pump	Inspect for visible leaks. Check tension of water pump serpentine drive belt. Remove load on generator and restart engine. Check coolant temperature and shut engine down immediately if it starts to over-heat [230 °F (110 °C) or higher]. See the engine operator's manual for additional information on engine overheating.
Overcrank shutdown	Fuel level low	Check fuel level in tank. Check fuel pump operation. Check air filter for blockage. See engine operator's manual for additional information.
Overspeed or underspeed shutdown	Frequency setting incorrect	Disconnect all loads and restart unit. Read frequency (Hz) in the LCD window on controller. Frequency should read 60 Hz. If frequency is above 60 Hz, engine speed will need to be adjusted. Contact Isuzu to adjust speed.

This page intentionally left blank.

Section 6: Wiring Diagrams

3-Position AC Box

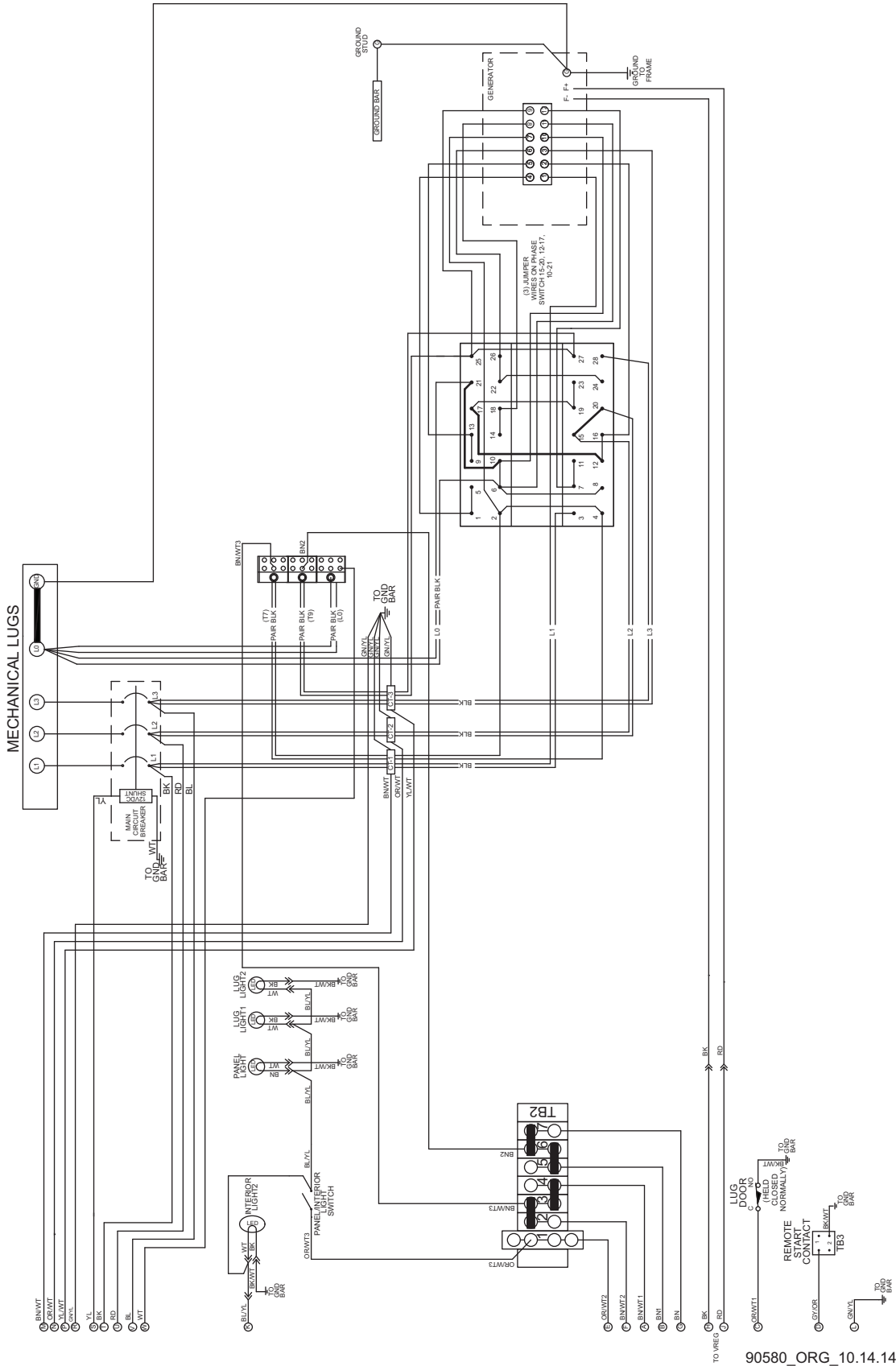

3-Position AC Box

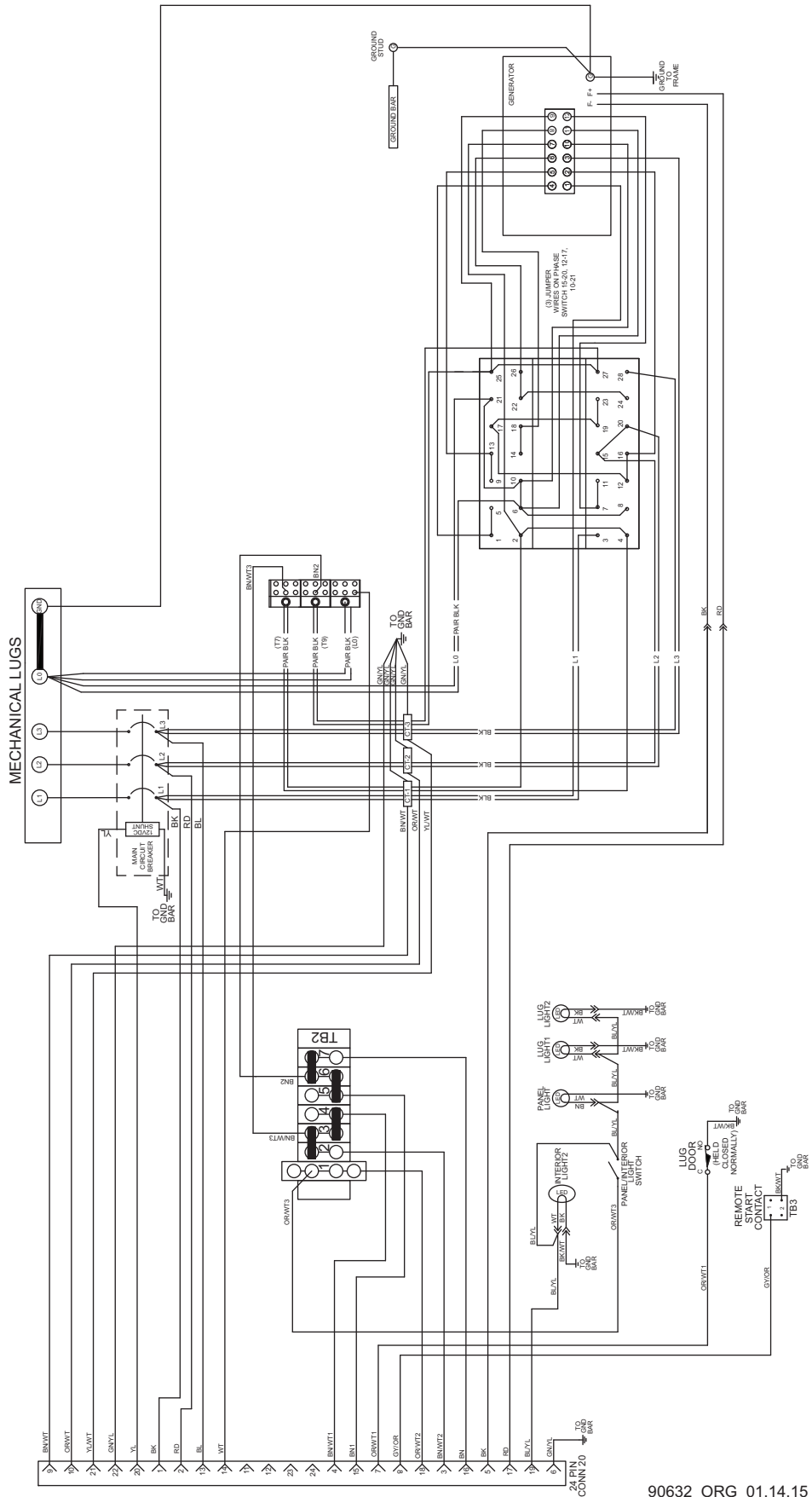

90632_ORG_01.14.15

4-Position AC Box

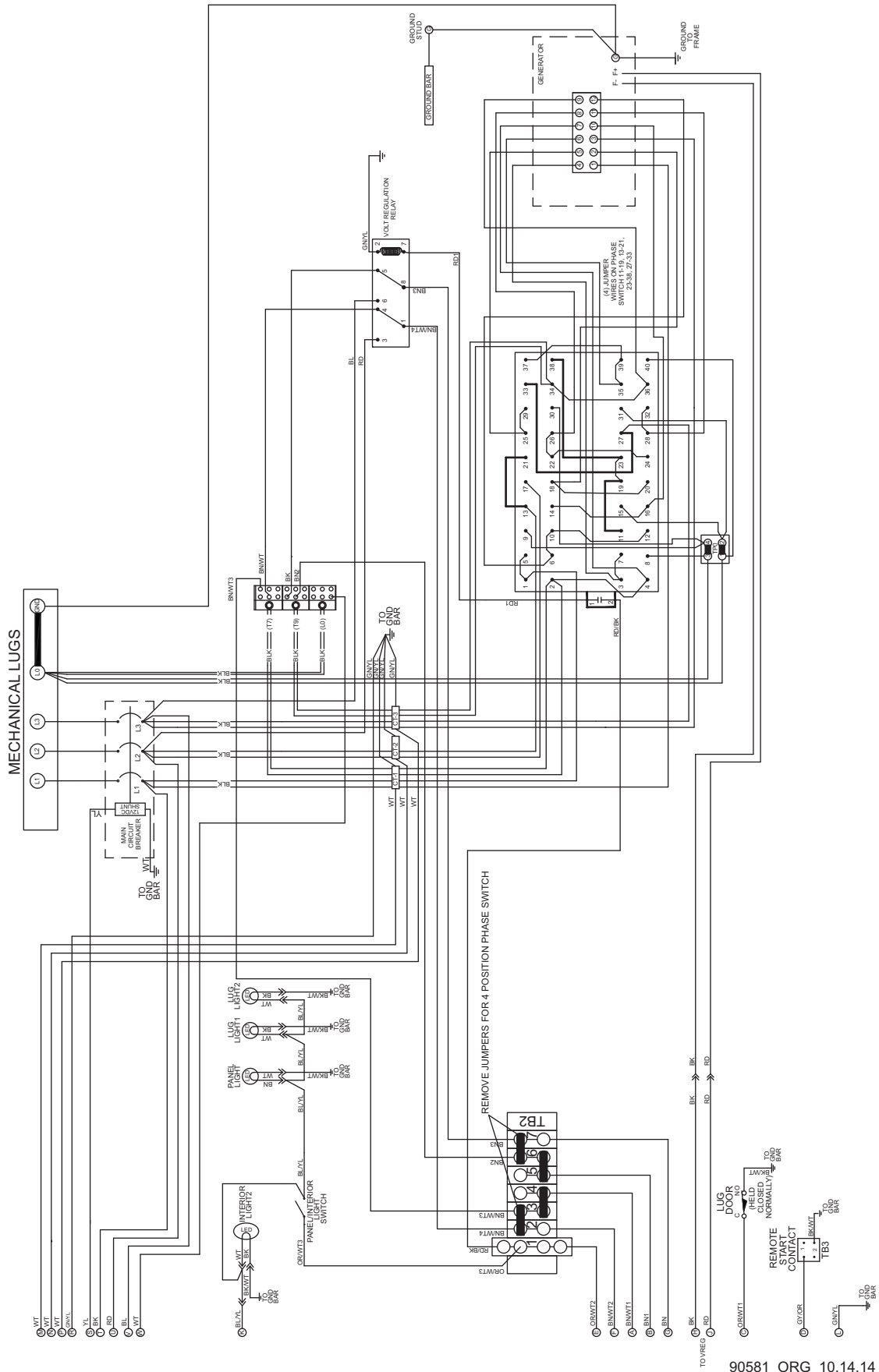

Receptacles

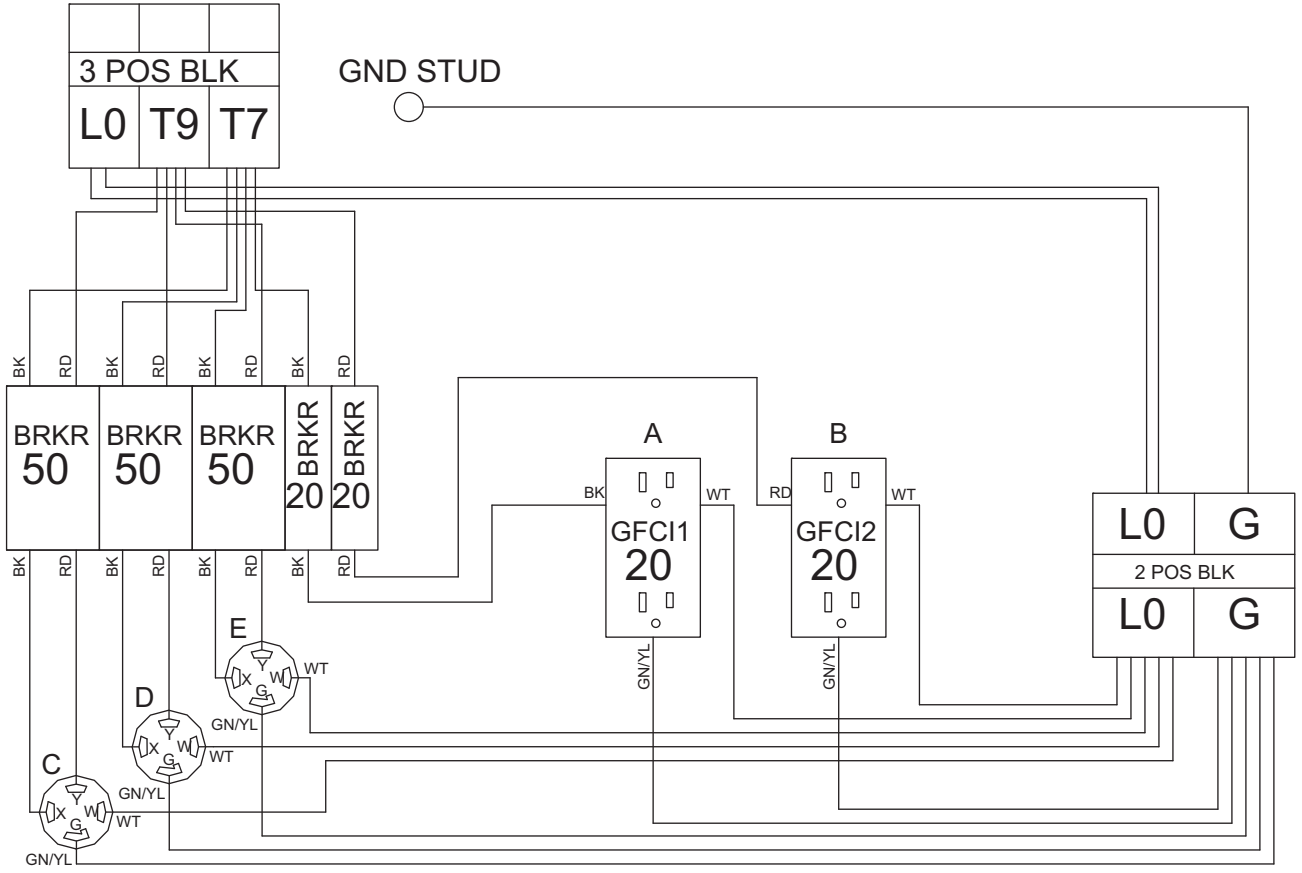

90582_ORG_08.18.14

Engine Heater

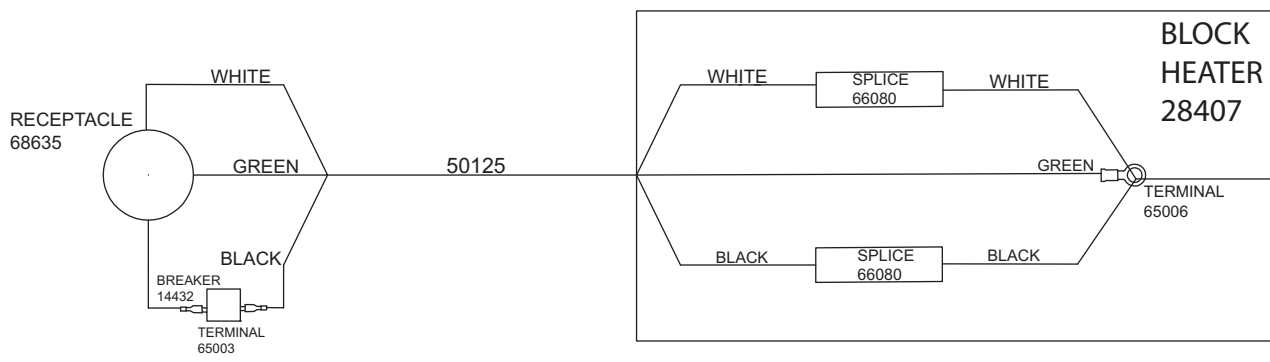

90594_C_07.21.16

Wiring Buck (If Equipped)

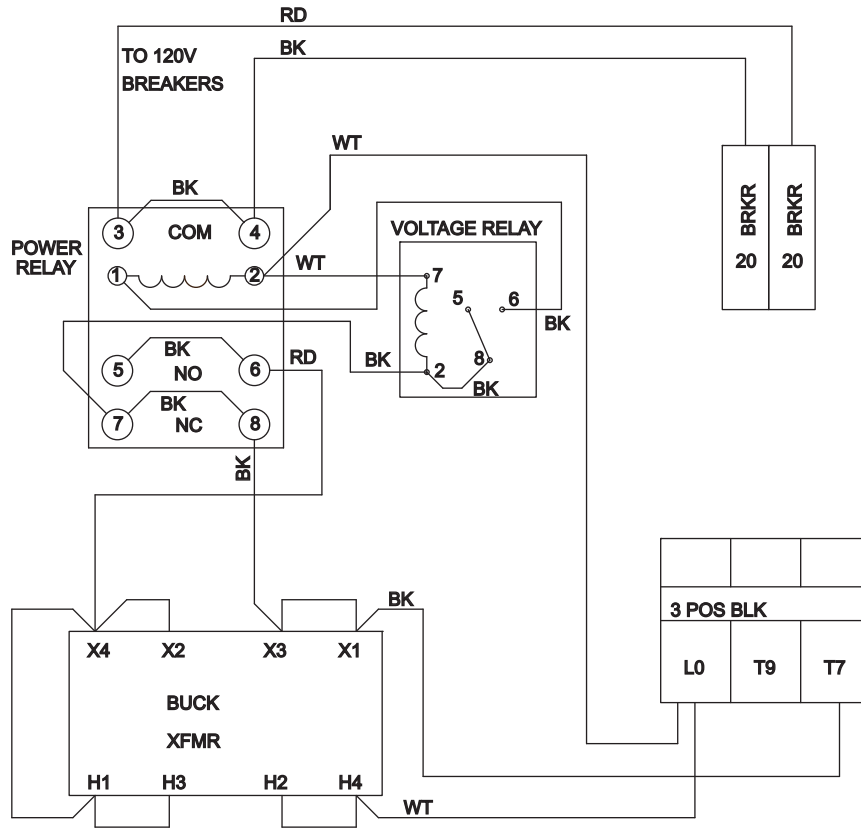

90583_ORG_08.18.14

Power Zone PMG

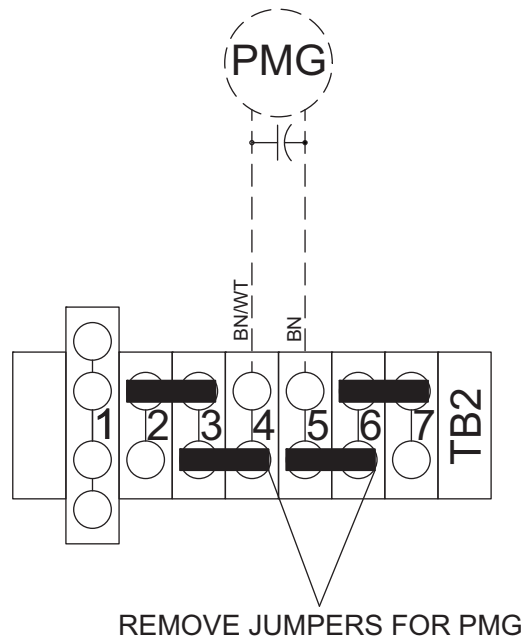

90589_ORG_08.18.14

Power Zone Control Box

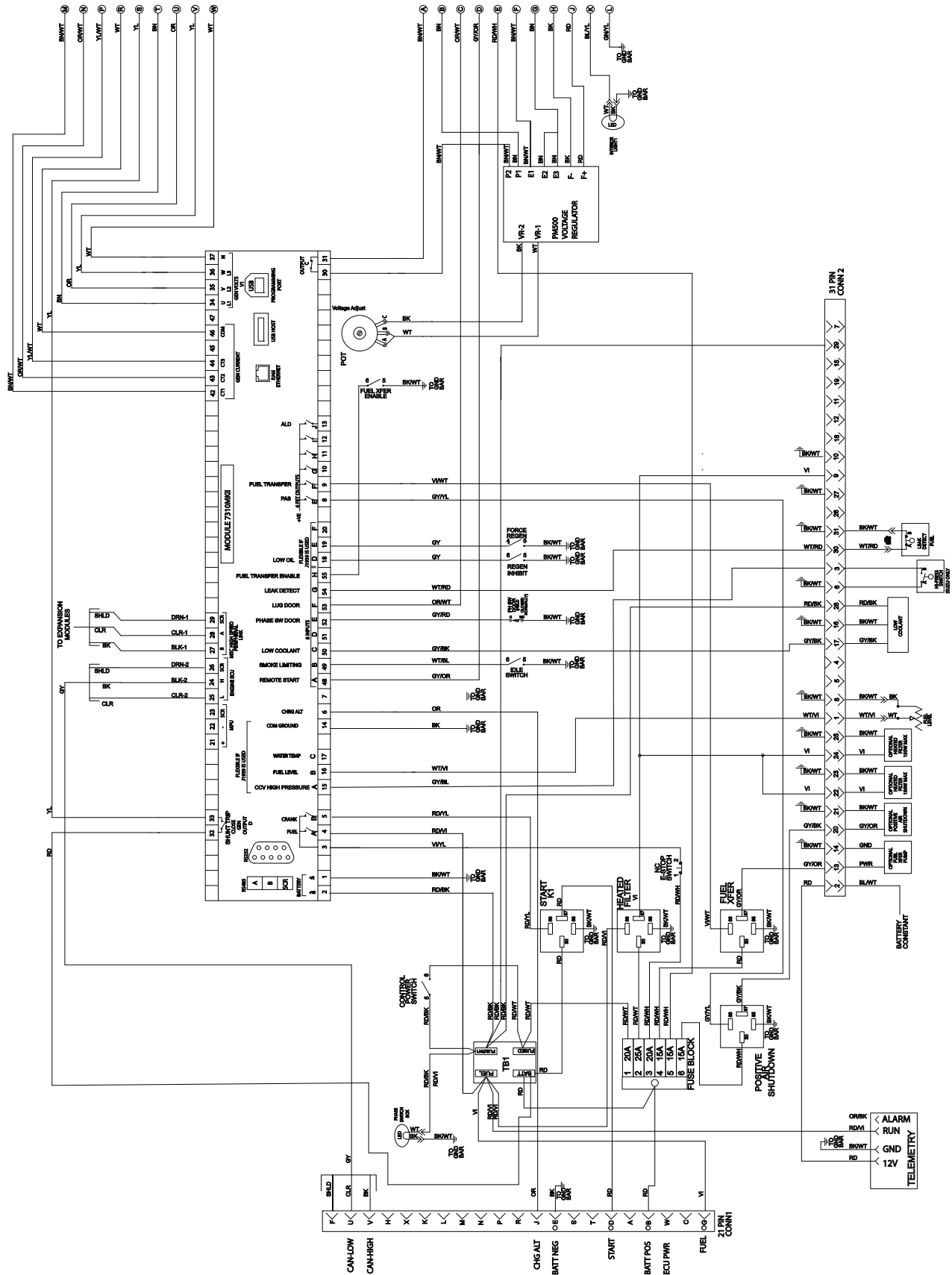

A0004066993_A_02.24.23

Trailer Lights

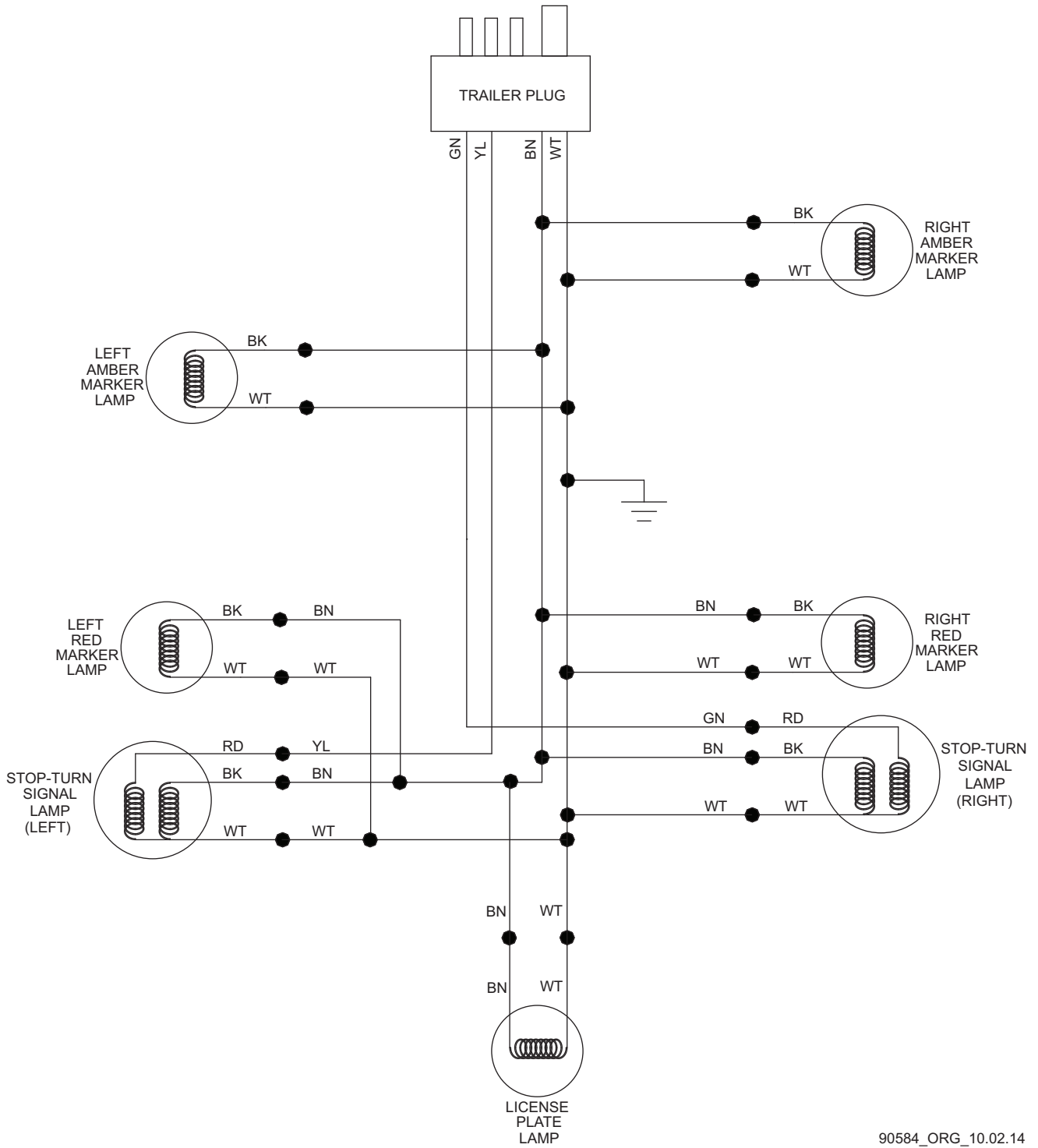

90584_ORG_10.02.14

Brake Wiring

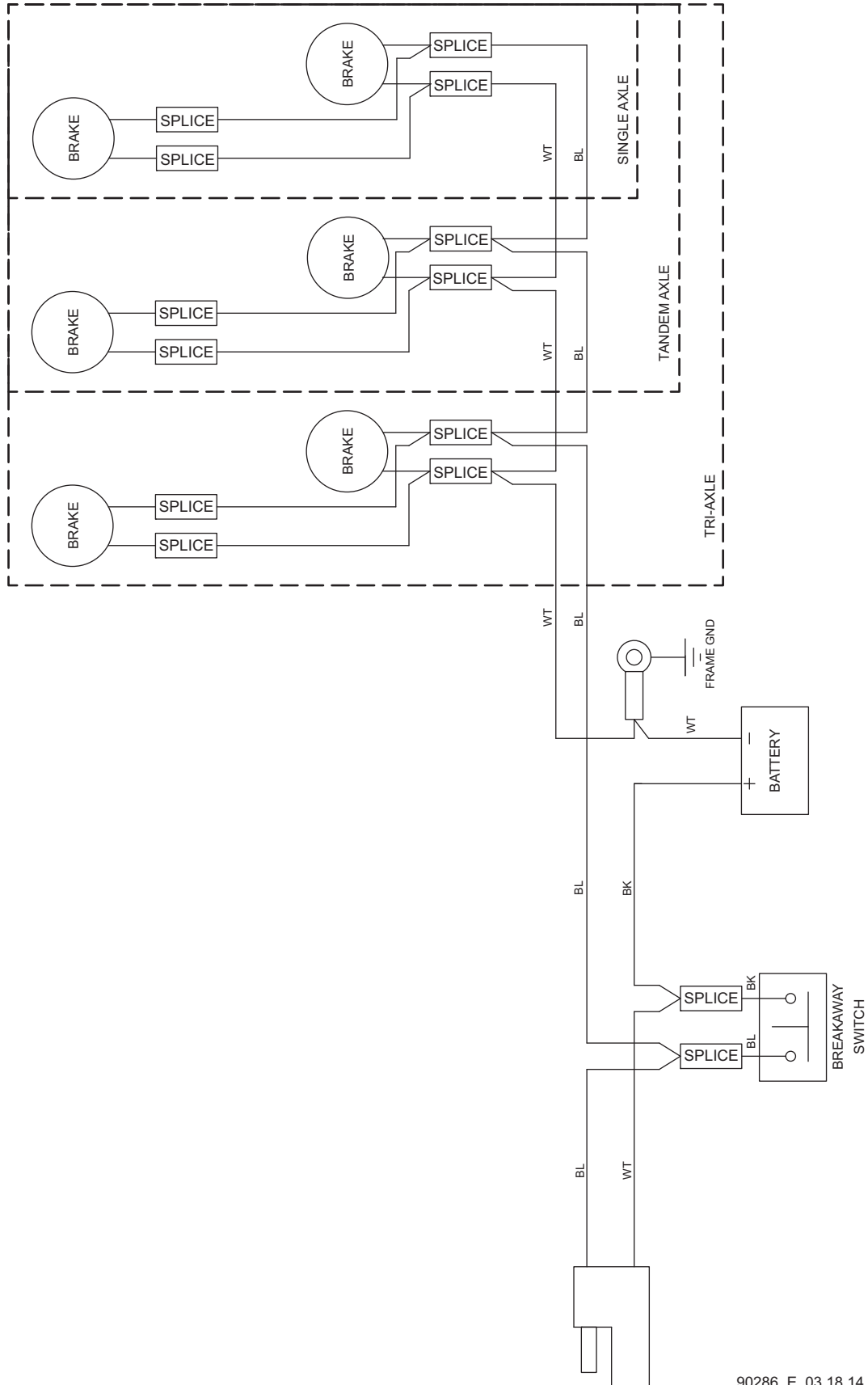

90286_E_03.18.14

12-Volt Battery Charger

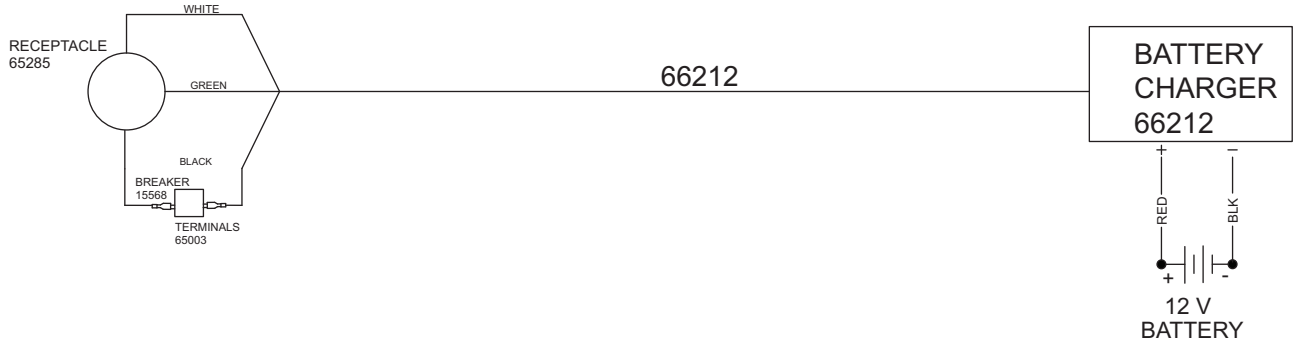

90593_B_09.19.16

Power Zone Low Oil Level (If Equipped)

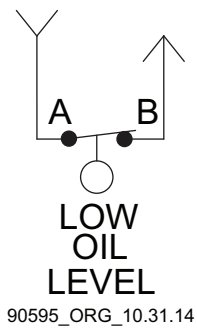

Part No. 36949 Rev. **G** 04/12/2023

©2023 Generac Power Systems, Inc.

All rights reserved.

Specifications are subject to change without notice.

No reproduction allowed in any form without prior written consent
from Generac Power Systems, Inc.

GENERAC® | **MOBILE**

Generac Power Systems, Inc.

S45 W29290 Hwy. 59, Waukesha WI 53189

[GeneracMobileProducts.com](https://www.GeneracMobileProducts.com) | 844-ASK-GNRC | 844-275-4672