

MFH900TDP

Flame-less Heater Parts Manual

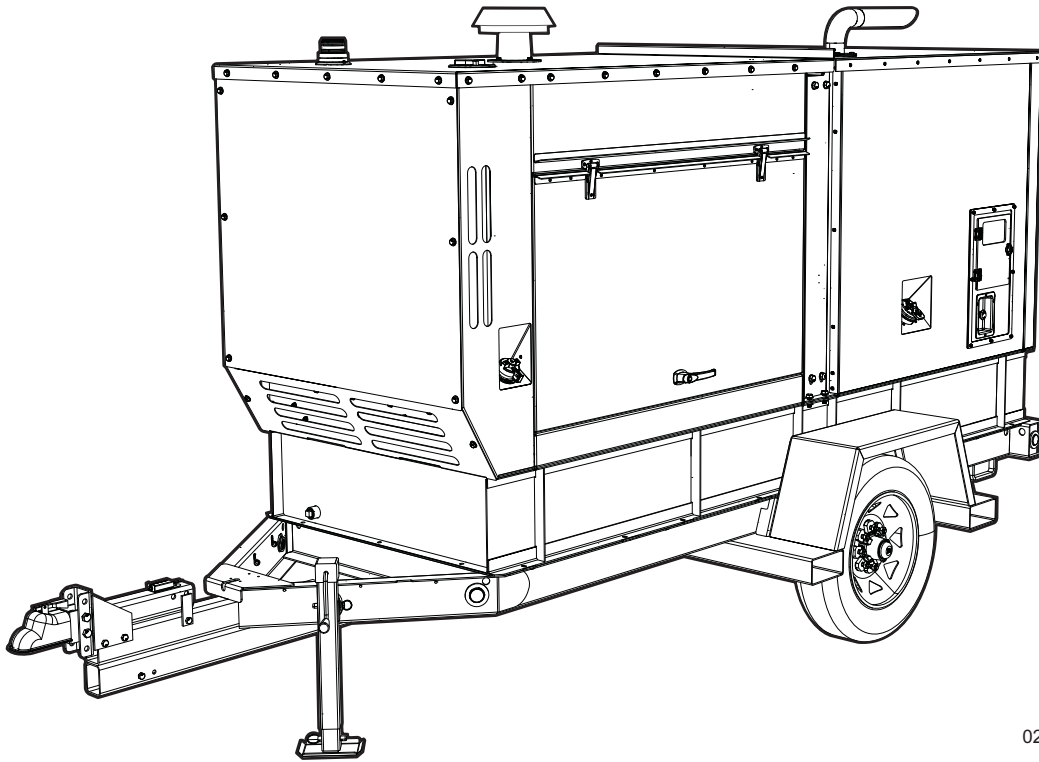

02914

MODEL NUMBER: _____

SERIAL NUMBER: _____

DATE PURCHASED: _____

SAVE THIS MANUAL FOR FUTURE REFERENCE

 **WARNING**

CANCER AND REPRODUCTIVE HARM

www.P65Warnings.ca.gov.

(000393a)

 **WARNING**

Breathing diesel engine exhaust exposes you to chemicals known to the State of California to cause cancer and birth defects or other reproductive harm.

- Always start and operate the engine in a well-ventilated area.
- If in an enclosed area, vent the exhaust to the outside.
- Do not modify or tamper with the exhaust system.
- Do not idle the engine except as necessary.

For more information go to

www.P65Warnings.ca.gov/diesel.

(000394)

Introduction

This parts manual was prepared based on the information available at the time of publication and is subject to change without notice. Generac Mobile Products reserves the right to change parts at any time. To check whether a revised parts manual is available, contact Generac Mobile Products.

DO NOT MODIFY or use this equipment for any application other than which it was designed for. To keep your equipment fully operational, it is suggested you maintain a stock of commonly used maintenance or service parts. A recommended spare parts list can be found in the back of this manual. To order service parts, please go to www.generacmobileproducts.com or call Generac Mobile Products.



WARNING

Consult Manual. Read and understand manual completely before using product. Failure to completely understand manual and product could result in death or serious injury.

(000100a)

WARNING

Environmental Hazard. Always recycle batteries at an official recycling center in accordance with all local laws and regulations. Failure to do so could result in environmental damage, death, or serious injury.

(000228)

GENERAC MOBILE PRODUCTS LLC

215 Power Drive • Berlin, WI 54923 U.S.A.

Phone: 920-361-4442

FAX: 920-361-4416

Toll Free: 1-800-926-9768

www.generacmobileproducts.com

For technical or parts QUESTIONS, contact Generac Mobile Products Technical Service at 1-800-926-9768.

Engine Make: _____

Engine Serial Number: _____

Engine Model Number: _____

This Page Intentionally Left Blank

Table of Contents

Introduction	iii
Parts Manual Instructions	1
Decal Location	2
Enclosure Panels	4
Roof and Doors to Unit	6
Front Enclosure Panels to Unit	8
Rear Enclosure Panels to Unit	10
Assembly - Rear Enclosure Panels	12
Assembly - Rear Door	14
Assembly - Front Enclosure Panels	16
Assembly - Forward Door	18
Assembly - Rear Panel - Left	20
Assembly - Exhaust Panel	22
Assembly - Control Box	24
Air to Air Exchange Assembly	26
Hydraulic Tank Assembly	28
Hydraulic Heat Manifold Assembly	30
Assembly - DEF Tank and Radiator Shroud	32
Assembly - Cooling System	34
Engine Assembly	36
Pump Assembly	38
Tank and Lift Structure Assembly	40
Trailer Assembly	42
Recommended Spare Parts	44

This Page Intentionally Left Blank

Parts Manual Instructions

Product illustrations are only representations. Products supplied may vary from the illustrations in this parts manual. Parts not shown in the illustration are indicated by a double dash (--) in the item column.

Please be prepared to provide the following information when ordering replacement parts: model number, serial number (on unit serial tag), part number, purchase order number (if applicable), shipping address, shipping method.

Refer to the illustration below to locate the unit ID tag and Vehicle Identification Number (VIN) tag on the unit. Important information, such as the unit serial number, model number, VIN and tire loading information are found on these tags. Record the information from these tags so it is available if the tags are lost or damaged. When ordering parts or requesting assistance, you may be asked to provide this information.

SERIAL TAG

(located on engine mount on inside of unit)

Manufactured by Generac Mobile Products LLC			
(920) 361-4442		(800) 926-9768	
Country of Origin	Model	Serial Number	
<input type="text"/>	<input type="text"/>	<input type="text"/>	
Manufacturing Code	Weight (lbs/kg)	RPM/Frequency	
<input type="text"/>	<input type="text"/>	<input type="text"/>	
		Rating	
		<input type="text"/>	
1 ph. 1.0PF	3 ph. .8PF	3 ph. 1.0PF	
KW <input type="text"/>	<input type="text"/>	<input type="text"/>	<input type="text"/>
KVA <input type="text"/>	<input type="text"/>	<input type="text"/>	<input type="text"/>
V <input type="text"/>	<input type="text"/>	<input type="text"/>	<input type="text"/>
A <input type="text"/>	<input type="text"/>	<input type="text"/>	<input type="text"/>
			Ins. Class
			<input type="text"/>
			 FOR ELECTRICAL EQUIPMENT UL LISTED PRODUCT ELECTRICAL EQUIPMENT CLASSIFICATION

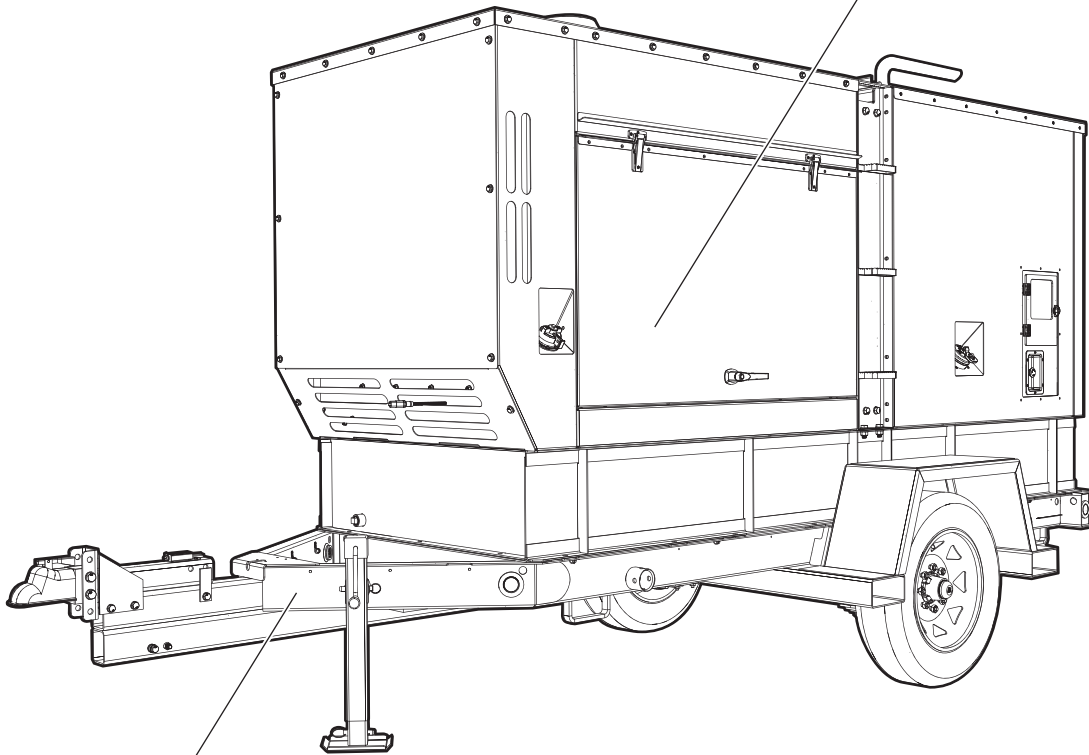

VIN TAG

MANUFACTURED BY/FABRIQUE PAR: Generac Mobile Products, LLC		DATE: 000000	
COUNTRY/PAIS: 0000000000		SOLD IN/ VENTE: 000000	
GAUGE / Jauge	TIRE / PNEU	RM / JANTE	PRÉSE. DE
<input type="text"/>	<input type="text"/>	<input type="text"/>	<input type="text"/>
VIN: 00000000000000000000		MODEL: XXX000	
TYPE: TRAILER			
TIRE AND LOADING INFORMATION		PNEUS ET LE CHARGEMENT	
The weight of cargo should never exceed 000000 (000000LB)		Le poids de chargement ne doit jamais dépasser 000000 (000000LB)	
SAFETY INFORMATION		INFORMATION	
SEE THE USER MANUAL FOR MORE INFORMATION		VOIR LE MANUEL D'UTILISATEUR POUR PLUS DE DÉTAILS	

02894

DECAL LOCATION

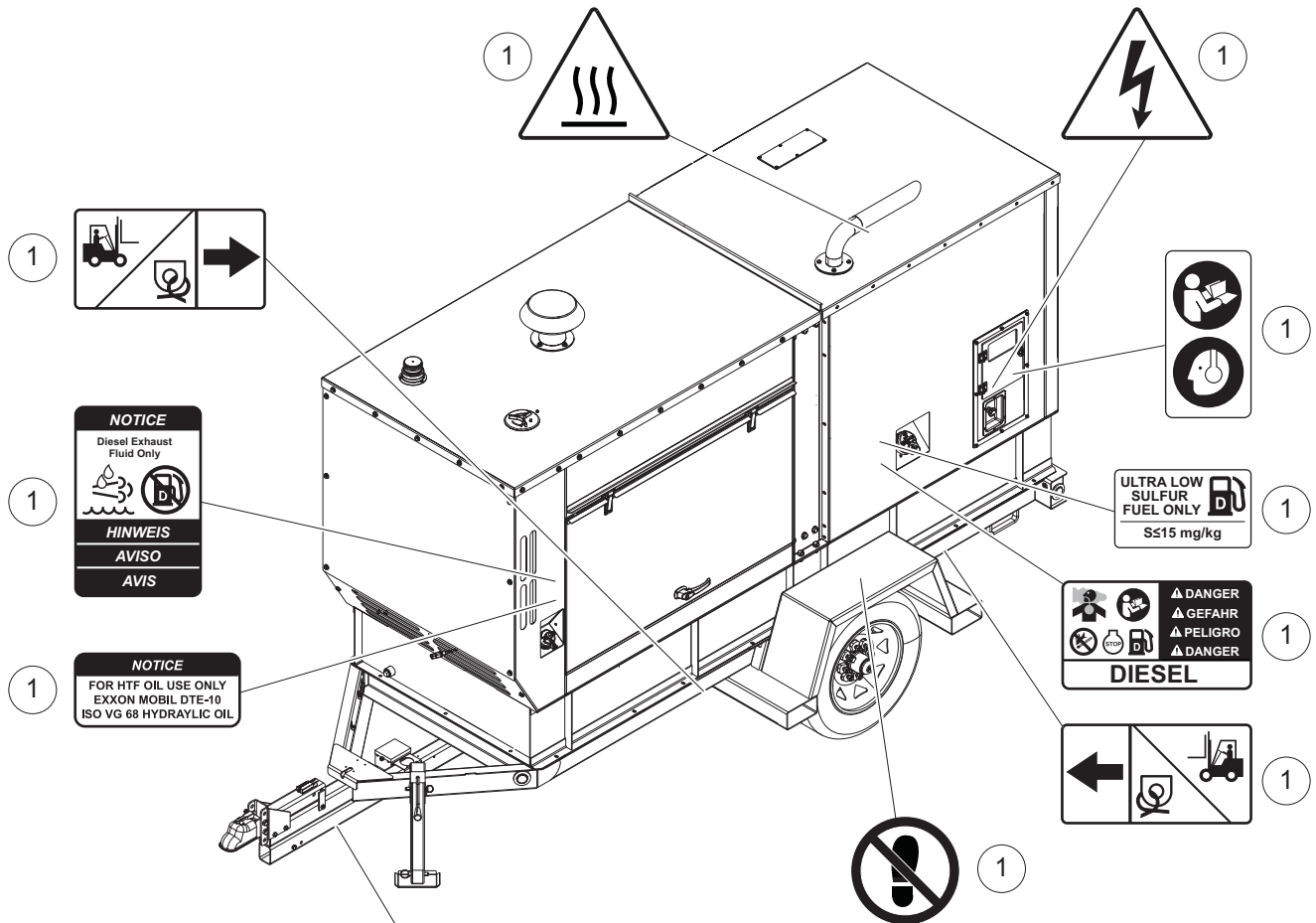

TOWING INSTRUCTIONS	ABSCHEPPINGSTRUKTUREN	INSTRUCCIONES DE REMOLQUE	INSTRUZIONI DI REMORQUAGGIO
<ol style="list-style-type: none"> Read operator's manual. Use only rated for trailer's gross vehicle weight (GVW). Securely attach trailer to tow vehicle. Always make proper safety air-coupling. Always use proper hitching technique. Check trailer lights. 	<ol style="list-style-type: none"> Beobachten Sie das Gewicht. Anhängervorrichtung verwenden, die den Gewichtsempfehlungen entspricht. Anhänger sicher am Zugfahrzeug befestigen. Sicherheitskupplung einwandfrei anbringen. Beachten Sie die Anhängertechnik. Anhängersicherheits prüfen. 	<ol style="list-style-type: none"> Lee el manual del operador. Utilice un equipo conectado clasificado para la "Carga de peso bruto" del vehículo de remolque. Desarrolle un acople correcto y asegure el vehículo de remolque. Siempre asegure los cables de seguridad. Siempre asegure el remolque a la cabina de desplazamiento. Compruebe las luces del remolque. 	<ol style="list-style-type: none"> Lire le notice d'emploi. Utiliser un coupleur d'attelage conforme au poids maximal du poids brut du véhicule de remorque. Assurer la connexion sécuritaire de toutes les liaisons. Attacher les chaînes de sécurité en utilisant une méthode correcte. Vérifier les chaînes de remorquage au véhicule. Vérifier les lampes de remorque.

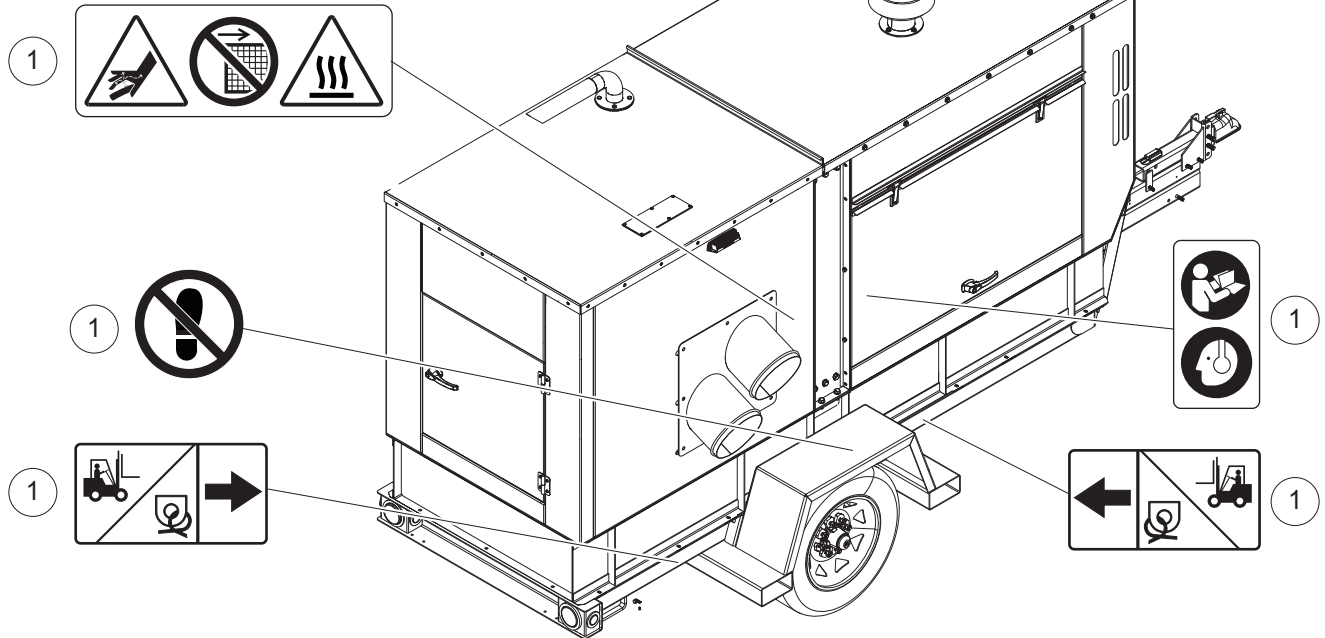

02895

DECAL LOCATION

Item	Part No.	Qty	Description	Notes
1	A0000302669	1	Decal, safety	

ENCLOSURE PANELS

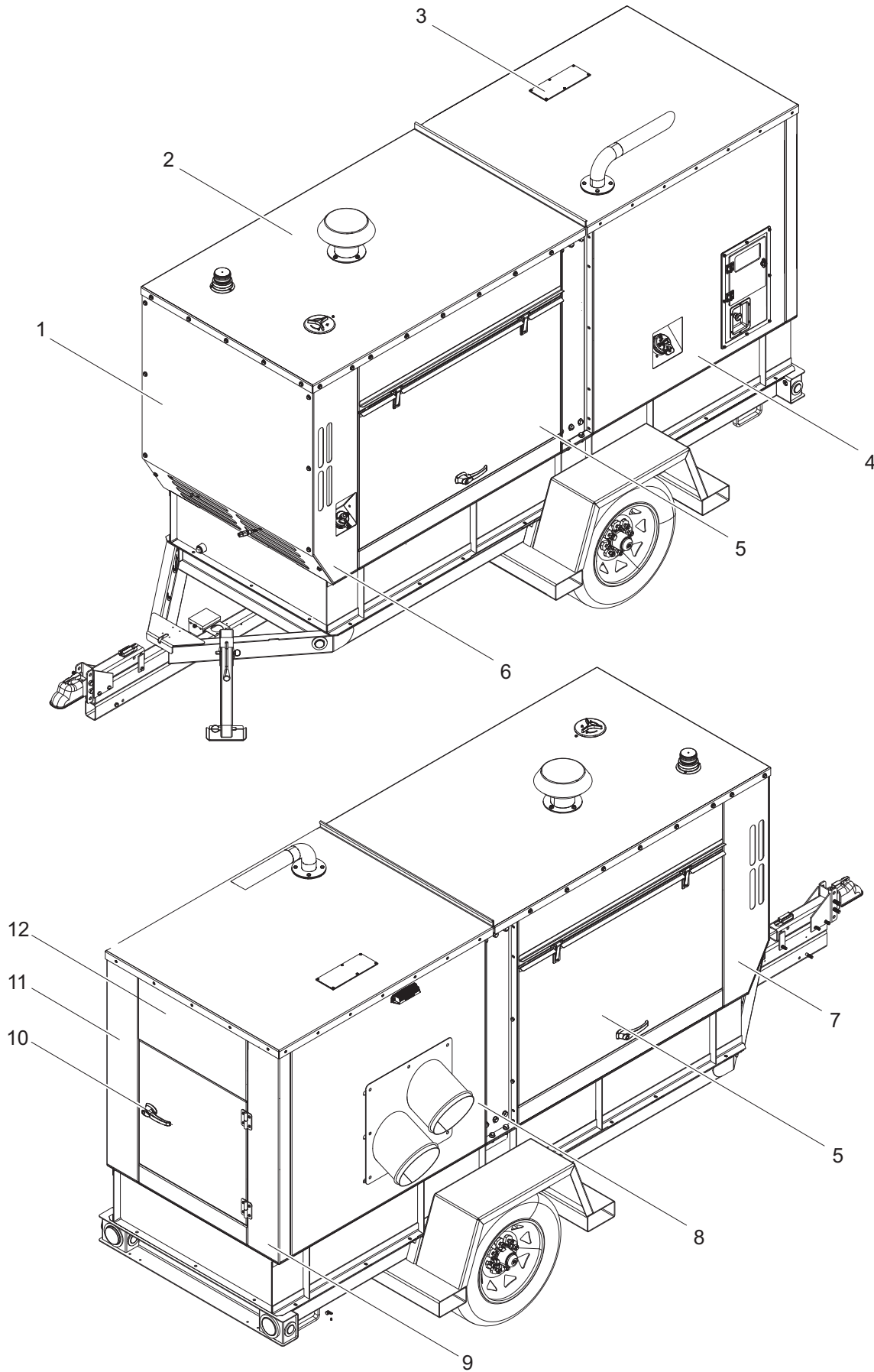

02896

ENCLOSURE PANELS

Item	Part No.	Qty	Description	Notes
1	A0000389489	1	Assembly, front panel	
2	A0000389496	1	Assembly, front roof panel	
3	A0000389501	1	Assembly, rear roof panel	
4	A0000389627	1	Assembly, rear panel - left	
5	A0000389562	2	Assembly, forward door	
6	A0000389623	1	Assembly, front jamb - left	
7	A0000389625	1	Assembly, front jamb - right	
8	A0000389628	1	Assembly, rear panel - right	
9	A0000389630	1	Assembly, corner - right	
10	A0000389567	1	Assembly, rear door	
11	A0000389631	1	Assembly, corner - left	
12	A0000389633	1	Assembly, rear panel	

ROOF AND DOORS TO UNIT

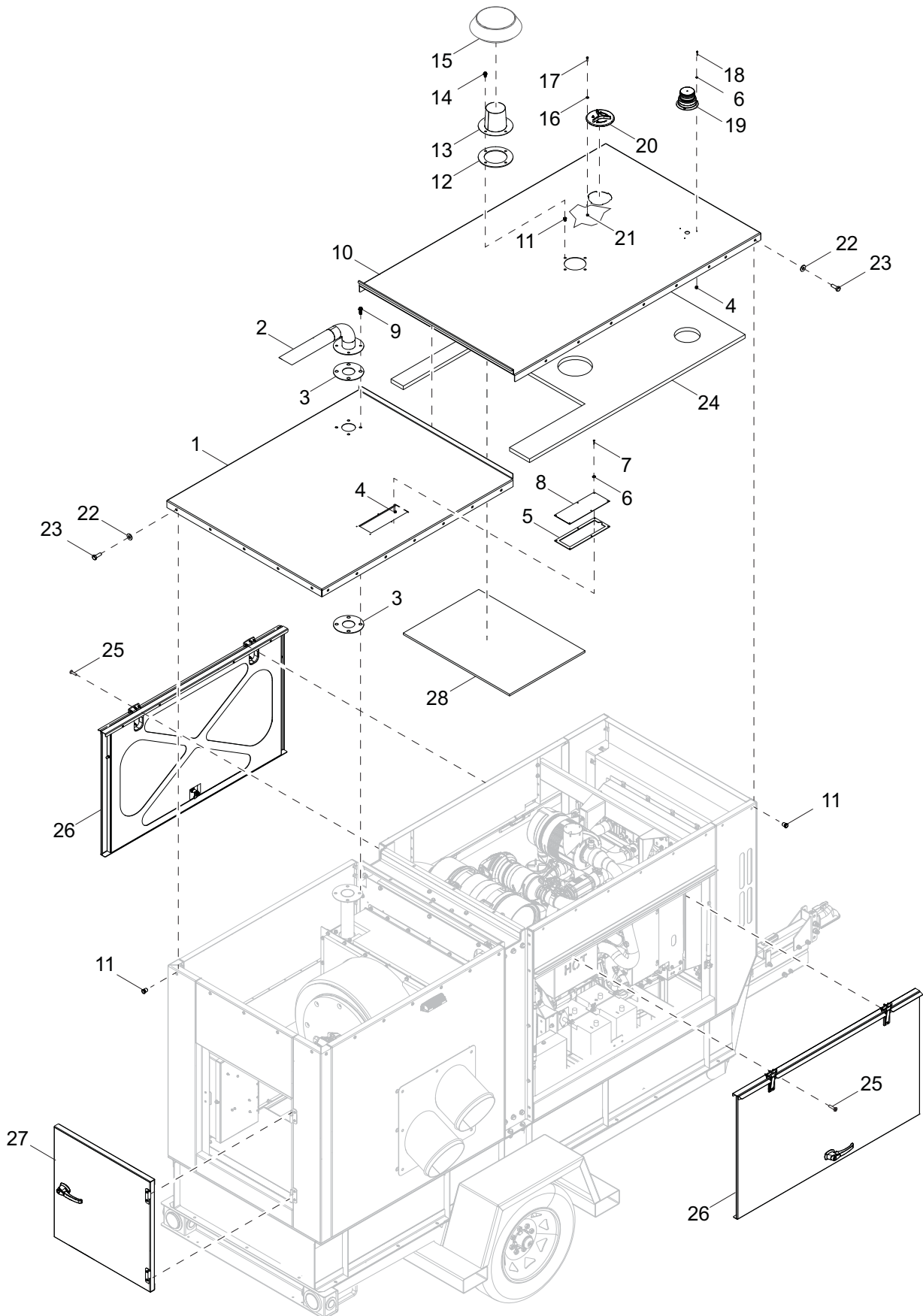

02897

ROOF AND DOORS TO UNIT

Item	Part No.	Qty	Description	Notes
1	10000044007	1	Panel, rear roof	
2	10000046098	1	Weldment, tail pipe	
3	A0000115159	2	Gasket, exhaust - high temp heater	
4	60270	9	Nut, 8-32 nylock, G6	
5	A0000195476	1	Gasket, .250 - foam	
6	62060	9	Washer, #8 flat .435/.060 - SS	
7	60695	6	Screw, 8-32 x 1.00 pan Phillips - SS	
8	A0000195522	1	Plate, ALB roof - no ZTR	
9	60202	4	Screw, M12-1.75 x 35 serrated flange hex, G10.9	
10	10000046605	1	Panel, front roof	
11	A0000186204	80	Nut, M10 x 1.50 insert	
12	A0000196406	1	Gasket, rain cap - rubber	
13	A0000069662	1	Weldment, rain cap extension	
14	60018	4	Screw, M10-1.50 x 20 serrated flange hex	
15	A0000069662	1	Rain cap	
16	61222	1	Washer, #10 sealing	
17	61180	1	Screw, 10-32 x .750 pan Phillips - SS	
18	60695	3	Screw, 8-32 x 1.00 pan Phillips -SS	
19	76176	1	Light, strobe 12V LED - amber	
20	0C2634	1	Cover, access	
21	60061	1	Nut, 10-32 nylock	
22	A0000206009	76	Washer, sealing .434ID x 1.00OD	
23	60177	80	Screw, M10-1.50 hex, G8.8	
24	10000047599	1	Foam, front roof	
25	35290	12	Screw, 10-24 x 1.00 flat head Phillips - SS	
26	10000030209	2	Assembly, forward door	
27	10000044032	1	Assembly, rear door	
28	10000047612	1	Foam, front roof	

FRONT ENCLOSURE PANELS TO UNIT

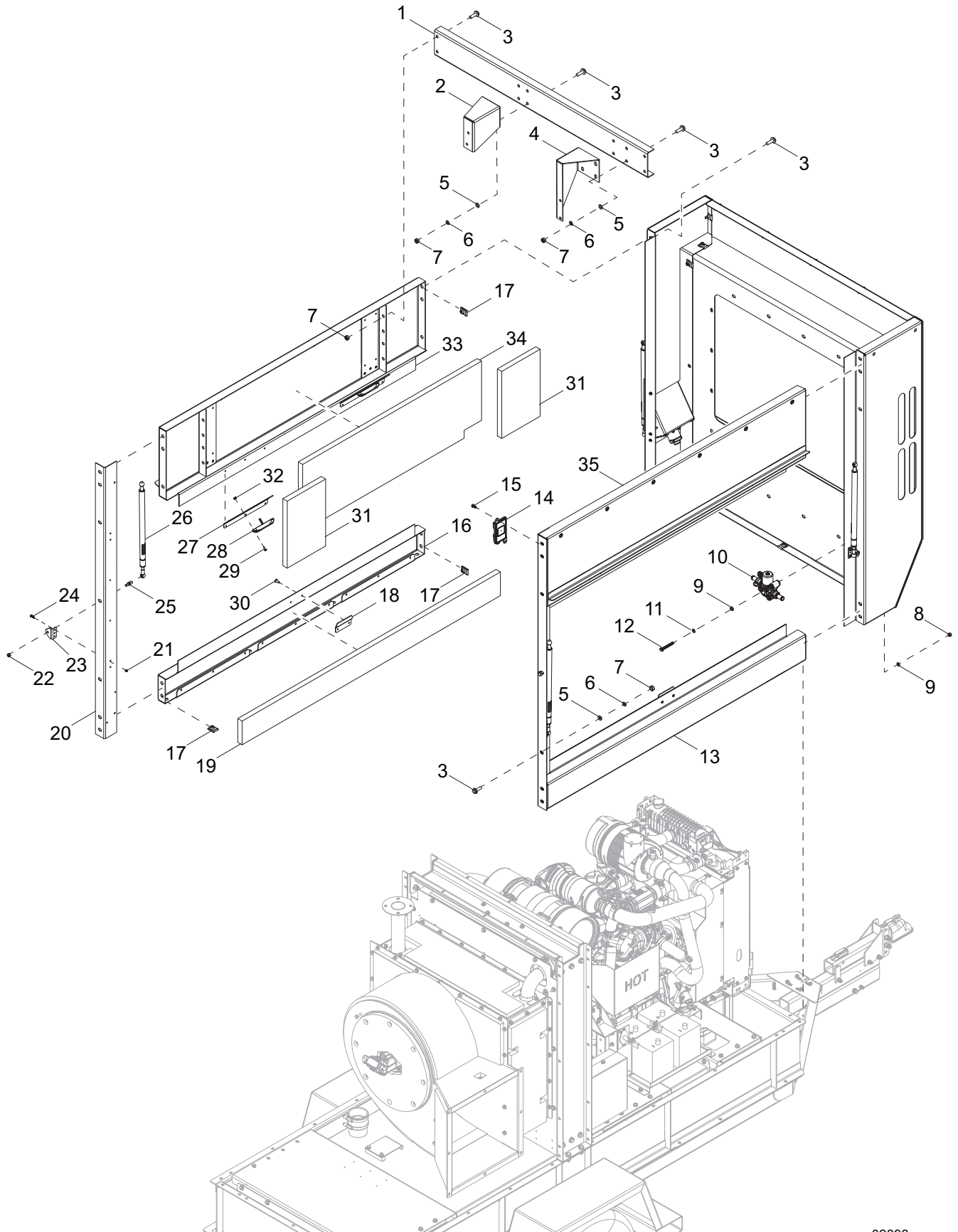

02898

FRONT ENCLOSURE PANELS TO UNIT

Item	Part No.	Qty	Description	Notes
1	10000047748	1	Brace, front cross - enclosure	
2	10000047729	1	Bracket, air cleaner mount	
3	60018	50	Screw, M10-1.50 x 20 serrated flange	
4	10000047709	1	Bracket, exhaust mount	
5	60027	50	Washer, M10 flat	
6	60026	50	Washer, M10 split lock	
7	60033	24	Nut, M10-1.50 hex, G8.8	
8	60032	3	Nut, M8-1.25 hex, G8.8	
9	60031	6	Washer, M8 flat	
10	A0000374752	1	Valve, exhaust - DEF	
11	60029	3	Washer, M8 split lock	
12	60074	3	Screw, M8-1.25 x 65 standard hex, G8.8	
13	A0000389584	2	Assembly, lower jamb	
14	A0000417615	1	Sensor, NOx	
15	63358	2	Screw, .250-20 x .625 hex/washer	
16	10000044015	2	Jamb, lower	
17	10000045773	26	Nut, M10 x 1.50 u-clip - short type	
18	A0000175229	2	Striker, plate - cam latch	
19	A0000389585	1	Foam, lower jamb	
20	10000044054	2	Jamb, rear vertical	
21	60038	6	Nut, M5-.80 nylock, G6	
22	60285	2	Nut, .312-18 hex, G2	
23	A0000032913	2	Bracket, mounting gas strut	
24	60156	6	Screw, M5-.80 x 16 pan Phillips, G4.8	
25	A0000032907	2	Ball stud, 13mm diameter - steel	
26	A0000032915	2	Strut, gas 10" stroke	
27	A0000199404	4	Bracket, LED mounting	
28	A0000212765	4	Assembly, interior LED light 12/24VDC	
29	60526	8	Screw, 8-32 x .500 pan Phillips, G2	
30	60260	24	Rivet, .188 diameter x .375 to .500 grip - SS	
31	A0000389595	4	Foam, upper jamb - small	
32	60270	8	Nut, 8-32 nylock, G6	
33	A0000176382	2	Weldment, upper jamb	
34	A0000389615	2	Foam, upper jamb - big	
35	A0000389616	2	Assembly, upper jamb	

REAR ENCLOSURE PANELS TO UNIT

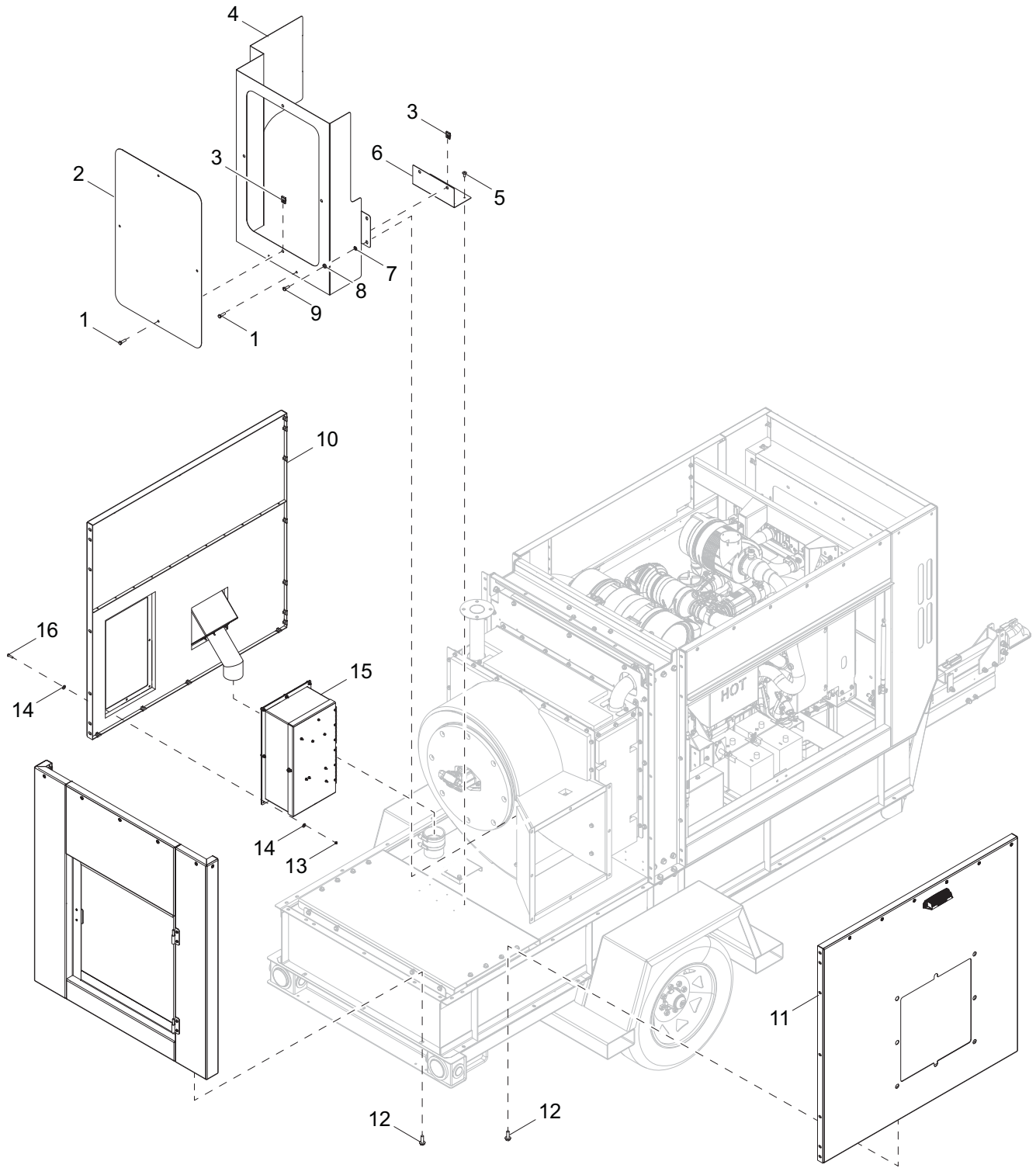

02899

REAR ENCLOSURE PANELS TO UNIT

Item	Part No.	Qty	Description	Notes
1	60055	6	Screw, M10-1.50 x 35 standard hex, G10.9	
2	A0000043916	1	Panel, hose wall	
3	10000045773	6	M10-1.50 U-clip -short type	
4	A0000043914	1	Hose wall	
5	60268	6	Rivet, .188 diameter x .126 to .250 grip - SS	
6	A0000043915	1	Bracket, hose wall	
7	60027	2	Washer, M10 flat	
8	60026	2	Washer, M10 split lock	
9	60177	2	Screw, M10-1.50 x 30 standard hex, G10.9	
10	A0000389627	1	Assembly, rear panel - left	
11	A0000389628	1	Assembly, rear panel - right	
12	60055	17	Screw, M10-1.50 x 35 standard hex, G10.9	
13	60047	8	Nut, M6-1.00 hex nylock, G8.8	
14	53336	16	Washer, M6-.250 flat	
15	A0000389641	1	Assembly, control box	
16	60335	8	Screw, M6-1.00 x 25 standard hex - SS	

ASSEMBLY - REAR ENCLOSURE PANELS

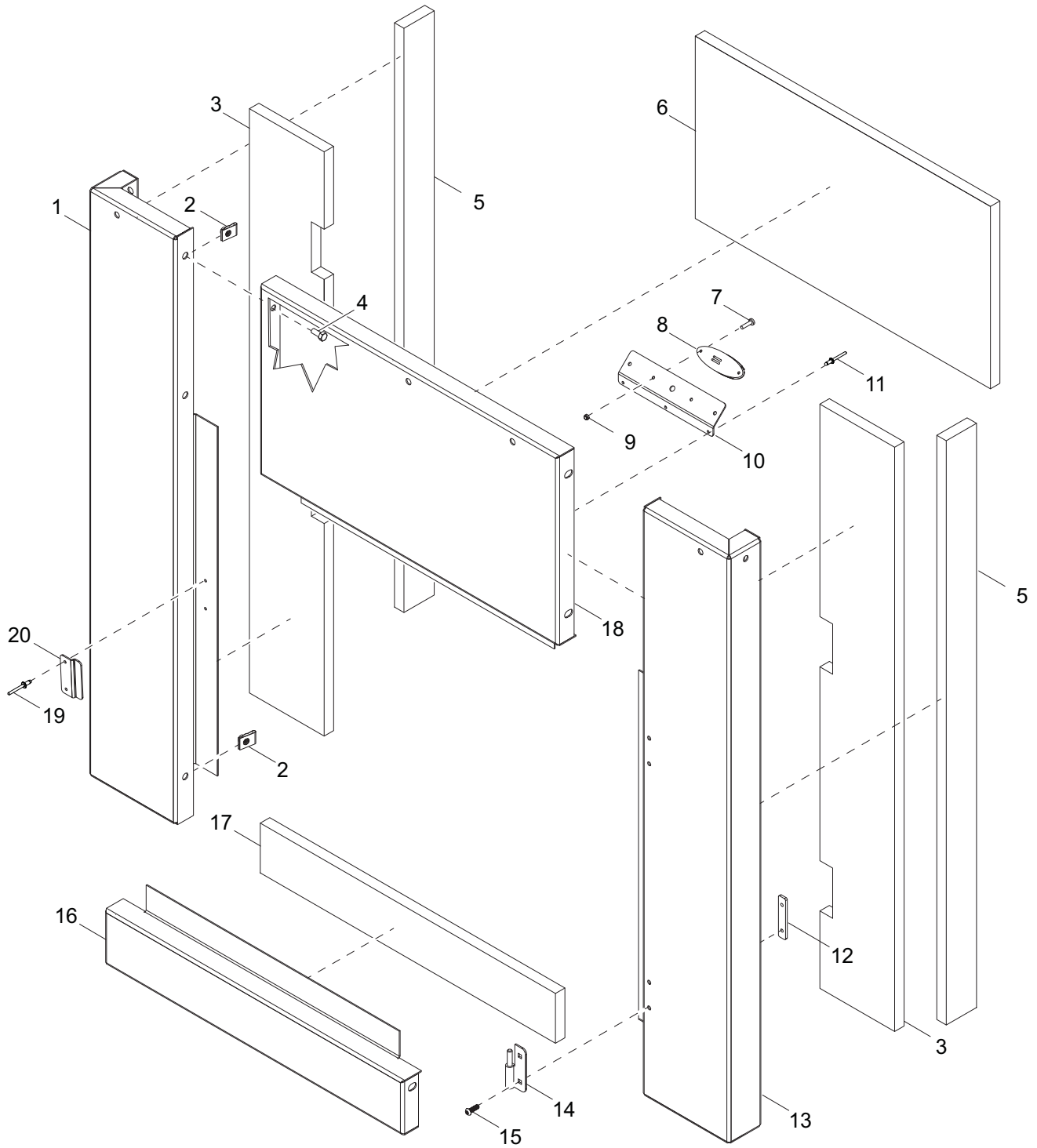

02799

ASSEMBLY - REAR ENCLOSURE PANELS

Item	Part No.	Qty	Description	Notes
1	10000044056	1	Corner, left	
2	10000045773	38	Nut, M10 x 1.5 u-clip short type	
3	A0000389645	2	Foam, corner - big	
4	10000046505	6	Screw, M10-1.5 x .25	
5	A0000389647	2	Foam, corner - small	
6	A0000389648	1	Foam, rear panel - top	
7	60526	2	Screw, 8-32 x .500 pan Phillips, G2	
8	A0000212765	1	Assembly, interior LED light, 12/24VDC	
9	60270	2	Nut, 8-32 nylock, G6	
10	A0000199404	1	Bracket, LED mount	
11	60260	5	Rivet, .188 diameter x .375 to .500 grip - SS	
12	10000011935	2	Plate, hinge back - threaded	
13	10000044031	1	Corner, right	
14	18461B	2	Hinge, left (male) - black	
15	63346	4	Screw, .312-18 x 1.00 security Torx - SS	
16	A0000181845	1	Rear panel - lower	
17	A0000389663	1	Foam, rear panel - lower	
18	A0000181843	1	Rear panel -upper	
19	A0000175229	1	Bracket, striker	

ASSEMBLY - REAR DOOR

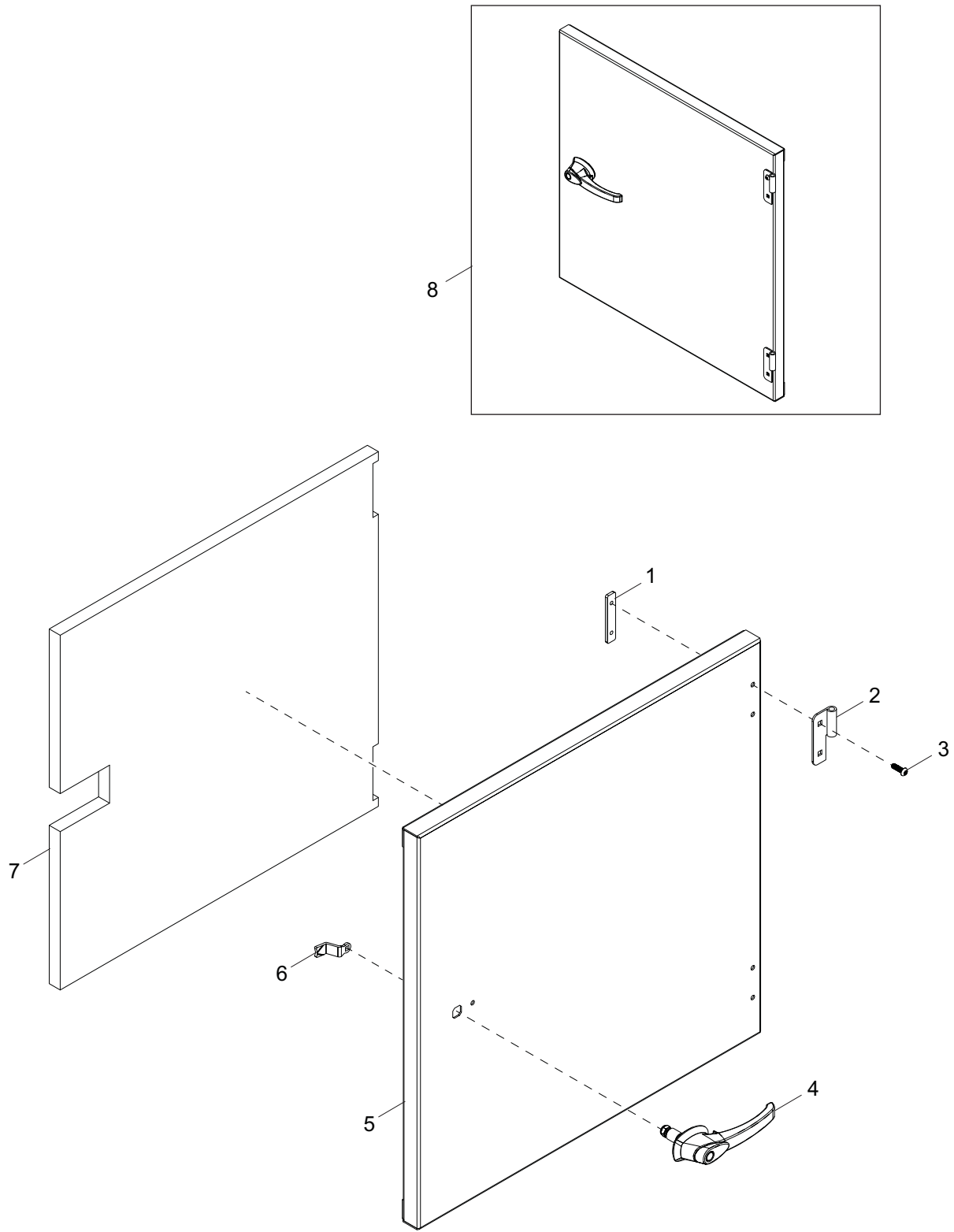

02900

ASSEMBLY - REAR DOOR

Item	Part No.	Qty	Description	Notes
1	10000011935	2	Plate, hinge back - threaded	
2	18459B	2	Hinge, right (male) - black	
3	63346	4	Screw, .312-18 x 1.00 security Torx - SS	
4	MAC3689	1	Handle, defeater - padlock only	
5	10000044047	1	Door - rear	
6	A0000175219	1	Cam, 24MM offset, 45mm long	
7	A0000389670	1	Foam, rear door	
8	A0000389567	1	Assembly, rear door	

ASSEMBLY - FRONT ENCLOSURE PANELS

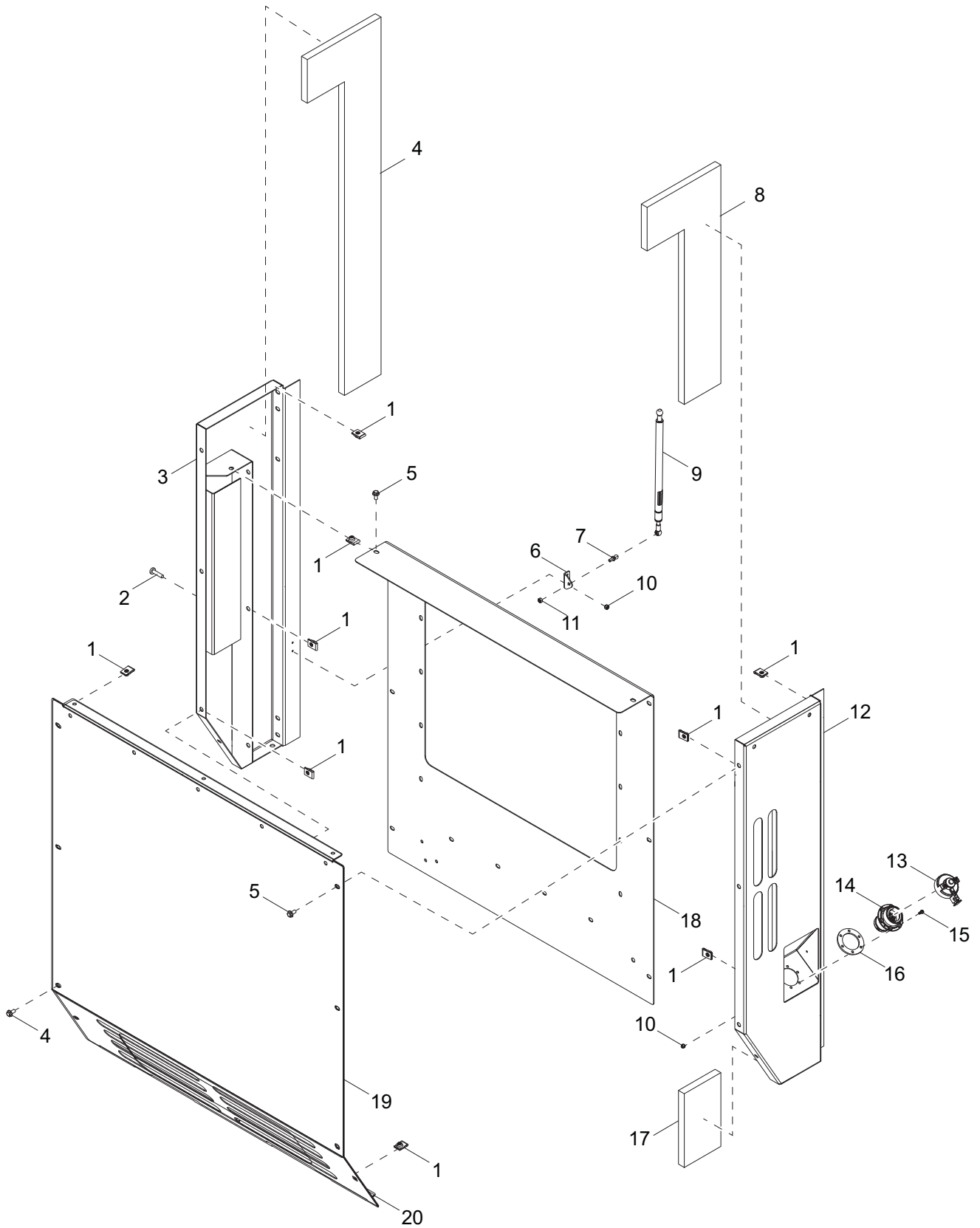

02901

ASSEMBLY - FRONT ENCLOSURE PANELS

Item	Part No.	Qty	Description	Notes
1	10000045773	22	Nut, M10 x 1.5 U-clip short type	
2	60156	4	Screw, M5-.80 x 16 pan Phillips, G4	
3	10000044014	1	Weldment, front jamb - right	
4	A0000389675	1	Foam, RH jamb	
5	60018	22	Screw, M10-1.50 x 20 serrated flange hex	
6	A0000032913	2	Bracket, mounting gas strut	
7	A0000032907	4	Ball stud, 13mm diameter - steel	
8	A0000389676	1	Foam, RH front jamb	
9	A0000032915	1	Gas strut, 10" stroke steel w/chromium plating	
10	60038	10	Nut, M5-.80 nylock, G6	
11	60285	4	Nut, .312-18 hex, G2	
12	10000044024	1	Weldment, front jamb - left	
13	A0000198703	1	Cap, DEF fill with lanyard	
14	54006	1	Adapter, DEF fill	
15	60037	6	Screw, M%-.80 x 20 pan Phillips, G4.8	
16	A0000389678	1	Gasket, DEF fill adapter	
17	A0000389679	1	Foam, front jamb down - left	
18	10000046243	1	Plate, louver backing	
19	10000043998	1	Panel, formed - front	
20	A0000171958	1	Panel, front - lower	

ASSEMBLY - FORWARD DOOR

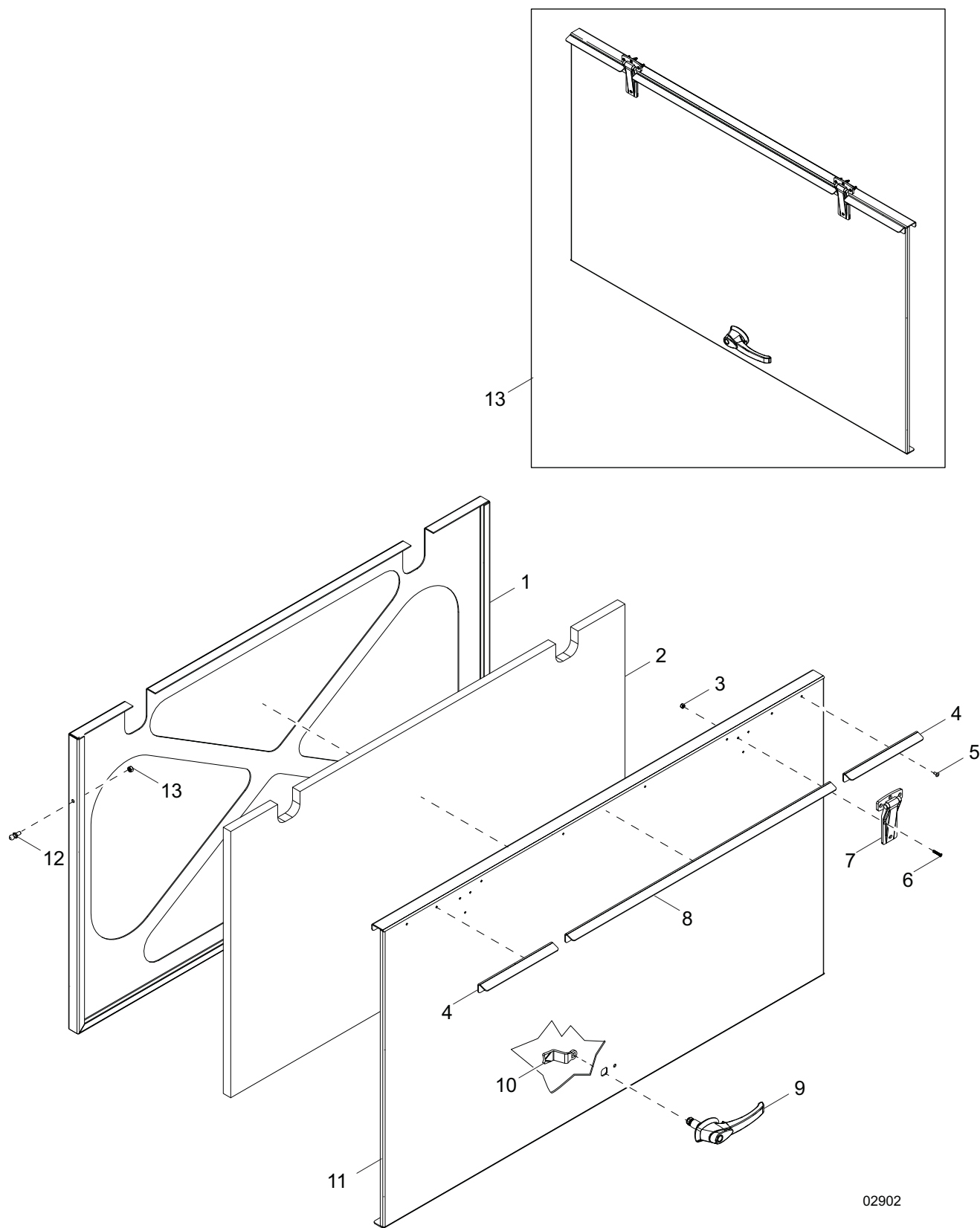

ASSEMBLY - FORWARD DOOR

Item	Part No.	Qty	Description	Notes
1	10000044070	1	Panel, door - interior	
2	A0000389690	1	Foam, front door	
3	60530	6	Nut, 10-24 nylock - SS	
4	A0000175468	2	Drip edge, flip up door - end	
5	60260	8	Rivet, .188 diameter x .375 to .50 grip - SS	
6	35290	6	Screw, 10-24 x 1.00 flat head Phillips - SS	
7	35136	2	Hinge, flush mount	
8	A0000175466	1	Drip edge, flip up door - middle	
9	MAC3689	1	Handle, defeater - padlock only	
10	A0000175219	1	Cam, 24MM offset, 45mm long	
11	10000044008	1	Panel, door - exterior	
12	A0000032907	2	Ball stud, 13MM diameter - steel	
13	60285	2	Nut, .312-18 hex, G2	
14	A0000389562	1	Assembly, forward door	

ASSEMBLY - REAR PANEL - LEFT

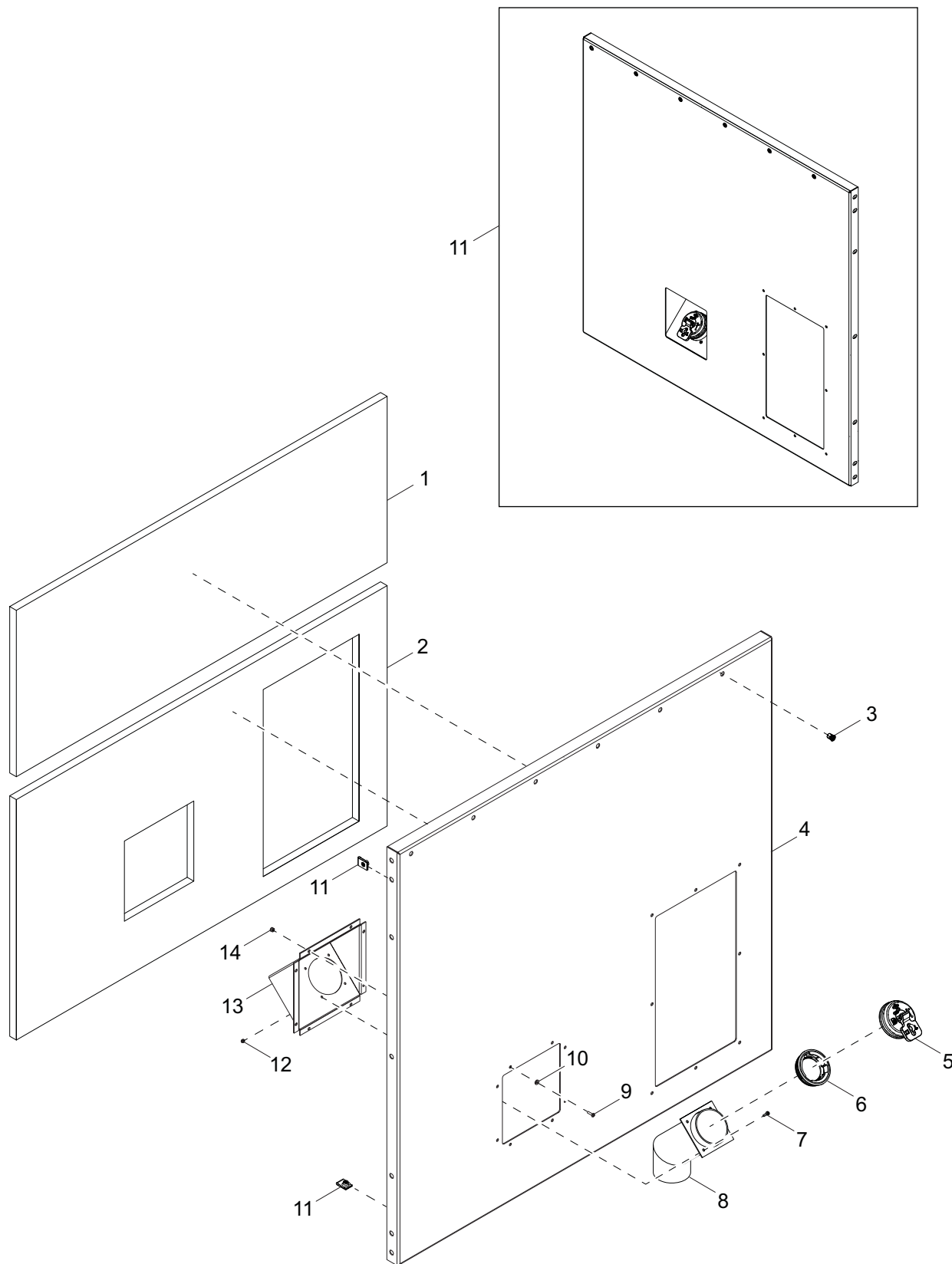

02903

ASSEMBLY - REAR PANEL - LEFT

Item	Part No.	Qty	Description	Notes
1	A0000389696	1	Foam, upper rear panel - left	
2	A0000389697	1	Foam, lower rear panel - left	
3	A0000186204	6	Nut, M10 x 1.50 insert	
4	A0000172138	1	Weldment, rear panel - left	
5	10000046498	1	Cap, fuel, venting lockable w/10 micron filter	
6	23830	1	Insert, fuel fill 3.50 inch - plastic	
7	60037	4	Screw, M5-0.80 x 20 pan Phillips, G4.8	
8	23710B	1	Weldment, 3.50 fuel neck fill - black	
9	61180	8	Screw, 10-32 x .750 pan Phillips, G4.8	
10	61222	8	Washer, #10 sealing	
11	10000045773	19	Nut, M10 x 1.50 U-clip - short type	
12	60038	4	Nut, M5-.080 nylock, G6	
13	23697B	1	Panel, fuel inlet	
14	61045	8	Nut, 10-32 serrated flange	
15	A0000389627	1	Assembly, rear panel - left	

ASSEMBLY - EXHAUST PANEL

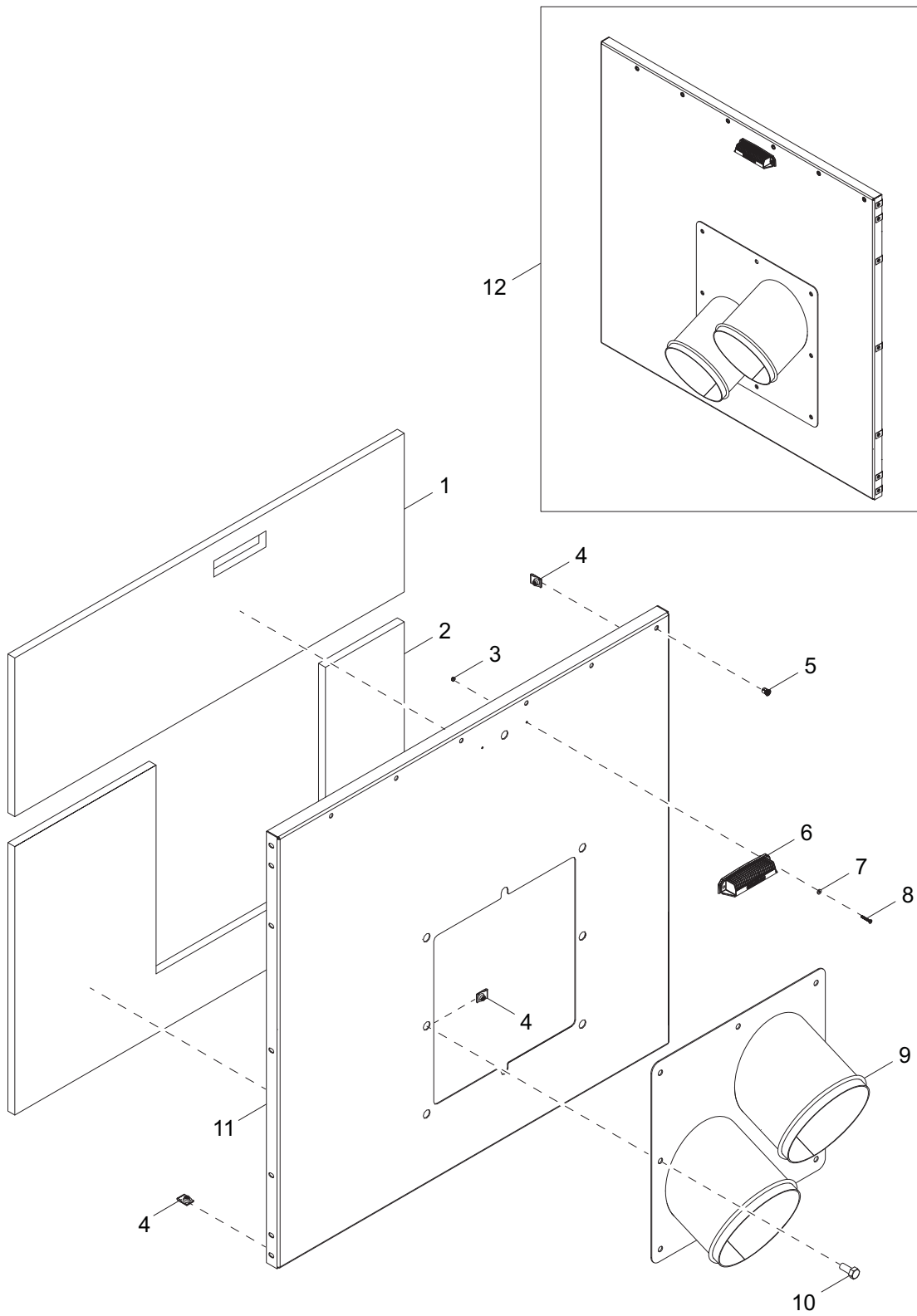

02904

ASSEMBLY, EXHAUST PANEL

Item	Part No.	Qty	Description	Notes
1	A0000389699	1	Foam, upper rear panel - right	
2	A0000389701	1	Foam, lower rear panel - right	
3	60061	2	Nut, 10-32 nylock	
4	10000045773	21	Nut, M10 x 1.50 U-clip - short type	
5	A0000186204	6	Nut, M10 x 1.50 insert	
6	A0000212767	1	Assembly, LED light 12/24	
7	61222	2	Washer, #10 sealing	
8	63308	2	Screw, 10-32 x 1.25 pan Phillips - SS	
9	A0000165709	1	Weldment, discharge 12 inch dual	
10	60177	8	Screw, M10-1.50 x 30 standard hex, G10.9	
11	A0000181549	1	Weldment, rear panel - right	
12	A0000389628	1	Assembly, rear panel - right	

ASSEMBLY - CONTROL BOX

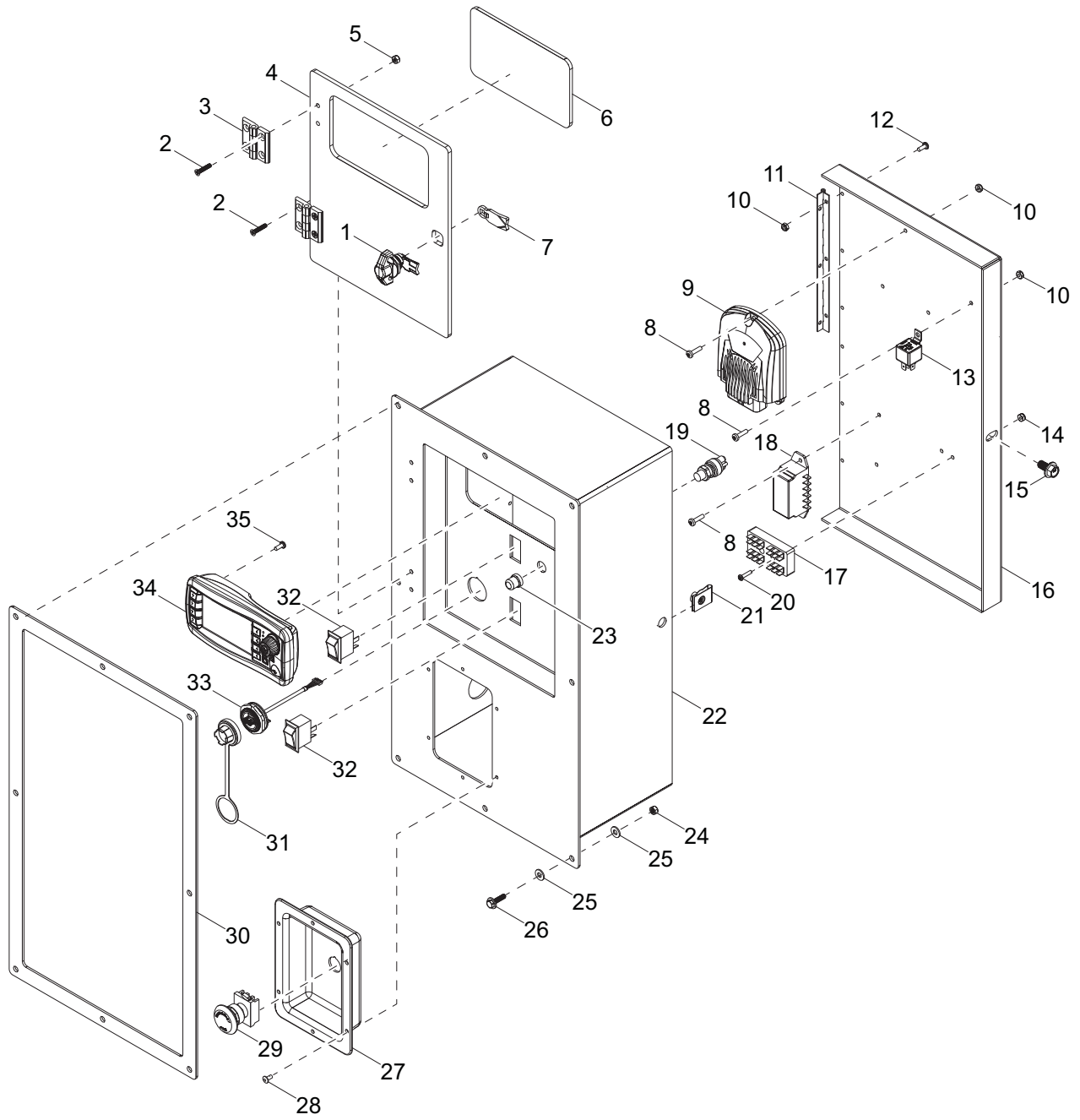

02905

ASSEMBLY - CONTROL BOX

Item	Part No.	Qty	Description	Notes
1	MAC3687	1	Wing knob, 1/4 turn pad lockable - black	
2	35290	8	Screw, 10-24 x 1.00 flat head Phillips - SS	
3	35394	2	Hinge, door - small	
4	A0000150607	1	Door, control box	
5	60530	8	Nut, 10-24 nylock - SS	
6	A0000149679	1	Window, control door	
7	MAC3688	1	Cam, single point	
8	60062	6	Screw, 10-32 x .750 pan Phillips, G2	
9	10000040911	1	Control unit, EPEC 3606	
10	60277	12	Screw, 10-32 x .500 pan Phillips, G2	
11	10784	2	Hinge, piano 9.00"	
12	60061	18	Nut, 10-32 nylock	
13	67028	1	Relay, 24V 30/40A N.O. w/diode	
14	60270	2	Nut, 8-32 nylock, G6	
15	60018	1	Screw, M10-1.50 x 20 serrated flange hex,	
16	A0000150605	1	Door, control box - back	
17	66992	1	Block, terminal 4 x 6 - push-on	
18	A0000213589	1	Fuse holder, 6 bank ATM mini - push-on	
19	10000047116	1	Switch, momentary	
20	60694	2	Screw, 8-32 x .750 pan Phillips - SS	
21	10000045773	1	Nut, M10-1.5 u-clip - short type	
22	A0000150609	1	Weldment, control box	
23	10000047106	1	Assembly, boot nut	
24	60047	8	Nut, M6-1.00 nylock hex, G8.8	
25	53336	16	Washer, M6-.250 flat	
26	60335	8	Screw, M6-1.00 x 25 standard hex, SS	
27	30645	1	Panel, emergency stop	
28	60268	6	Rivet, .188 diameter x .126 to .250 grip - SS	
29	65470	1	Switch, e-stop operator	
30	A0000149488	1	Gasket, control box	
31	A0000150028	1	Cap, USB connector - external	
32	66995	2	Switch, rocker DPST, on-off	
33	A0000150028	1	Connector, USB - external	
34	10000040934	1	Screen, HMI Opus A3	
35	60044	4	Screw, M5-.80 x 12 pan Phillips, G4.8	

AIR TO AIR EXCHANGE ASSEMBLY

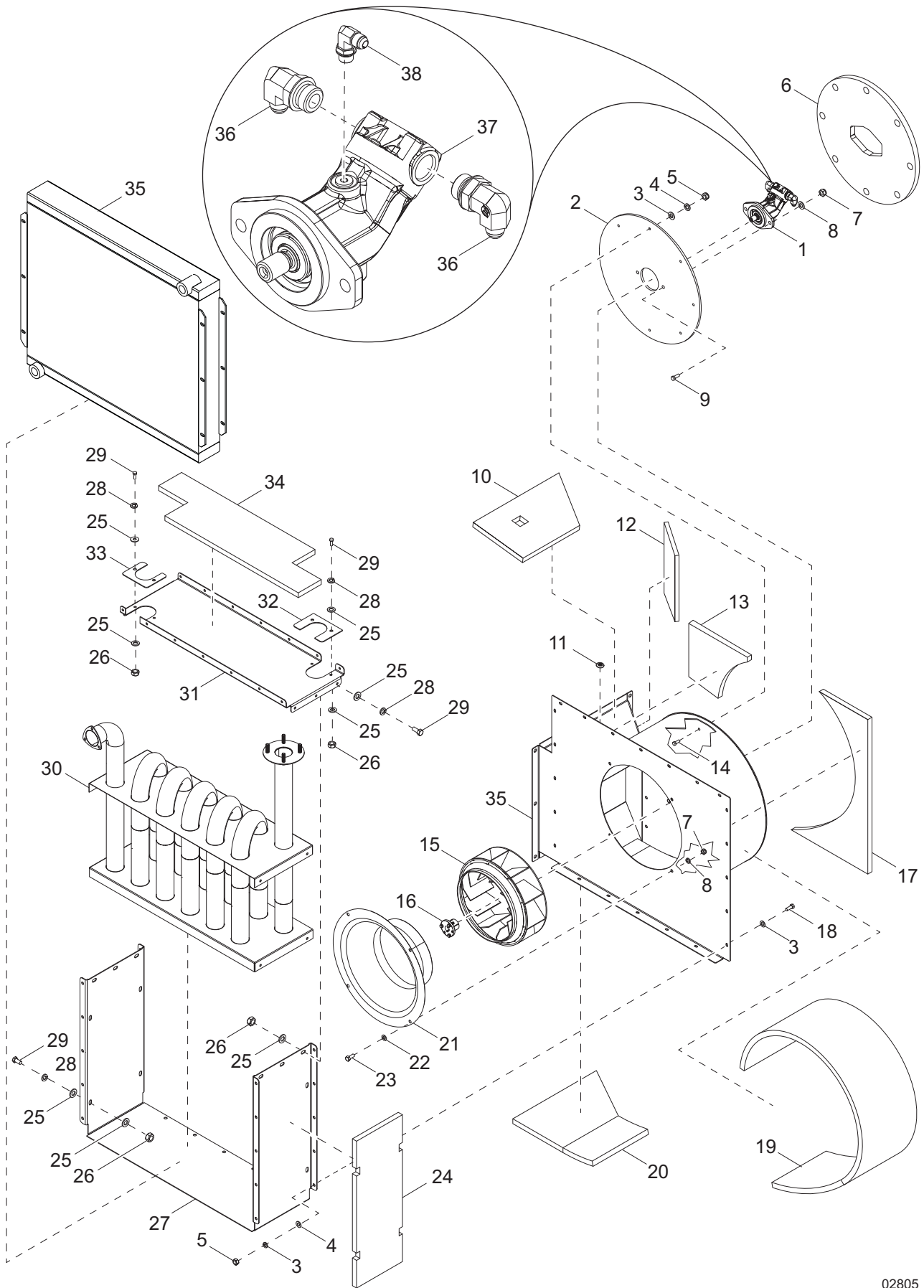

02805

AIR TO AIR EXCHANGE ASSEMBLY

Item	Part No.	Qty	Description	Notes
1	10000041452	1	Assembly, bent axis hydraulic motor	
2	10000032082	1	Plate, fan motor - machined	
3	60027	40	Washer, M10 flat	
4	60026	20	Washer, M10 split lock	
5	60033	8	Nut, M10-1.50 hex, G8.8	
6	A0000390288	1	Foam, scroll motor plate	
7	60681	6	Nut, .500-13 hex - SS	
8	60702	6	Washer, .500 split lock - SS	
9	60830	2	Screw, .500-10 x 1.75 standard hex - SS	
10	A0000390281	1	Foam, heat exchanger - top	
11	MAC2356	1	Flange, .250 NPT	
12	A0000390275	1	Foam, heat exchanger - side	
13	A0000390267	1	Foam, scroll corner - top right - rear	
14	60177	8	Screw, M10-1.50 x 30 standard hex, G10.9	
15	A0000164763	1	Fan, BCPL 182	
16	A0000417659	1	Bushing, split taper	
17	A0000390262	1	Foam, scroll - left - rear	
18	35801	12	Screw, M10-1.50 x 25 standard hex, G10.9	
19	A0000390261	1	Foam, scroll - rear	
20	A0000390260	1	Foam, heat exchanger - bottom	
21	MAC3564	1	Inlet cone, medium platform	
22	62261	4	Washer, .500 flat .875/.063 - SS	
23	61190	4	Screw, .500-13 x 1.00 standard hex - SS	
24	A0000390258	2	Foam, heat exchanger sides	
25	35275	36	Washer, flat .375 .820/.057	
26	60140	18	Nut, .375-16 hex, G5	
27	10000035622	1	Bottom, air-air chamber	
28	60206	12	Washer, .375 split lock	
29	60205	15	Screw, .375-16 x 1.00 standard hex, G5	
30	10000035737	1	Weldment, air-to-air flame-less	
31	A0000166901	1	Chamber, air-air top	
32	10000035850	1	Cover, flame-less exhaust hole	
33	10000043179	1	Cover, flame-less exhaust hole	
34	A0000390254	1	Foam, heat exchanger top	
35	10000036350	1	Weldment, scroll	
36	A0000390251	2	Fitting, 90° elbow	
37	10000041024	1	Motor, bent axis - hydraulic	
38	A0000368140	1	Fitting, 90° elbow	

HYDRAULIC TANK ASSEMBLY

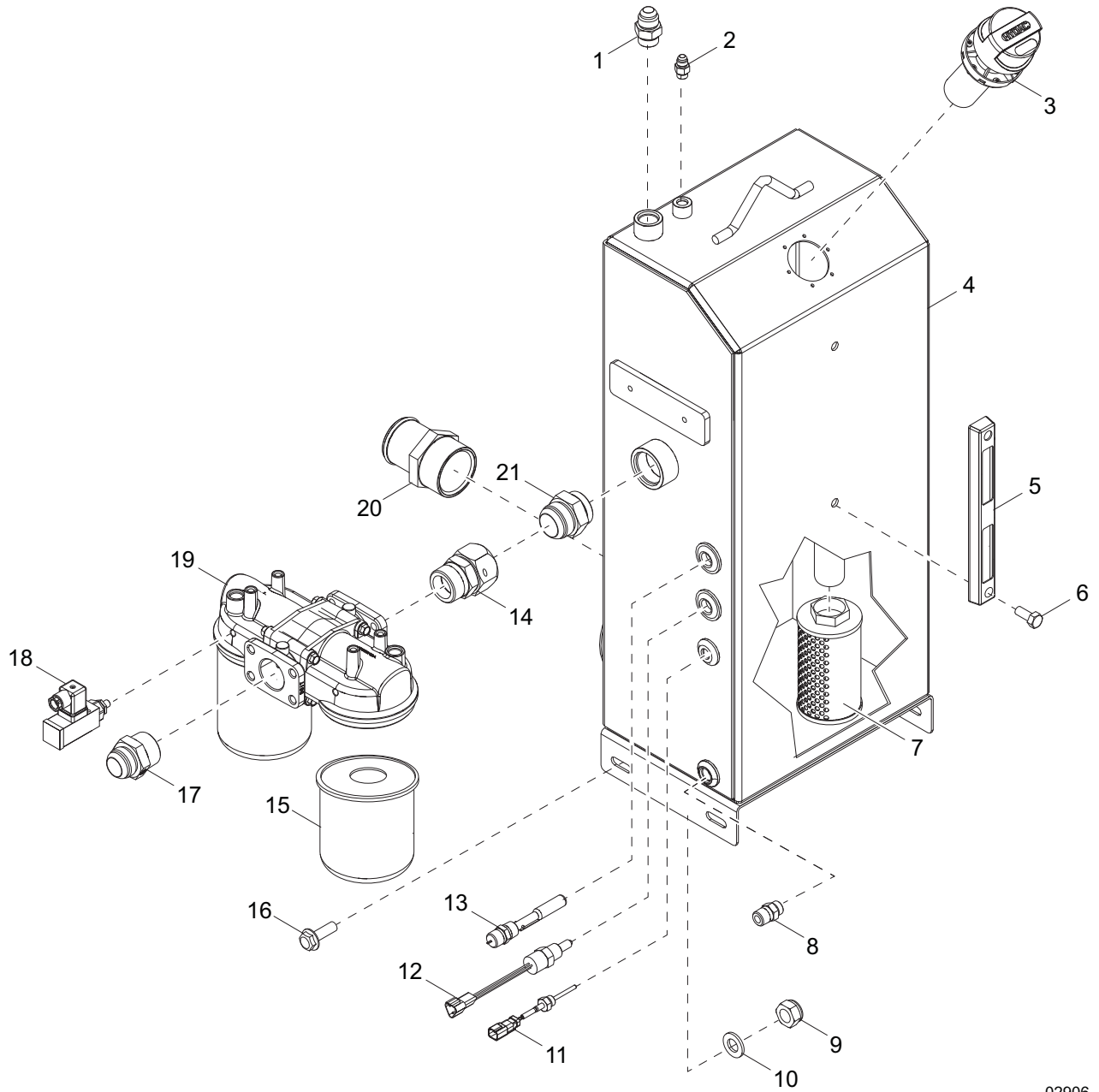

02906

HYDRAULIC TANK ASSEMBLY

Item	Part No.	Qty	Description	Notes
1	A0000382850	1	Adapter, straight	
2	A0000382855	1	Adapter, straight	
3	A0000374746	1	Filler, breather filter	
4	A0000382864	1	Weldment, reservoir	
5	A0000374755	1	Indicator / switch. tank level	
6	60205	2	Screw, .375-16 x 1.00 standard hex, G5	
7	A0000374757	1	Diffuser, hydraulic	
8	A0000072045	1	Adapter, straight .500NPT x .500ORB	
9	60305	4	Nut, M12-1.75 nylock, G8.8	
10	60012	4	Washer, M12 flat	
11	10000047135	1	Sensor, temperature	
12	A0000373986	1	Switch, temperature - hydraulic	
13	A0000373728	1	Switch, level	
14	A0000382885	1	Adapter, straight MP-FJS	
15	A0000389486	1	Filter, 7 micron	
16	60202	4	Screw, M12-1.75 x 35 serrated flange hex, G10.9	
17	A0000382885	1	Adapter, straight MP-FJS	
18	A0000374754	1	M-IC/M-NPT, straight	
19	A0000373735	2	Assembly, filter head	includes item 15
20	A0000382906	1	Barb, hose to male NPT, straight	
21	A0000368146	1	Fitting, nipple	

HYDRAULIC HEAT MANIFOLD ASSEMBLY

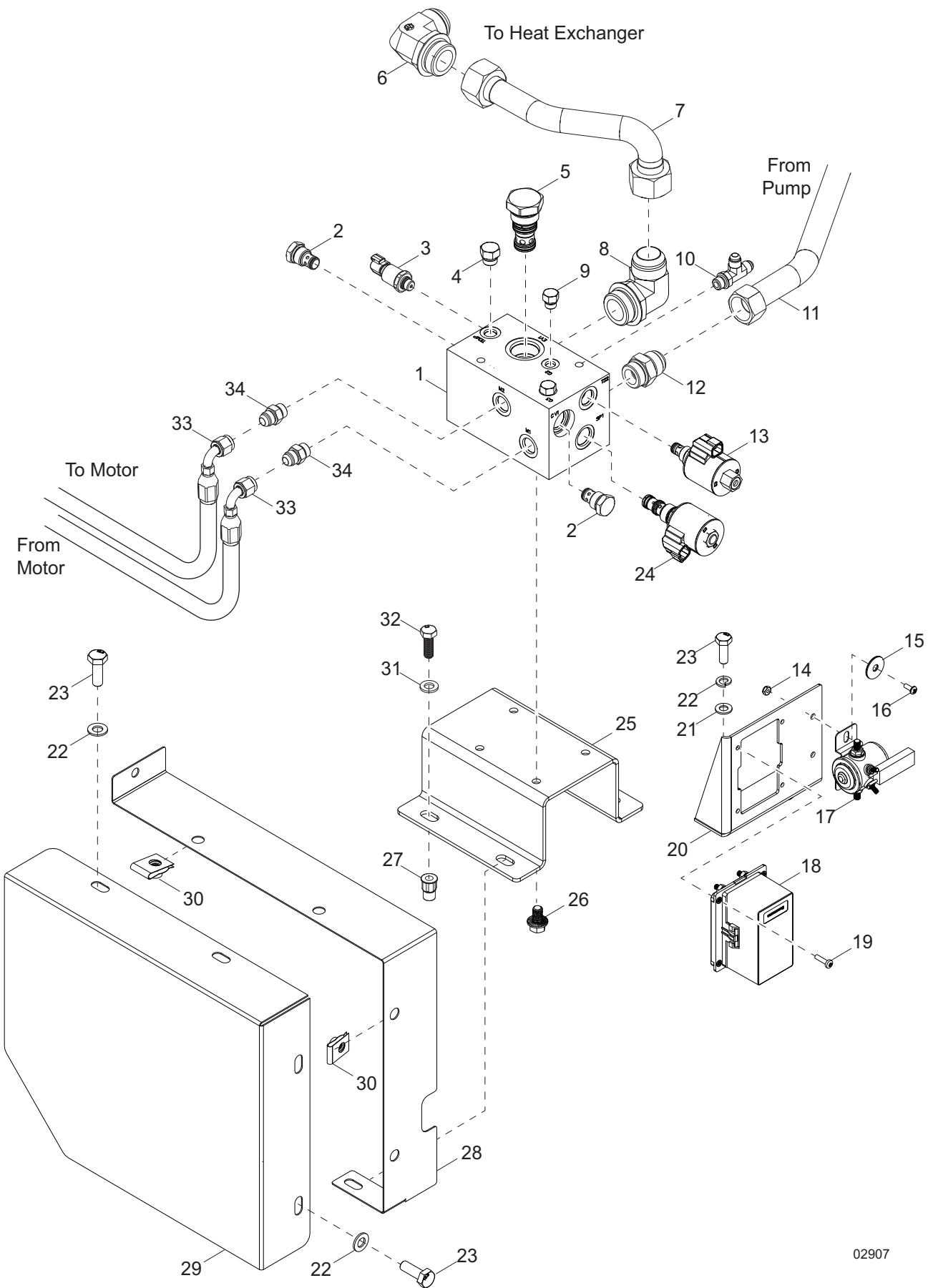

02907

HYDRAULIC HEAT MANIFOLD ASSEMBLY

Item	Part No.	Qty	Description	Notes
1	A0000390371	1	Manifold, hydraulic (bare block)	
2	A0000390356	1	Check valve, CV10-20-0-V-05	
	A0000390358	1	Check valve, CV10-20-0-V-70	
3	A0000390348	1	Sensor, hydraulic pressure	
4	A0000390404	1	Plug, hydraulic	
5	A0000390346	1	Valve, directional control	
6	A0000417575	1	Fitting, 90°	
7	A0000076817	1	Assembly, hydraulic cooler inlet hose	
8	A0000390552	1	6801-20-20	
9	A0000390551	2	Plug, hydraulic	
10	A0000390413	1	6804-06-06-06	
11	10000042845	1	Assembly, hydraulic oil cooler inlet hose	
12	A0000390554	1	6400-20-20	
13	A0000390318	1	Valve, proportional relief	
14	60415	2	Nut, 10-32 nylock - SS	
15	60452	2	Washer, .312 flat 1.125/1.00 - SS	
16	60398	2	Screw, 10-32 x .500 pan Phillips - SS	
17	A0000211170	1	Assembly, solenoid relay w/diode	
18	73094	1	RMTR, Bussman	
19	60062	4	Screw, 10-32 x .750 pan Phillips, G2	
20	A0000206658	1	Bracket, fuse box	
21	60027	2	Washer, M10 flat	
22	60026	2	Washer, M10 split lock	
23	60177	2	Screw, M10-1.50 x 30 standard hex, G10.9	
24	A0000390377	1	Valve, proportional flow control	
25	10000058007	1	Mount, manifold	
26	60451	4	Screw, .375-16 x .625 flange hex	
27	10000045480	4	Rivnut, M12-1.75	
28	A0000168378	1	Bracket, manifold shield	
29	A0000168348	1	Shield, manifold	
30	10000045773	4	Nut, m10 x 1.50 U-clip - short type	
31	60012	4	Washer, M12 flat	
32	G053607	4	Screw, M12-1.75 x 35 HHC, G8.8	
33	A0000039617	2	Assembly, fan motor hose	
34	A0000072485	2	Connector, straight -8 (.500)M 37° flare	

ASSEMBLY - DEF TANK AND RADIATOR SHROUD

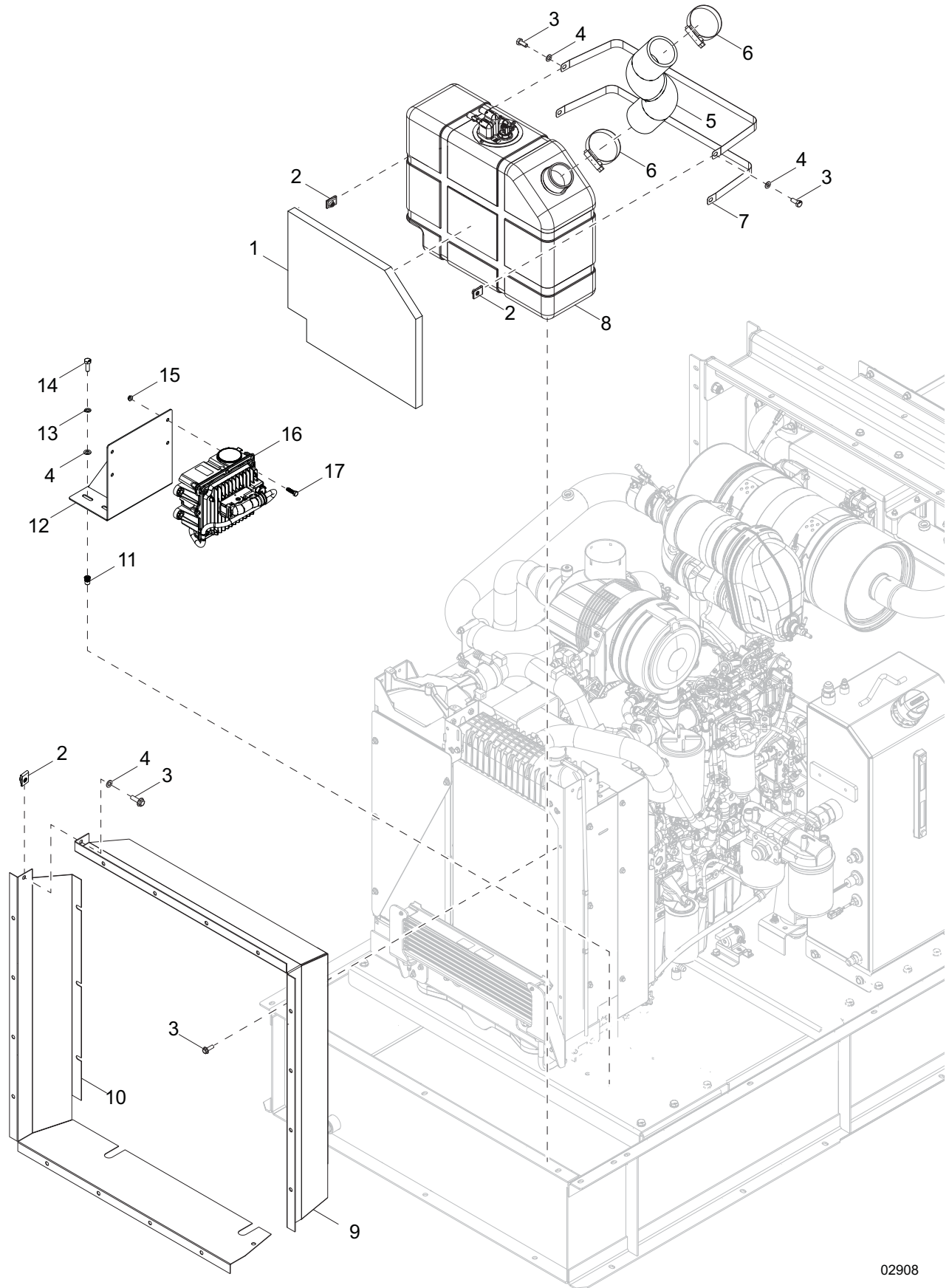

02908

ASSEMBLY - DEF TANK AND RADIATOR SHROUD

Item	Part No.	Qty	Description	Notes
1	A0000206808	1	Spacer, foam DEF tank	
2	10000045773	6	Nut, M10 x 1.5 U-clip short type	
3	60018	10	Screw, M10-1.50 x 20 serrated flange	
4	60027	8	Washer, M10 flat	
5	A0000198888	1	Hose, DEF fill, top	
6	60316	2	Clamp, hose SAE 032 (1.56 -2.50)	
7	10000046700	2	Strap, DEF tank	
8	10000046574	1	Assembly, DEF tank	
9	A0000024147	1	Shroud, radiator - left	
10	A0000024148	1	Shroud, radiator - right	
11	A0000163057	4	Rivnut, M10-1.5 x 3.8-7.9 thick - metal	
12	A0000152639	1	Weldment, PEU bracket	
13	60026	4	Washer, M10 split lock	
14	60177	4	Screw, M10-150 x 30 standard hex, G10.9	
15	60020	4	Nut, M8-1.25 serrated flange, G8.8	
16	A0000390576	1	Pump, DEF	
17	63168	4	Screw, M8-1.25 x 30 standard hex, G10.9	

ASSEMBLY - COOLING SYSTEM

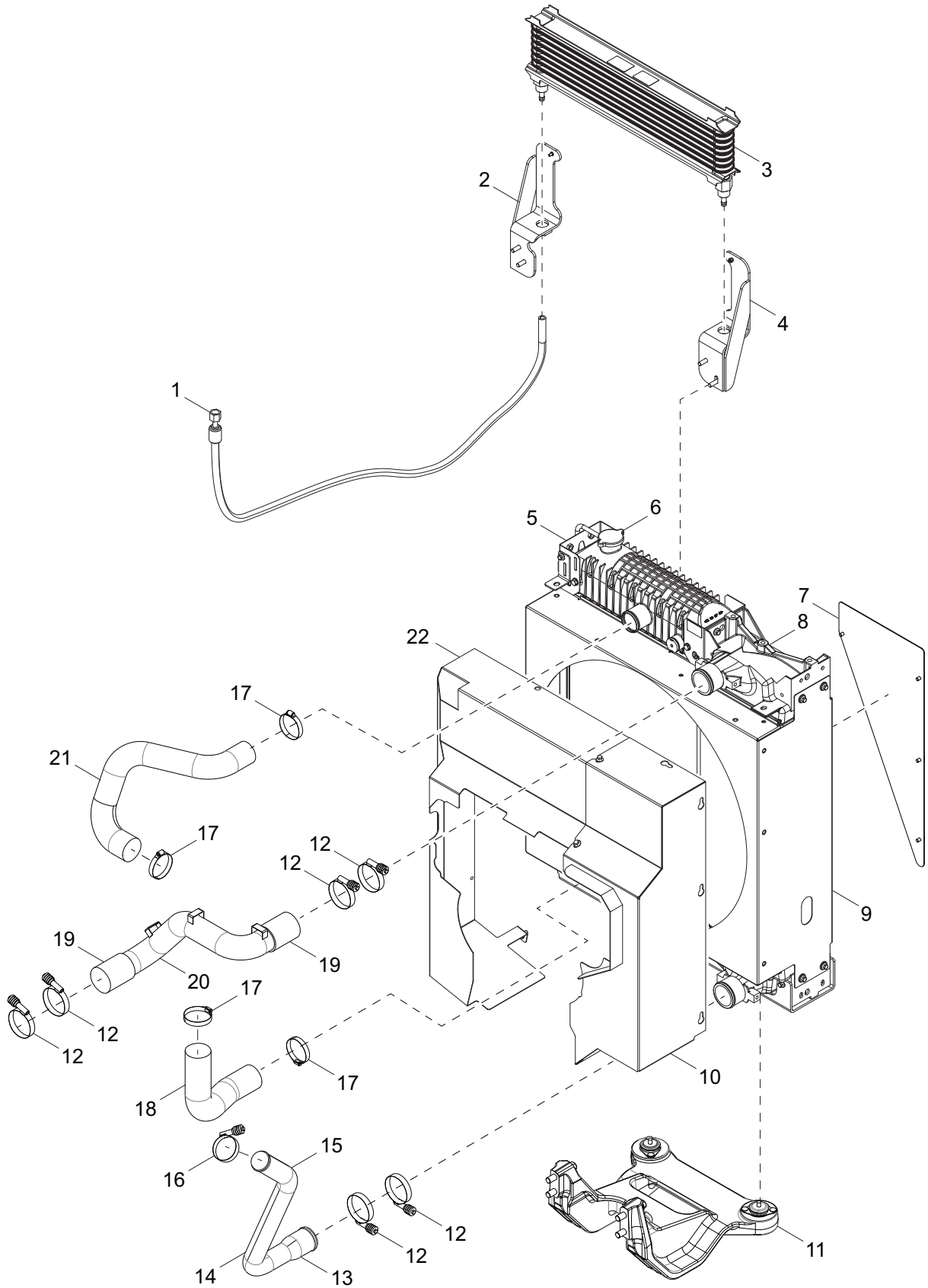

02915

ASSEMBLY - COOLING SYSTEM

Item	Part No.	Qty	Description	Notes
1	A0000417592	1	Hose, fuel cooler	
2	A0000417596	1	Bracket, fuel cooler - left	
3	A0000417589	1	Cooler, fuel	
4	A0000417597	1	Bracket, fuel cooler - right	
5	A0000417599	1	Radiator,	
6	A0000417602	1	Cap, radiator	
7	A0000415528	1	Panel, radiator	
8	A0000417601	1	Charge cooler	
9	A0000417603	1	Shroud, radiator	
10	A0000415527	1	Guard, radiator - right	
11	A0000415517	1	Bracket, radiator	
12	A0000415542	6	Clamp, upper air	
13	A0000414862	1	Hose, upper air coupler	
14	A0000415543	1	Pipe, lower air	
15	A0000417609	1	Hose, lower air	
16	A0000415557	1	Clamp, lower air	
17	A0000417611	4	Clamp, radiator hose	
18	A0000390721	1	Hose, lower radiator	
19	A0000414862	2	Hose, upper air coupler	
20	A0000415538	1	Pipe, upper air	
21	A0000390719	1	Hose, upper radiator	
22	A0000415524	1	Guard, radiator - left	

ENGINE ASSEMBLY

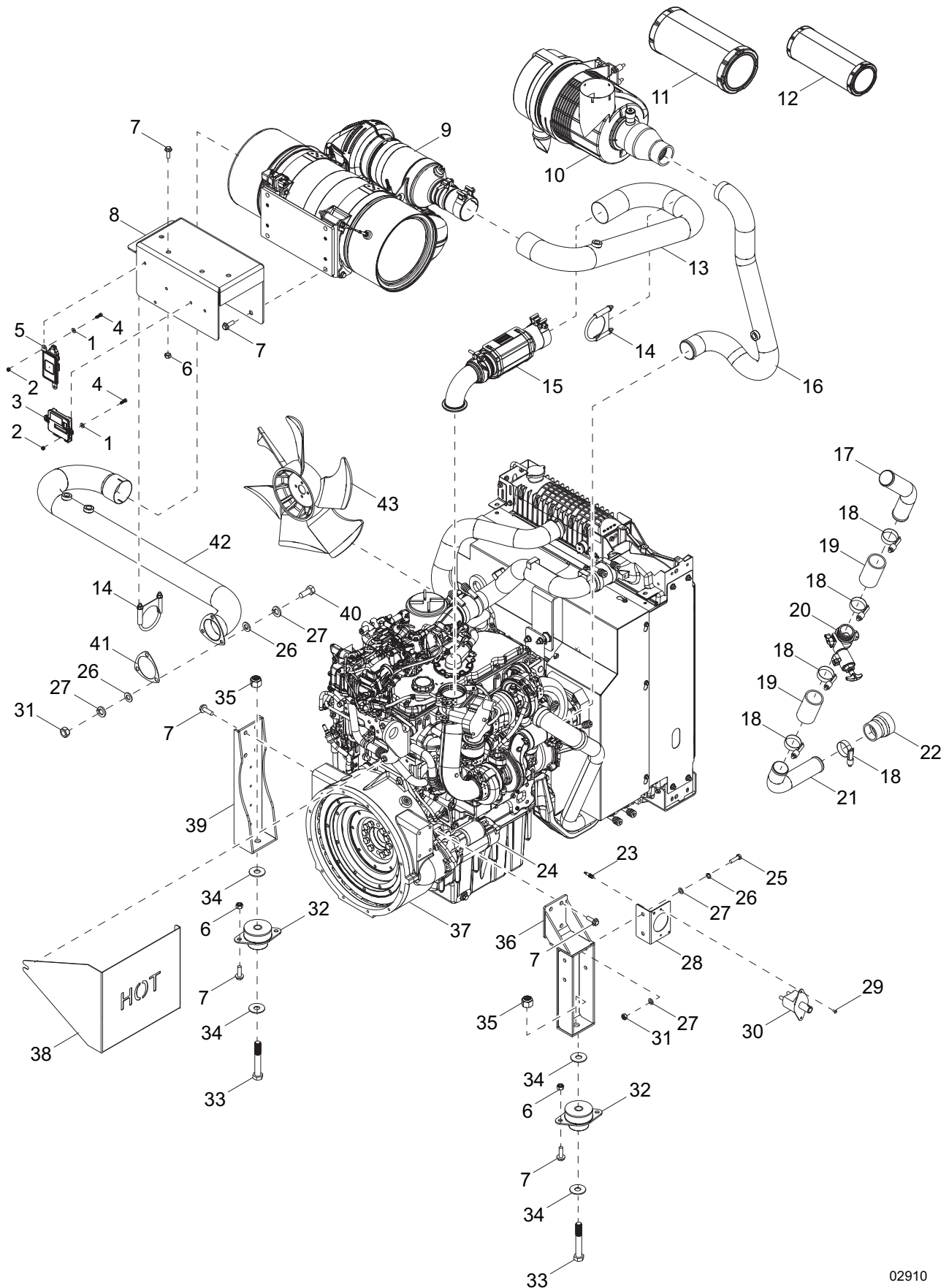

02910

ENGINE ASSEMBLY

Item	Part No.	Qty	Description	Notes
1	53336	4	Washer, M6-.250 flat	
2	60047	4	Nut, M6-1.00 nylock hex, G8.8	
3	A0000390604	1	Sensor, NH3 G22	
4	60223	4	Screw, M6-1.00 x 20 standard hex, G4.8	
5	A0000390603	1	Sensor, NOX G22	
6	60305	4	Nut, M12-1.75 nylock, G8.8	
7	60202	8	Screw, M12-1.75 x 35 serrated flange hex, G10.9	
8	10000048011	1	Bracket, after-treatment mount	
9	A0000390574	1	Module, clean emission	
10	A0000390600	1	Assembly, air housing	
11	A0000089804	1	Element, air filter - primary	
12	A0000089808	1	Element, air filter - safety	
13	10000047927	1	Weldment, exhaust 3.00" OD	
14	18821	2	Clamp, muffler 3.00"	
15	A0000390599	1	Pipe, flexible exhaust	
16	10000047965	1	Weldment, intake tube, 2.50 " OD	
17	A0000019438	1	Pipe, intake 2.00" OD turbo to PAS	
18	60660	5	Clamp, hose - constant torque - 1.75-2.625	
19	28540	2	Hose, CAC 2.00" x 4.00" long	
20	A0000019099	1	Valve, PAS 2.00" diameter ESD-24V	
21	A0000019442	1	Pipe, intake 2.00" OD PAS to CAC - in	
22	A0000019445	1	Reducer, CAC 2.00" ID to 2.50" ID x 3.00 long	
23	0E7329B	1	Light, pilot 8MM amber - LED	
24	A0000338537	1	Starter	
25	60055	2	Screw, M10-1.50 x 35 standard hex, G10.9	
26	60027	7	Washer, M10 flat	
27	60026	7	Washer, M10 split lock	
28	A0000058014	1	Bracket, battery disconnect switch	
29	60268	2	Rivet, .188 diameter x .126 to .250 grip	
30	21489	1	Switch, battery disconnect - 500A continuous	
31	60033	5	Nut, M10-1.50 hex, G8.8	
32	10000047352	2	Vibration mount - shock	
33	53157	2	Screw, .750-10 x 5.50 standard hex, G8	
34	60247	4	Washer, .750 flat 2.020/.130	
35	60584	2	Nut, .750-10 nylock, G5	
36	10000170841	1	Weldment, engine support - right	
37	10000045508	1	Engine D4.4L	incl. cooling system
38	A0000115504	1	Heat guard, turbo	
39	10000170840	1	Weldment, engine support - left	
40	A0000206625	3	Screw, M10-1.50 x 25 HHC, G10.9	
41	MAC3831	1	Gasket, exhaust 3.00"	
42	10000046419	1	Weldment, exhaust pipe 3.00" OD	
43	A0000415507	1	Fan, engine	

PUMP ASSEMBLY

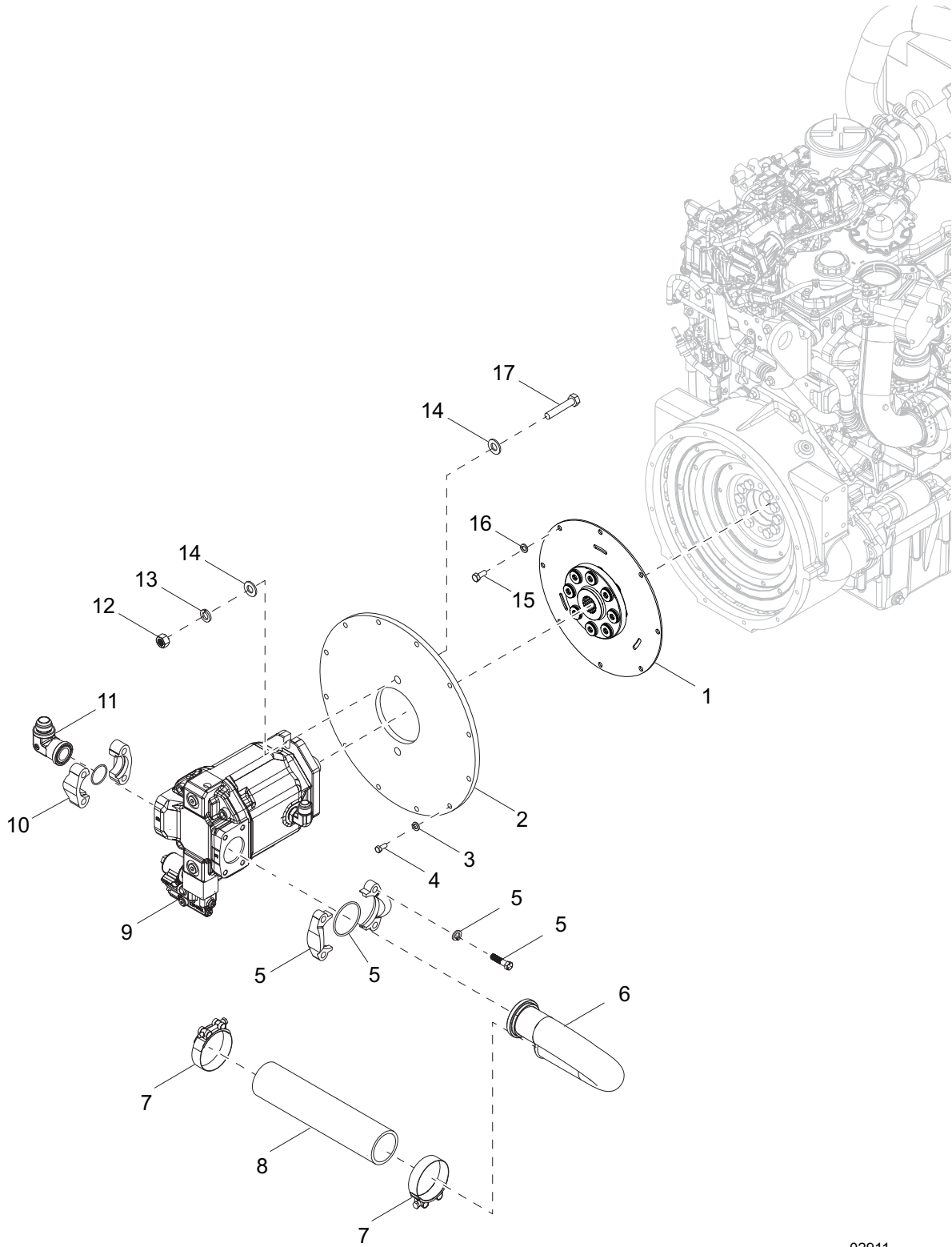

02911

PUMP ASSEMBLY

Item	Part No.	Qty	Description	Notes
1	10000040947	1	Coupling, flywheel SAE 11.50	
2	10000041006	1	Plate, pump mounting	
3	60026	12	Washer, M10 split lock	
4	38786	12	Screw, M10-1.50 x 25 hex	
5	10000046324	1	Flange assembly, 40 w/o-ring - Code 62	includes hardware
6	10000045971	1	Assembly, pump suction tube	
7	10000039878	2	Clamp, hose 2.00 OD	
8	10000039759	1	Hose, reservoir suction 2.50 OD	
9	10000045590	1	Pump, hydraulic - axial piston	
10	10000046362	1	Flange assembly, 20 w/ o-ring - Code 61	includes hardware
11	10000046347	1	Fitting, flange adapter - 37°	
12	60520	2	Nut, .625-11 hex, G8	
13	61023	2	Washer, .625 split lock	
14	60193	4	Washer .M16 flat	
15	39406	8	Screw, M8-1.25 x 16 Hex, G8.8	
16	60029	8	Washer, M8 split lock	
17	A0000138479	2	Screw, HHC .625-11 x 2.50. G5	

TANK AND LIFT STRUCTURE ASSEMBLY

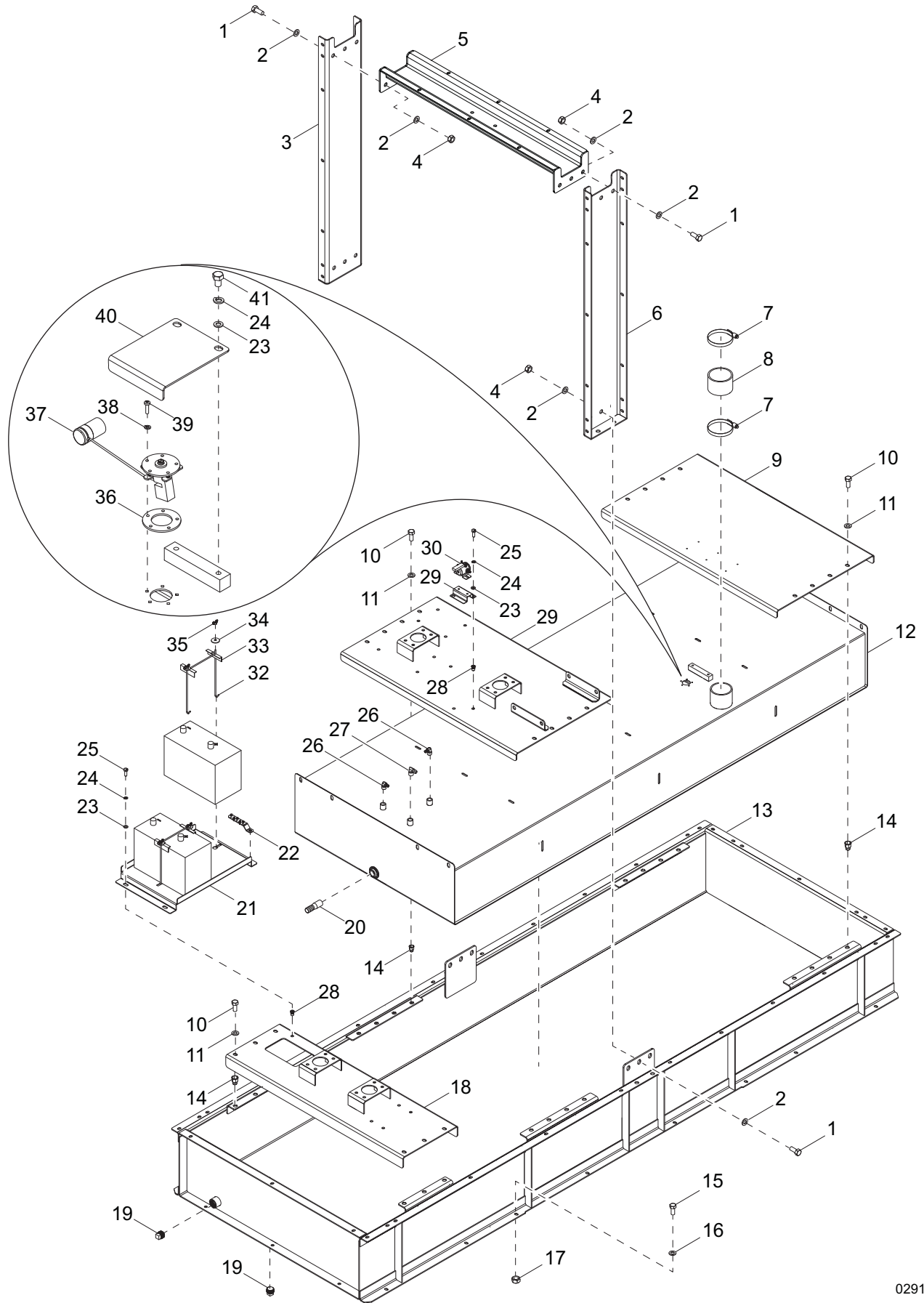

02912

TANK AND LIFT STRUCTURE ASSEMBLY

Item	Part No.	Qty	Description	Notes
1	60489	18	Screw, M16-2.00 x 40 standard hex, G10.9	
2	60193	36	Washer, M16 flat	
3	10000045083	1	Weldment, side lift post - left	
4	10000045417	18	Nut, M16-2.00 nylock, G10.9	
5	10000045703	1	Weldment, center member	
6	10000045066	1	Weldment, side lift post - right	
7	19842	2	Clamp, hose SAE072 (4.06-5.00)	
8	19612	1	Hose, air/fuel 4.00 inch	
9	10000045526	1	Support, rear storage	
10	G053607	24	Screw, M12-1.75 x 35, G8.8	
11	60012	24	Washer, M12 flat	
12	A0000149952	1	Weldment, fuel tank	
13	10000045015	1	Weldment, containment	
14	10000045480	24	Rivnut, M12-1.75	
15	G053607	22	Screw, M12-1.75 x35 HHC G8.8	
16	60012	44	Washer, M12 flat	
17	60305	22	Nut, M12-1.75 nylock, G8.8	
18	A0000167858	1	Weldment, engine support	
19	69803	2	Fitting, plug 1.00 NPT square head	
20	21451	1	Fitting, straight 1.00MNPT x 1.00 barb	
21	A0000058013	1	Bracket, battery hold down	
22	0F1465	1	Bracket, ground bar	
23	60027	8	Washer, M10 flat	
24	60026	8	Washer, M10 split lock	
25	60177	8	Screw, M10-1.50 x 30 standard hex, G10.9	
26	61159	2	Fitting, 90° .500MNPT x .375 barb - brass	
27	61223	1	Fitting, 90° .500MNPT x .500 barb - brass	
28	A0000163057	8	Rivnut, M10-1.5 x 3.8	
29	10000045526	1	Support, rear storage	
30	A0000211170	1	Assembly, solenoid relay w/diode	
31	A0000206666	1	Bracket, relay	
32	14146	2	J-bolt, .250-20 x 10.00	
33	14682	2	Bracket, battery hold down	
34	60089	2	Washer, .265 fender 1.250/.060	
35	60090	2	Nut, .250-20 wing, G5	
36	22323	1	Gasket, fuel sending unit	
37	20571	1	Sender, fuel 10-15 inch tank	
38	60252	5	Washer, #10 split lock	
39	60062	5	Screw, 10-32 x .750 pan Phillips, G2	
40	10000046470	1	Cover, fuel sender	
41	60495	2	Screw, M10-1.25 x 16 standard hex, G8.8	

TRAILER ASSEMBLY

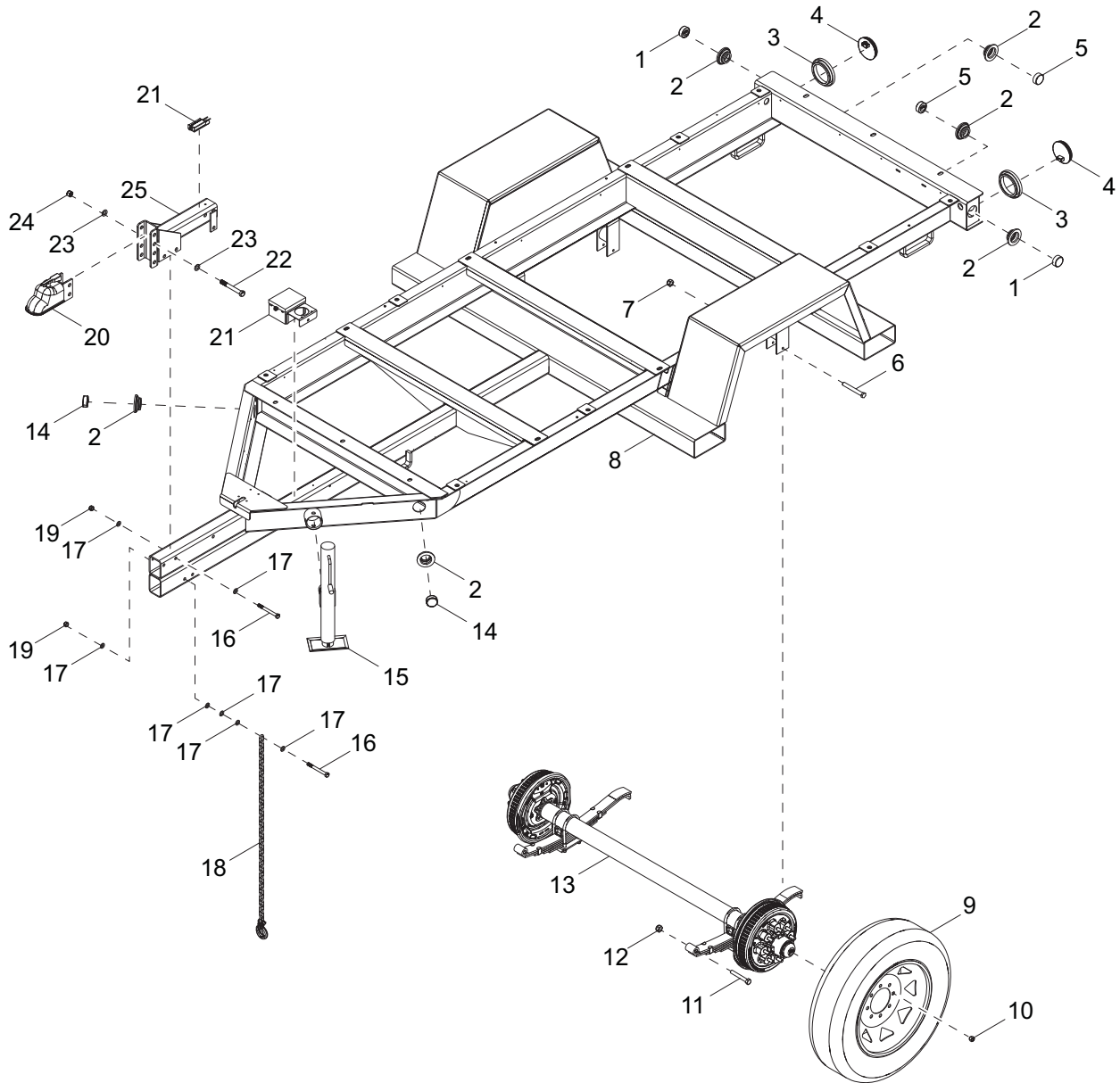

02812

TRAILER ASSEMBLY

Item	Part No.	Qty	Description	Notes
1	66703	2	Light, clearance 2.00 red - LED	
2	66394	6	Grommet, sealed beam light 2.00 - rubber	
3	10221	2	Grommet, rear light - rubber	
4	66701	2	Light, rear tail/turn 4.00 round - LED	
5	66704	2	Light, utility 2.00 clear - LED	
6	60860	2	Screw, .312-18 x 3.50 standard hex, G5	
7	A0000076799	2	Nut, .312-18 hex, G5	
8	10000045601	1	Weldment, trailer	
9	24072B	2	Wheel ST215/75R17.5 - black	
10	60096	16	Nut, .500-20 lug, G5	
11	A0000075828	4	Screw, shackle, .562-18 x 3.50 standard hex, G5	
12	60504	4	Nut, .562-18 nylock, G5	
13	10000046609	1	Axle, 8000 pound	
14	66702	2	Light, clearance 2.00 amber - LED	
15	3020800	1	Jack, square drop leg - 8000 pound	
16	0K4243	5	Screw, M12 x 120MM hex	
17	60012	20	Washer, M12 flat	
18	20159	2	Chain, safety Hi-test .375	
19	60305	5	Nut, M12 - 1.75 nylock, G8.8	
20	19519	1	Coupler, 2.31 ball	
21	19417	1	Breakaway kit	
22	10000045715	2	Screw, M16-2.00 x 130mm hex, G8.8	
23	60193	4	Washer, M16 flat	
24	10000045417	2	Nut, M16-2.00	
25	19379B	1	Weldment, hitch electric	

RECOMMENDED SPARE PARTS

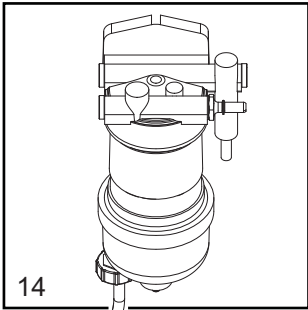
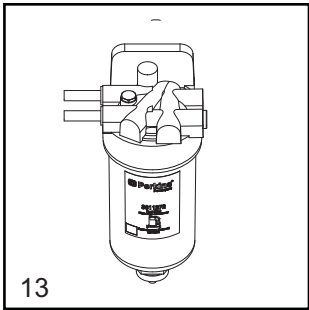
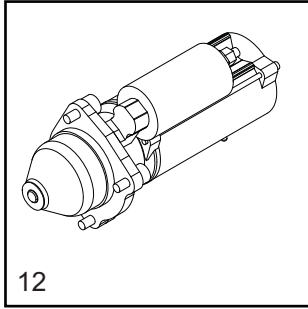
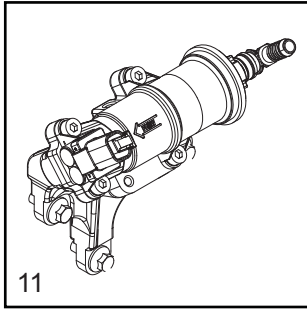
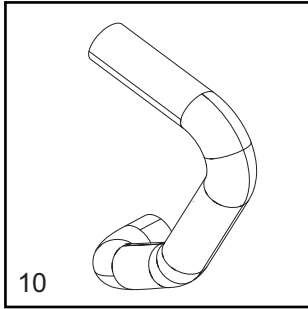
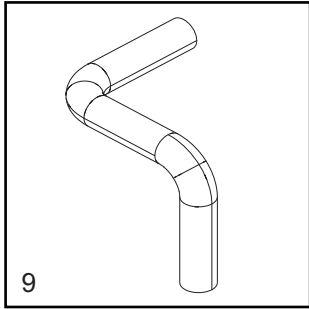
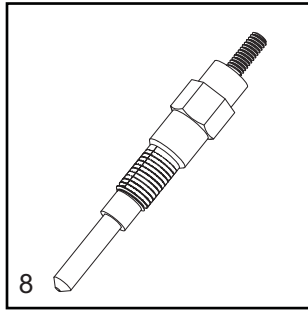
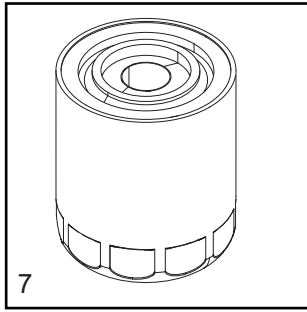
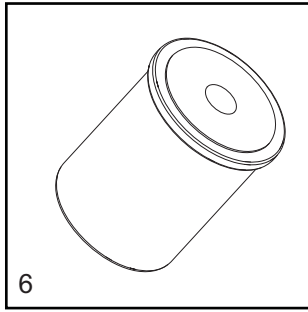
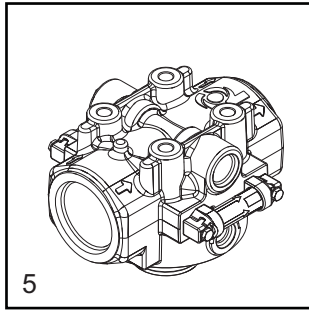
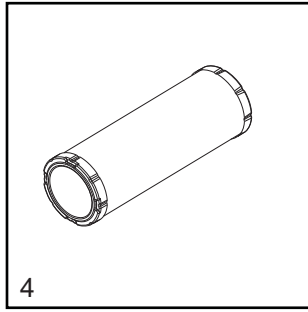
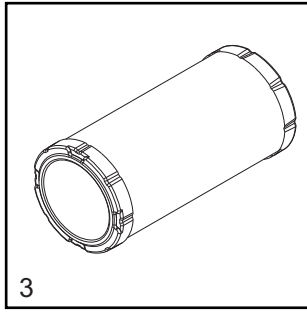
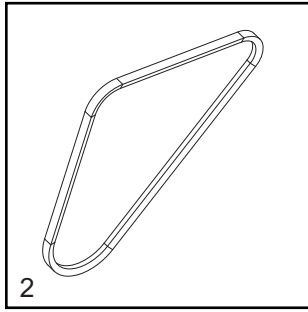
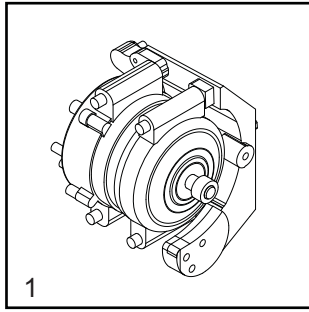

RECOMMENDED SPARE PARTS

1. Alternator	A0000338500
2. Belt, fan	A0000089814
3. Filter, air main	A0000089804
4. Filter, air safety	A0000089808
5. Head, filter	A0000373735
6. Filter, 7 micron	A0000389486
7. Filter, oil	A0000089794
8. Glow Plug	A0000338507
9. Hose, radiator - upper	A0000390719
10. Hose, radiator - lower	A0000390721
11. Pump, fuel.....	A0000336818
12. Starter	A0000338537
13. Secondary fuel filter	A0000390706
14. Primary fuel filter.....	A0000089787
15. Maintenance Kit (not shown)	A0000417656

Part No. A0000330385 Rev. A 10/09/2019

©2019 Generac Mobile Products, LLC
All rights reserved.

Specifications are subject to change without notice.
No reproduction allowed in any form without prior written consent
from Generac Mobile Products, LLC.

GENERAC | **MOBILE**

Generac Mobile Products, LLC
215 Power Drive, Berlin, WI 54923
GeneracMobileProducts.com | 800-926-9768 | 920-361-4442