

MLTS M-K

DIESEL LIGHT TOWER OWNERS MANUAL

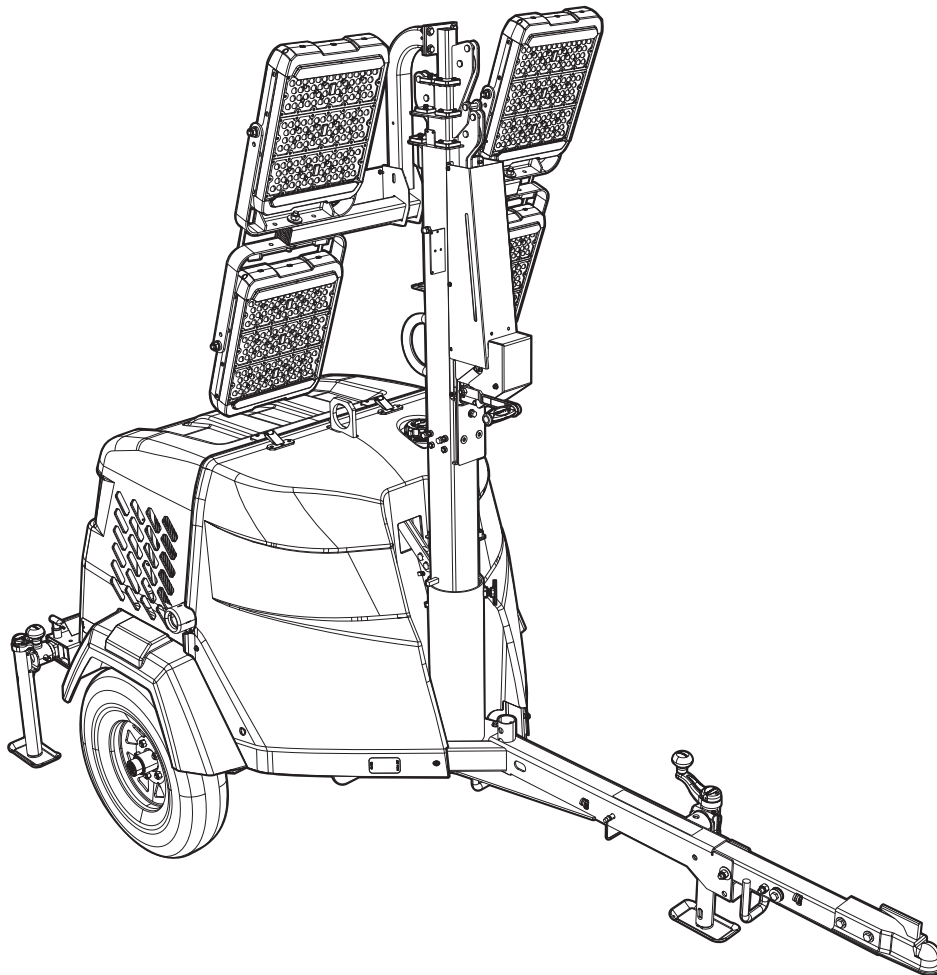

00000

For technical assistance contact:

www.generacmobileproducts.com

Technical Service

1-800-926-9768

SAVE THIS MANUAL FOR FUTURE REFERENCE

Use this page to record important information about your unit

Unit Model No.	
Unit Serial No.	
Engine Model No.	
Engine Serial No.	
Generator Model No.	
Generator Serial No.	

Record the information found on your unit data label on this page. See unit serial number location ([Unit Serial Number Locations](#)). The label plate is affixed to the inside partition, to the left of the control panel console.

Engine and generator serial numbers are located on separate data plates affixed to the engine and generator.

When contacting a Generac Mobile Authorized Service Dealer (GMASD) about parts and service, supply the complete model number and serial number of the unit.

Operation and Maintenance: Proper maintenance and care of the unit ensures a minimum number of problems and keeps operating expenses at a minimum. It is the operator's responsibility to perform all safety checks, to verify that all maintenance for safe operation is performed promptly, and to have the equipment checked periodically by a GMASD. Normal maintenance, service and replacement of parts are the responsibility of the owner or operator and, as such, are not considered defects in materials or workmanship within the terms of the warranty. Individual operating habits and usage may contribute to the need for additional maintenance or service.

WARNING

Breathing diesel engine exhaust exposes you to chemicals known to the State of California to cause cancer and birth defects or other reproductive harm.

- Always start and operate the engine in a well-ventilated area.
- If in an enclosed area, vent the exhaust to the outside.
- Do not modify or tamper with the exhaust system.
- Do not idle the engine except as necessary.

For more information go to

www.P65Warnings.ca.gov/diesel. (000394)

Table of Contents

Section 1: Introduction and Safety

Introduction	1
Read This Manual Thoroughly	1
Safety Rules	1
How to Obtain Service	1
General Hazards	2
Explosion and Fire Hazards	2
Trailer Hazards	2
Electrical Hazards	3
Battery Hazards	3
Fuel Hazards	3
Engine Safety	4
Operating Safety	4
Positioning the Unit	4
Starting the Unit	4
Raising and Lowering the Mast	4
Service Safety	5
Towing Safety	5
Hitch and Coupling	5
Running Lights	5
Wheels and Tires	5
Safe Towing Techniques	5
Tandem Towing Safety	5
Tandem Towing Safety (cont.)	6
Safety and Operating Decals	6

Section 2: General Information

Specifications	11
Unit Dimensions	12
Unit Serial Number Locations	13
Trailer Tongue Storage and Tow Positions	14
Place Trailer Tongue in Tow Position	14
Place Trailer Tongue in Storage Position	15
Component Locations	16
Control Panel	17
Standard Analog	17
Analog with Import Power (If Equipped)	17
Power Zone Autolight (If Equipped)	18
Power Zone Autolight with Import Power (If Equipped)	18
Power Zone Autolight Controller (If Equipped)	19
About UTILITY Mode (If Equipped)	21
About SLEEP Mode (If Equipped)	21

Engine Derating	21
------------------------------	----

Section 3: Operation

Unit Setup	23
Raising the Mast - Manual Winch	24
Mast Brake (If Equipped)	25
Raising the Mast - Electric Winch (If Equipped)	25
Prestart Checklist	26
Starting Unit - Analog Controls	27
Starting Unit - Power Zone Autolight Controls (Manual Mode)	28
Starting Unit - Power Zone Autolight Controls (AUTO Mode)	28
AUTO Run Scheduling	28
Operating Lights - Analog Controls	29
Operating Lights - Power Zone Autolight Controls (MANUAL Mode)	29
Operating Lights - Power Zone Autolight Controls (AUTO Mode)	30
Shutting Down Unit - Analog Controls	30
Shutting Down Unit - Power Zone Autolight Controls (MANUAL Mode)	31
Shutting Down Unit - Power Zone Controls (AUTO Mode)	31
Automatic Shutdown	32
Starting Utility Mode (If Equipped) - Power Zone Autolight Controls	32
Stopping Utility Mode (If Equipped) - Power Zone Controls	33
Dusk-to-Dawn Sensor (If Equipped)	34
Preparing Sensor for Use	34
Customer Convenience Receptacles (If Equipped)	34
Load Limit and Overload	34
Removing Loads from Receptacles (If Equipped)	34
Storing the Unit	35
Lowering the Mast - Manual Winch	35
Lowering the Mast - Electric Winch (If Equipped) ..	35
Positive Air Shutdown - PAS (If Equipped)	36
Operation	36
Maintenance	36

Table of Contents

Section 4: Operation (cont)

Coolant Heater or Engine Block Heater (If Equipped)	36
Tandem Tow (If Equipped)	37
Telemetry (If Equipped)	37
Spark Arrester (If Equipped)	37
Heated Fuel Filter (If Equipped)	37
Towing the Unit	37
Lifting the Unit	38
Tying Down the Unit	39

Section 5: Maintenance

Emissions Information	41
Daily Walk-Around Inspection	41
General Maintenance	41
Preparing for Service	41
Cleaning the Unit	41
Inspecting the Unit	41
Basic Maintenance Schedule	42
Manual Winch: Use, Operation, and Maintenance	43
Prior to Use	43
Operation	43
Maintenance	43
Electric Winch (If Equipped): Use, Operation, and Maintenance	43
Winch Mechanical Brake	43
Trailer Wheel Bearings	44
Jack Maintenance	44

Section 6: Troubleshooting

General Troubleshooting	45
Troubleshooting the Lights	46
Troubleshooting Controller Fault Indicators	47

Section 7: Wiring Diagrams

Mast Junction Box Wiring and Light Connections	49
MLTS-K Analog (No-Export Power) (1 of 3)	50
MLTS-K Analog (Export Power) (2 of 3)	51
MLTS-K Analog (Export w/Input Power) 3 of 3	52
MLTS-K Digital (No Export) 1 of 3	53
MLTS-K Digital (Export Power) 2 of 3	54

MLTS-K Digital (Export w/Input Power) 3 of 3	55
MLTS-K Analog DC Engine	56
MLTS-K Analog Control Box	57
MLTS-K Digital Control Box	58
MLTS Winch and Heated Fuel Filter (if equipped)	59
MLTS-K Positive Air Shutdown (if Equipped)	60
MLTS-M Positive Air Shutdown (If Equipped)	61
MLTS ZTR Telemetry (if equipped)	62
MLTS-K Morey Telemetry (if equipped)	63
MLTS-M/K Track Unit Telemetry (If Equipped)	64
MLTS AC Wiring (No Export Power) 1 of 3	65
MLTS-M AC Wiring (Export Power) 2 of 3	66
MLTS-M AC Wiring - Digital (240 VAC Input Power) 3 of 3	67
MLTS-M AC Wiring - Digital -120 Shore Power (If Equipped)	68
MLTS-M DC Wiring - Digital (If Equipped)	69
MLTS Trailer Lights	70

Section 8: NHTSA Trailer Requirements

Reporting Safety Defects to the United States Government	71
Tire Safety Information	71
Steps for Determining Correct Load Limit – Trailer	71
Steps for Determining Correct Load Limit – Tow Vehicle	72
Glossary of Tire Terminology	72
Tire Safety	74

Section 1: Introduction and Safety

Introduction

Thank you for purchasing a Generac Mobile product. This unit has been designed to provide high-performance, efficient operation, and years of use when maintained properly.

The information in this manual is accurate based on products produced at the time of publication. The manufacturer reserves the right to make technical updates, corrections, and product revisions at any time without notice.

Read This Manual Thoroughly



Consult Manual. Read and understand manual completely before using product. Failure to completely understand manual and product could result in death or serious injury. (000100a)

If any section of the manual is not understood, contact your nearest GMASD, or contact Generac Mobile at 1-800-926-9768 or www.generacmobileproducts.com with any questions or concerns.

The owner is responsible for proper maintenance and safe use of the equipment. Comply with regulations the Occupational Safety and Health Administration (OSHA) has established, or with equivalent standards. Also, verify that the unit is applied, used, and maintained in accordance with the manufacturer's instructions and recommendations. Do nothing that might alter safe application/usage and render the unit in noncompliance with the aforementioned codes, standards, laws, and regulations.

Save these instructions for future reference. This manual contains important instructions for the unit that should be followed during setup, operation and maintenance of the unit and battery. ALWAYS supply this manual to any individual that will use this machine.

Safety Rules

The manufacturer cannot anticipate every possible circumstance that might involve a hazard. The alerts in this manual, and on tags and decals affixed to the unit, are not all inclusive. If using a procedure, work method, or operating technique that the manufacturer does not specifically recommend, verify that it is safe for others and does not render the equipment unsafe.

Throughout this publication, and on tags and decals affixed to the unit, DANGER, WARNING, CAUTION, and NOTE blocks are used to alert personnel to special instructions about a particular operation that may be hazardous if performed incorrectly or carelessly. Observe them carefully. Alert definitions are as follows:



Indicates a hazardous situation which, if not avoided, will result in death or serious injury.

(000001)



Indicates a hazardous situation which, if not avoided, could result in death or serious injury.

(000002)



Indicates a hazardous situation which, if not avoided, could result in minor or moderate injury.

(000003)

NOTE: Notes contain additional information important to a procedure and will be found within the regular text of this manual.

These safety alerts cannot eliminate the hazards that they indicate. Common sense and strict compliance with the special instructions while performing the action or service are essential to preventing accidents.

How to Obtain Service

When the unit requires servicing or repairs, contact a GMASD for assistance. Service technicians are factory-trained and are capable of handling all service needs. For assistance locating a dealer, go to <https://www.generac-mobileproducts.com/parts-service/find-service>.

When contacting a GMASD about parts and service, always supply the complete model and serial number of the unit as given on the data decal located on the unit. Record the model and serial numbers in the spaces provided on the front cover of this manual.

General Hazards



⚠ DANGER

Asphyxiation. Running engines produce carbon monoxide, a colorless, odorless, poisonous gas. Carbon monoxide, if not avoided, will result in death or serious injury. (000103)



⚠ WARNING

Hearing Loss. Hearing protection is recommended when using this machine. Failure to wear hearing protection could result in permanent hearing loss. (000107)



⚠ WARNING

Moving Parts. Keep clothing, hair, and appendages away from moving parts. Failure to do so could result in death or serious injury. (000111)



⚠ WARNING

Hot Surfaces. When operating machine, do not touch hot surfaces. Keep machine away from combustibles during use. Hot surfaces could result in severe burns or fire. (000108)

⚠ WARNING

Risk of injury. Do not operate or service this machine if not fully alert. Fatigue can impair the ability to operate or service this equipment and could result in death or serious injury. (000215a)



⚠ WARNING

Risk of burns. Allow engine to cool before draining oil or coolant. Failure to do so could result in death or serious injury. (000139)

Explosion and Fire Hazards



⚠ DANGER

Explosion and Fire. Fuel and vapors are extremely flammable and explosive. Add fuel in a well ventilated area. Keep fire and spark away. Failure to do so will result in death or serious injury. (000105)



⚠ WARNING

Risk of Fire. Unit must be positioned in a manner that prevents combustible material accumulation underneath. Failure to do so could result in death or serious injury. (000147)



⚠ WARNING

Risk of Fire. Hot surfaces could ignite combustibles, resulting in fire. Fire could result in death or serious injury. (000110)

Trailer Hazards

⚠ WARNING

Personal injury. Trailer must be securely coupled to the hitch with the chains correctly attached. Uncoupled or unchained towing could result in death or serious injury. (000233a)

⚠ WARNING

Personal injury. Do not operate unit during transport. Doing so could result in death, serious injury, or property damage. (000231a)

⚠ WARNING

Crushing hazard. Verify unit is properly secured and on level ground. An unsecured unit can suddenly roll or move, causing death or serious injury. (000234a)

⚠ WARNING

Property or Equipment Damage. Tighten wheel lug nuts after first 50 miles to factory specifications. Failure to do so could result in death, serious injury, property or equipment damage. (000235)

Electrical Hazards



⚠ DANGER

Electrocution. In the event of electrical accident, immediately shut power OFF. Use non-conductive implements to free victim from live conductor. Apply first aid and get medical help. Failure to do so will result in death or serious injury. (000145)



⚠ DANGER

Electrocution. Water contact with a power source, if not avoided, will result in death or serious injury. (000104)



⚠ DANGER

Electrocution. Contact with bare wires, terminals, and connections while generator is running will result in death or serious injury. (000144)



⚠ DANGER

Electrocution. Verify electrical system is properly grounded before applying power. Failure to do so will result in death or serious injury. (000152)



⚠ DANGER

Electrocution. Do not wear jewelry while working on this equipment. Doing so will result in death or serious injury. (000188)



⚠ DANGER

Electrocution. DO NOT use the unit if electrical cord is cut or worn through. Doing so will result in death or serious injury. (000263a)

Battery Hazards



⚠ DANGER

Electrocution. Do not wear jewelry while working on this equipment. Doing so will result in death or serious injury. (000188)



⚠ WARNING

Explosion. Batteries emit explosive gases while charging. Keep fire and spark away. Wear protective gear when working with batteries. Failure to do so could result in death or serious injury. (000137a)



⚠ WARNING

Explosion. Do not dispose of batteries in a fire. Batteries are explosive. Electrolyte solution can cause burns and blindness. If electrolyte contacts skin or eyes, flush with water and seek immediate medical attention. (000162)



⚠ WARNING

Risk of burn. Do not open or mutilate batteries. Batteries contain electrolyte solution which can cause burns and blindness. If electrolyte contacts skin or eyes, flush with water and seek immediate medical attention. (000163a)

Always recycle batteries in accordance with local laws and regulations. Contact your local solid waste collection site or recycling facility to obtain information on local recycling processes. For more information on battery recycling, visit the Battery Council International website at: <http://batteryCouncil.org>.

Fuel Hazards



⚠ DANGER

Explosion and fire. Fuel and vapors are extremely flammable and explosive. No leakage of fuel is permitted. Keep fire and spark away. Failure to do so will result in death or serious injury. (000192)



⚠ DANGER

Risk of fire. Allow fuel spills to completely dry before starting engine. Failure to do so will result in death or serious injury. (000174)

- **DO NOT** fill fuel tank near an open flame, while smoking, or while engine is running. **DO NOT** fill tank in an enclosed area with poor ventilation.

- **DO NOT** operate with the fuel tank cap loose or missing.

Engine Safety

Internal combustion engines present special hazards during operation and fueling. Failure to follow the safety guidelines described below could result in severe injury or death. Read and follow all safety alerts described in the engine operator's manual. A copy of this manual was supplied with the unit when it was shipped from the factory.

- **DO NOT** run engine indoors or in an area with poor ventilation. Make sure engine exhaust cannot seep into closed rooms or ventilation equipment.
- **DO NOT** clean air filter with gasoline or other types of low flash point solvents.
- **DO NOT** operate the unit without a functional exhaust system.
- Shut the engine down if any of the following conditions exist during operation:
 - Noticeable change in engine speed.
 - Loss of electrical output.
 - Equipment connected to the unit overheats.
 - Sparking occurs.
 - Engine misfires or there is excessive engine/generator vibration.
 - Protective covers are loose or missing.
 - Ambient air temperature is above 120 °F (49 °C).

Operating Safety

Positioning the Unit



⚠ DANGER

High Voltage. Verify area above unit is clear of overhead wires and obstructions. Contact with high-voltage power lines will result in death or serious injury. (000260a)



⚠ WARNING

Burn hazard. Never operate lights with a damaged or missing lens cover. Lamps are hot and pressurized while in use. Unprotected lamps can shatter, causing severe injury. (000277)

- The area immediately surrounding the unit should be dry, clean, and free of debris.
- Position and operate the unit on a firm, level surface.
- If the unit is equipped with a frame grounding stud, follow any local, state, and National Electrical Code (NEC) guidelines when connecting.

Starting the Unit



⚠ DANGER

Electrocution. DO NOT use the unit if electrical cord is cut or worn through. Doing so will result in death or serious injury. (000263a)



⚠ WARNING

Equipment damage. Do not attempt to start or operate a unit in need of repair or scheduled maintenance. Doing so could result in serious injury, death, or equipment failure or damage. (000291)

Raising and Lowering the Mast



⚠ WARNING

Electrocution. Do not set up or operate this unit if severe weather is expected. Lightning strikes can kill or cause severe injury even if you are not touching the unit. (000296)



⚠ WARNING

> 65 mph Do not set up the unit if high winds are expected. High winds can cause the unit to tip or fall, causing severe injury or machine damage. (000297)



⚠ WARNING

Personal injury or equipment damage. Do not raise or lower the mast while the unit is operating. Doing so can break the lenses and cause the lamps to shatter. (000279)



⚠ WARNING

Personal Injury. Stop immediately if the mast hangs up or the winch cable develops slack. Excess slack could cause the mast to collapse, resulting in personal injury or equipment damage. (000265)



⚠ WARNING

Tipping hazard. Extend the outriggers and level the unit before raising the mast. Keep the outriggers extended while the mast is up. Failure to do so could cause the unit to tip and fall and could result in death or serious injury. (000266)

- Keep area around the unit clear of people while raising and lowering the mast.
- **ALWAYS** lower the mast when not in use.

- The tower extends up to 23 ft (7 m). Verify area above trailer is open and clear of overhead wires and obstructions.
- If for any reason any part of the mast hangs up or winch cable develops slack while raising or lowering tower, stop immediately and contact a GMASD.
- **NEVER** remove safety pin or pull mast locking pin while tower is up.

Service Safety



Accidental start-up. Disconnect negative battery terminal before servicing to prevent accidental engine rotation. Failure to do so could result in death or serious injury. (000148a)

This unit uses high voltage circuits capable of causing serious injury or death. Only a qualified and licensed electrician should troubleshoot or repair problems occurring in this equipment.

- Before servicing the unit, verify the control power switch and circuit breakers are OFF (O), and the negative (-) terminal on the battery is disconnected. **DO NOT** perform even routine service (oil/filter changes, cleaning, etc.) unless all electrical components are shut down.
- **ALWAYS** use extreme caution when servicing this unit in damp conditions. Do not service the unit if skin or clothing is wet. Do not allow water to collect around the base of the unit.
- **DO NOT** wash the unit with high pressure hoses, power washers, or steam cleaners. Water may collect in the unit, causing damage to electrical parts.
- Replace all missing and hard to read decals. Decals provide important operating instructions and warn of dangers and hazards.
- Wear heavy leather gloves when handling winch cables. Never let cables slip through bare hands.
- Only use mild soap and water to clean the lens covers. Other chemicals may damage the lens covers.

Towing Safety

Towing a trailer requires care. Both the trailer and vehicle must be in good condition and securely fastened to each other to reduce the possibility of an accident. Some states require that large trailers be registered and licensed. Contact your local Department of Transportation office to check on license requirements for your particular unit.

Hitch and Coupling

- Verify the hitch and coupling on the towing vehicle are rated equal to, or greater than, the trailer's gross vehicle weight rating (GVWR).
- Verify the trailer hitch and the coupling are compatible. Verify the coupling is securely fastened to the vehicle.
- **DO NOT** tow trailer using defective parts. Inspect the hitch and coupling for wear or damage.
- Connect safety chains in a crossing pattern under the tongue.
- Before towing the trailer, verify that the weight of the trailer is equal across all tires. On trailers with adjustable height hitches, adjust the angle of the trailer tongue to keep the trailer as level as possible.

Running Lights

Verify directional and brake lights on the trailer are connected and working properly.

Wheels and Tires

- Inspect trailer tires for wear and proper inflation.
- Verify wheel lug nuts are present and tightened to the specified torque.

Safe Towing Techniques

- Practice turning, stopping, and backing up in an area away from heavy traffic prior to transporting the unit.
- Maximum recommended speed for highway towing is 65 mph (105 km/h). Recommended off-road towing speed is 10 mph (16 km/h) or less, depending on terrain.
- When towing, maintain extra space between vehicles and avoid soft shoulders, curbs, and sudden lane changes.

Tandem Towing Safety

This unit may be equipped with a tandem tow hitch. This feature allows the operator to tow a second light tower behind the unit.

- Do not use the tandem tow hitch to tow any other equipment other than a unit of the same model.
- Local regulations may limit or prohibit tandem towing. There may be restrictions on towing speed, overall vehicle length, the types of roads on which the units can be towed, and which road lanes are permissible for towing vehicles. Check with the local authority having jurisdiction (for example, the state Department of Transportation) before using the tandem tow hitch.

Tandem Towing Safety (cont.)

- Connect the second unit using the same procedures and preventative safety measures as required for a single unit. Safety and Operating Decal

Safety and Operating Decals

See [Figure 1-1](#) through [Figure 1-3](#). This unit features numerous safety and operating decals. These decals provide important operating instructions and warn of dangers and hazards. The following diagrams illustrate decal locations and descriptions.

Replace any missing or hard-to-read decals and use care when washing or cleaning the unit. Decal part numbers can be found in the parts manual at www.generacmobileproducts.com.

ID	Description	ID	Description
1	Setup and Take-Down Instructions (Electric)	17	Control Panel Label (not shown)
2	Setup and Take-Down Instructions (Manual)	18	Neutral Bonded to Frame
3	Danger—Overhead Power Lines	19	Not A Step
4	Warning—Electrical Storms and High Wind	20	Warning—High Temperature: Do Not Remove Guard
5	Owner's Manual Location	21	Mast Junction Box Wiring (inside)
6	Electric Shock Hazard	22	Warning—Do Not Retract Outriggers With Tower Up
7	Warning—Hot Surface	23	Stowed Position
8	Warning—Pressurized Liquid	24	Lifting Point
9	Warning—Entanglement Hazard	25	Forklift and Tie-Down Point
10	Warning—Cutting Hazard	26	Engine Operation
11	Disconnect Battery Before Servicing	27	Danger—Fuel and Fueling Hazards
12	FCC Label (MLTS-K Only)	28	Ultra Low Sulfur Diesel Fuel Only
13	Danger—Carbon Monoxide	29	Tie-Down Point
14	Electrical Ground Connection	30	Towing Instructions
15	Notice—Winch Operation	31	Ambient Operating Temperature
16	Warning—Diesel Exhaust		

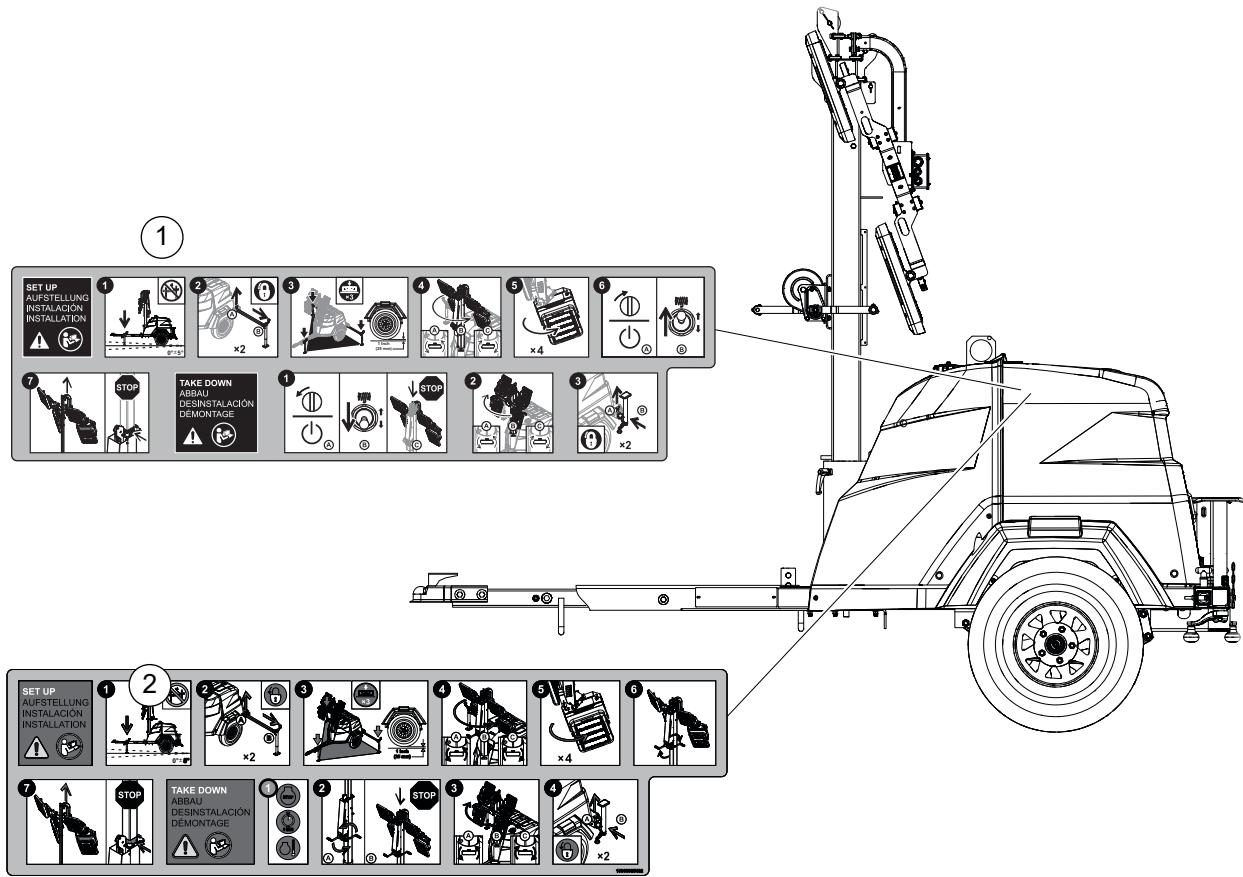

008626

Figure 1-1. Decal Locations (1 of 3)

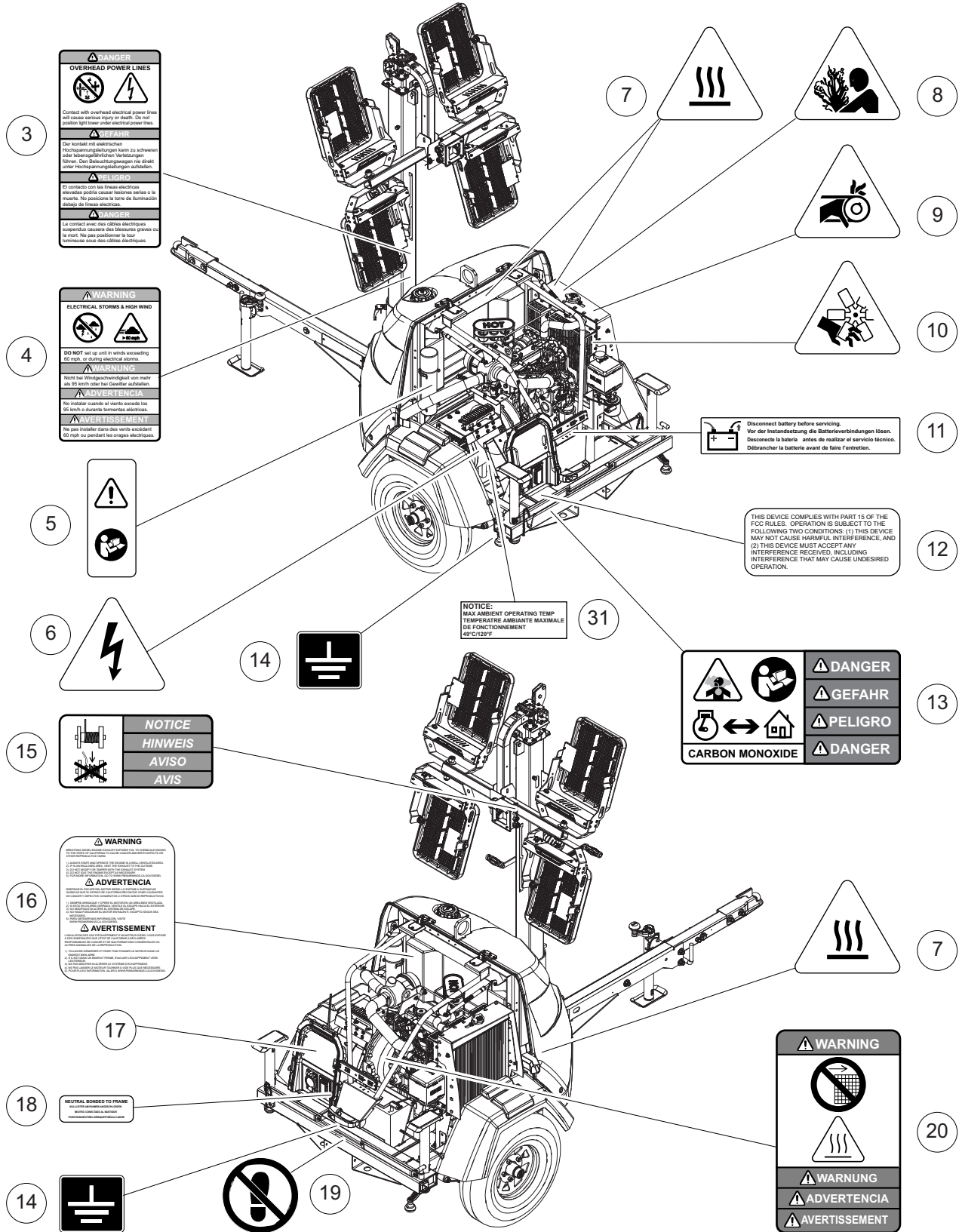

015185

Figure 1-2. Decal Locations (2 of 3)

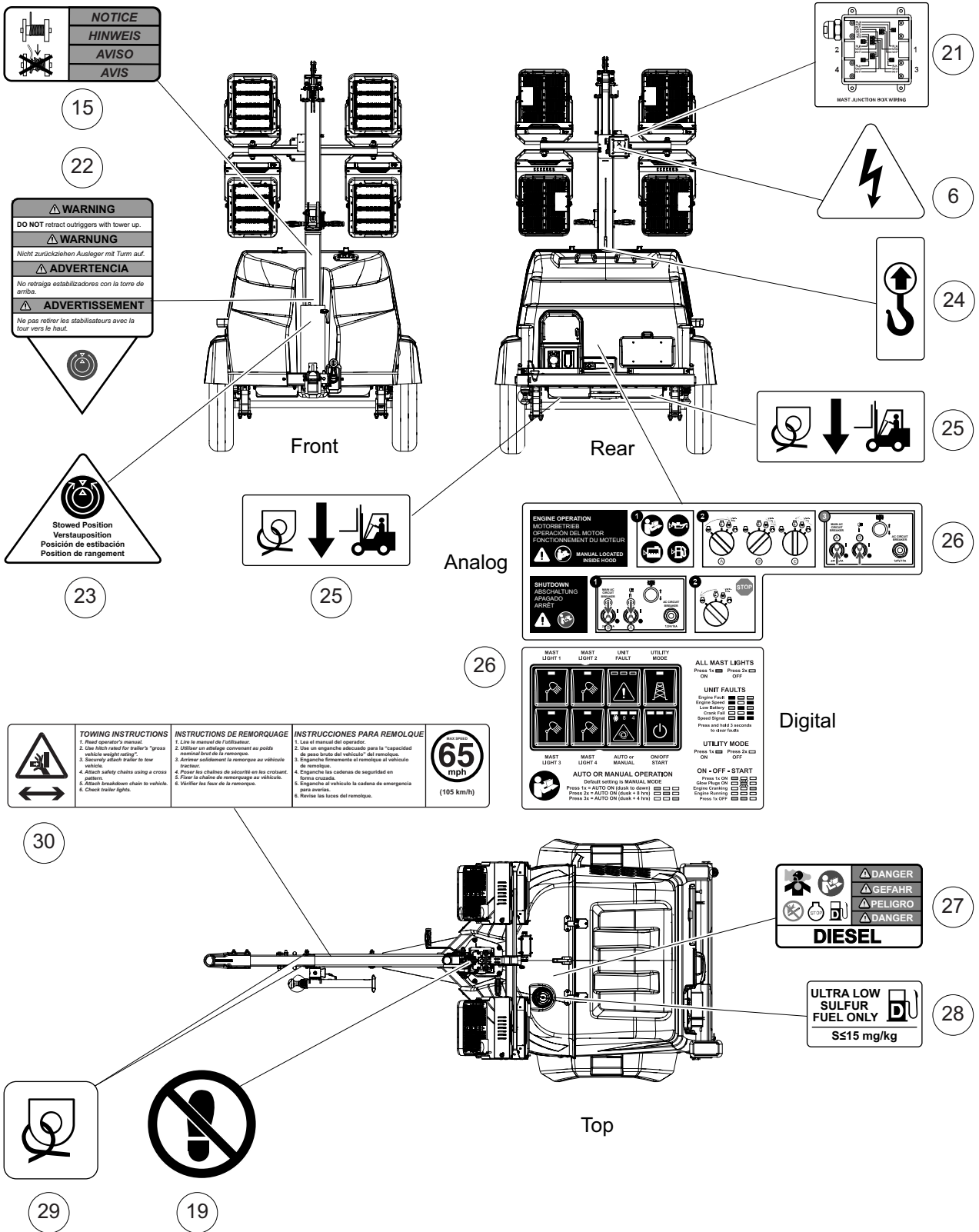

Figure 1-3. Decal Locations (3 of 3)

THIS PAGE INTENTIONALLY LEFT BLANK

Section 2: General Information

Specifications

Description	Unit of Measure	No Export Power Mitsubishi	Export Power Mitsubishi	No Export Power Kubota	Export Power Kubota
Engine					
Make (Model)	—	Mitsubishi® (L2E)	Mitsubishi® (L2E)	Kubota® (Z482)	Kubota® (Z482)
EPA Certification	Tier	4 Final	4 Final	4 Final	4 Final
Fuel Consumption—Lights Only	gph (Lph)	0.25 (0.95)	0.24 (0.91)	0.19 (0.72)	0.19 (0.72)
Battery—Group Number	—	24	24	24	24
Battery—Voltage (Qty. Per Unit)	VDC (qty)	12 (1)	12 (1)	12 (1)	12 (1)
Battery—Rating	CCA	440	440	440	440
Capacities					
Fuel Tank Volume	gal (L)	42 (159)	42 (159)	42 (159)	42 (159)
Usable Fuel Volume	gal (L)	39.9 (151)	39.9 (151)	39.9 (151)	39.9 (151)
Coolant (Incl. Engine)	qt (L)	4.1 (3.9)	4.1 (3.9)	4.0 (3.8)	4.0 (3.8)
Oil (Incl. Filter)	qt (L)	3.5 (3.4)	3.5 (3.4)	4.0 (3.8)	4.0 (3.8)
Maximum Run Time (Lights Only)	hr	162	165	206	206
Generator/Alternator					
Make (Model)	—	Marathon Electric® (201CSA5430)	Marathon Electric® (201CSA5411)	Marathon Electric® (201CSA5430)	Marathon Electric® (201CSA5423)
Power Output	kW (kVA)	1.4 (1.4)	2.4 (2.4)	1.4 (1.4)	2.6 (2.6)
Output Voltage	V	120 (1Ø)	120 (1Ø)	150 (1Ø)	120/240 (1Ø)
Output Amperes	A	11.6	20	9.4	10.8
Frequency	Hz	60	60	60	60
AC Distribution					
Circuit Breaker Size	A	15	20	15	15
Lighting					
Lighting Type	—	Light-emitting diode (LED)	Light-emitting diode (LED)	Light-emitting diode (LED)	Light-emitting diode (LED)
Brightness	lm	198,400	198,400	198,400	198,400
Trailer					
Hitch—Standard	size, type	2 in (51 mm) ball	2 in (51 mm) ball	2 in (51 mm) ball	2 in (51 mm) ball
Maximum Tire Pressure	psi (kPA)	50 (345)	50 (345)	50 (345)	50 (345)
Weight					
Dry	lb (kg)	1,110 (503.5)	1,185 (537.5)	1,114 (501)	1,170 (531)
Operating	lb (kg)	1,415 (641.8)	1,440 (653.2)	1,389 (630)	1,445 (655)

Specifications are subject to change without notice.

Unit Dimensions

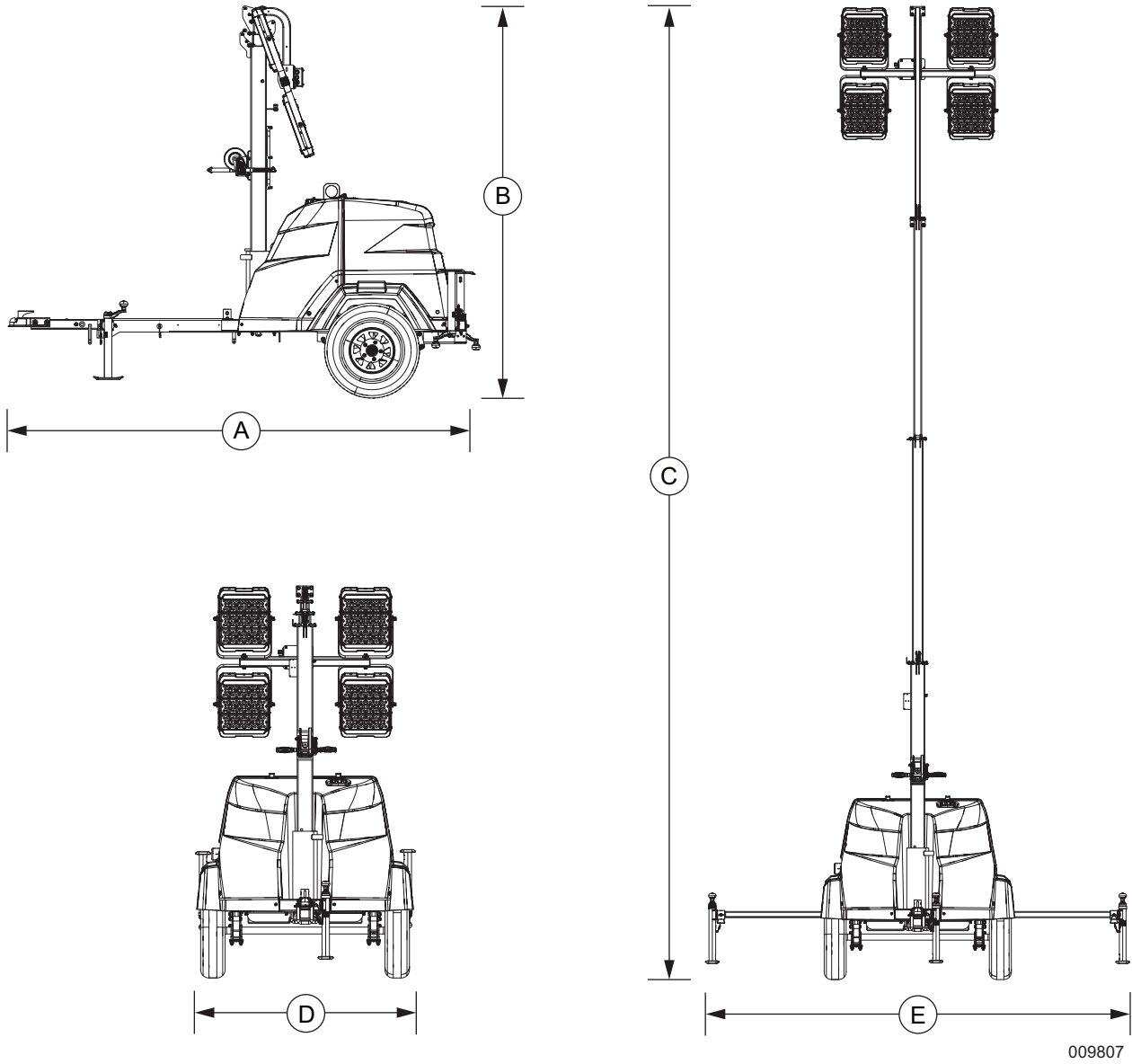

009807

Figure 2-1. Unit Dimensions

A	B	C	D	E
118 in (3 m)	101 in (2.6 m)	23 ft (7 m)	57 in (1.45 m)	10 ft (3.05 m)

Unit Serial Number Locations

Refer to the illustration to locate the unit ID tag and Vehicle Identification Number (VIN) tag on the unit. Important information, such as the unit serial number, model number, VIN, and tire loading information are

found on these tags. Record the information from these tags so it is available if the tags are lost or damaged. When ordering parts or requesting assistance, you may be asked to provide this information.

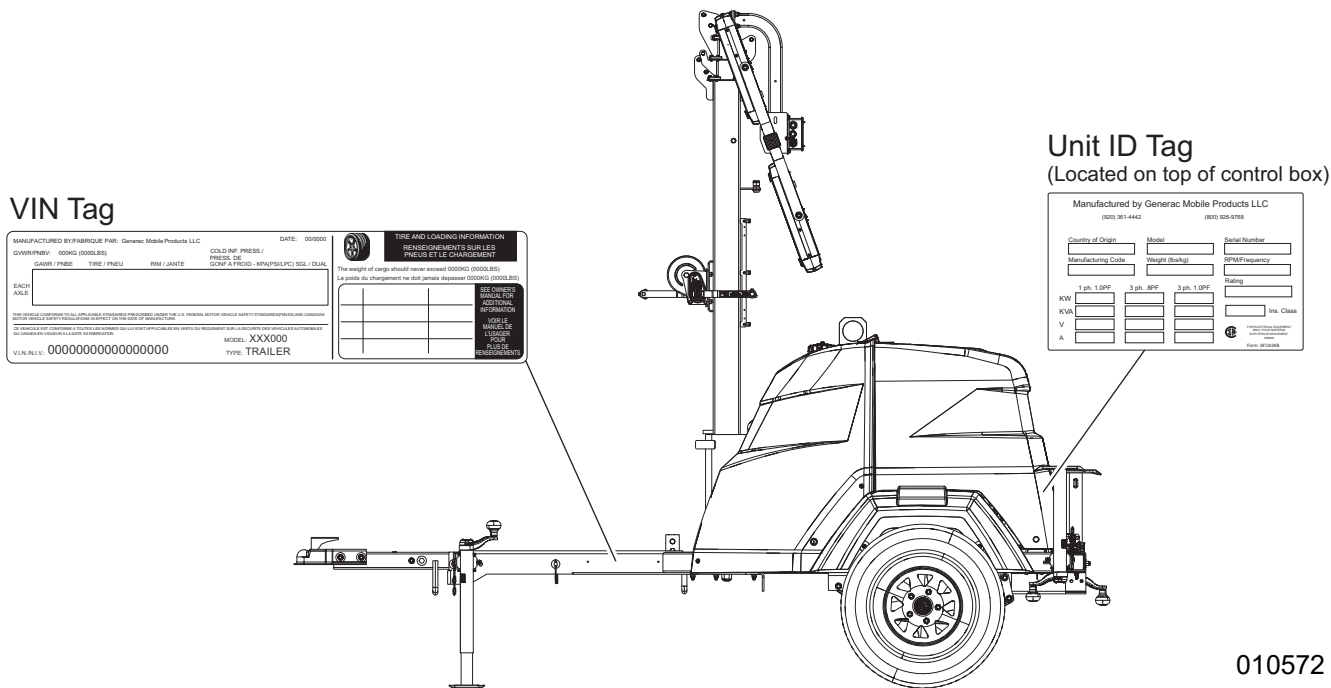

Figure 2-2. Serial Number Locations

010572

Trailer Tongue Storage and Tow Positions

The trailer tongue is designed to fold upright for shipping and storage.

IMPORTANT NOTE: Do not attempt to tow the unit with trailer tongue in the storage position.

Place Trailer Tongue in Tow Position

1. Verify unit is on a level surface and wheels are blocked.

NOTE: See [Figure 2-3](#). Unit ships from factory with jack in the storage location (A).

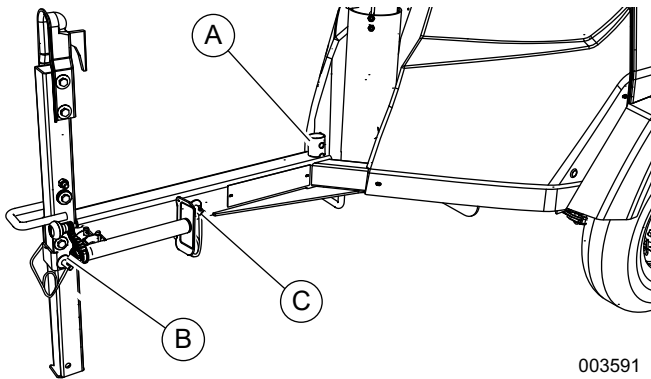

Figure 2-3. Jack and Pin Locations

2. Remove clevis securing jack parallel to ground.
3. Remove jack from tongue weldment. Hold jack vertically and extend until weldment on jack is aligned with tongue weldment.
4. See [Figure 2-4](#). Install jack and secure with clevis (D).

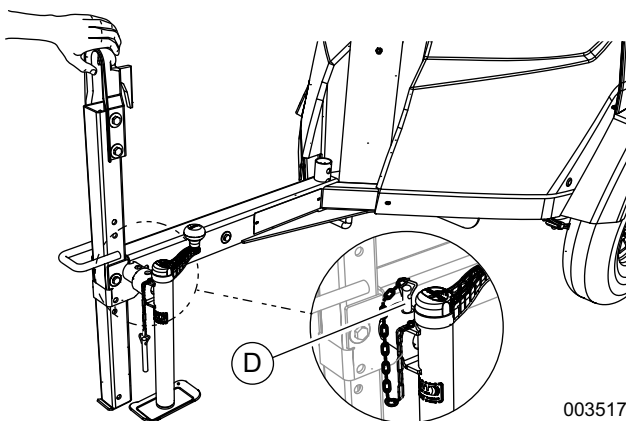

Figure 2-4. Jack Installed

5. See [Figure 2-3](#). Remove pins (B) and (C).



CAUTION

Pinching and crushing hazard. To avoid possible injury, keep fingers away from pivot point when folding or unfolding trailer tongue.

(000313)

6. See [Figure 2-5](#). Using both hands, slowly lower trailer tongue into tow position.

NOTE: Varying levels of effort may be required depending on terrain.

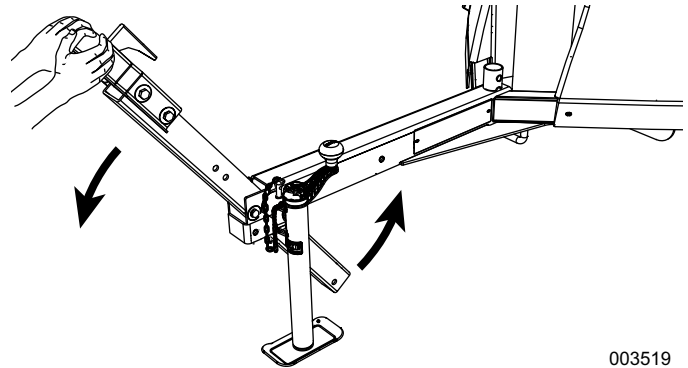

003519

Figure 2-5. Lower Trailer Tongue into Tow Position

7. See [Figure 2-6](#). Install pins as shown to secure trailer tongue in tow position.

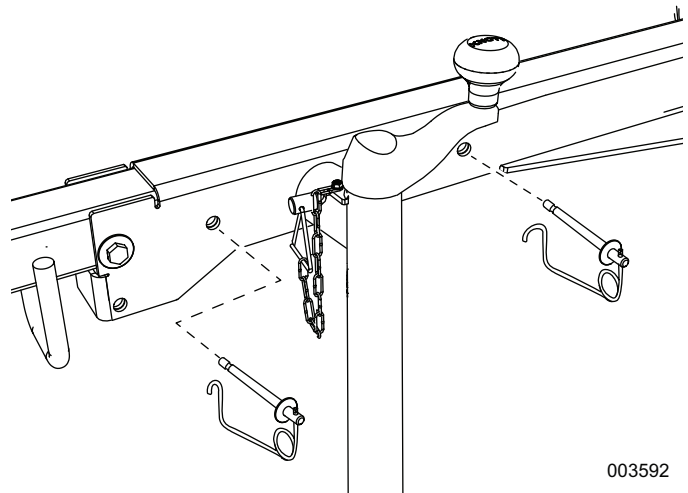

003592

Figure 2-6. Install and Secure Pins

Place Trailer Tongue in Storage Position

1. Verify unit is on a level surface and wheels are blocked.
2. See [Figure 2-7](#). Extend jack (A) enough to allow minimum effort to pivot trailer tongue into storage position.

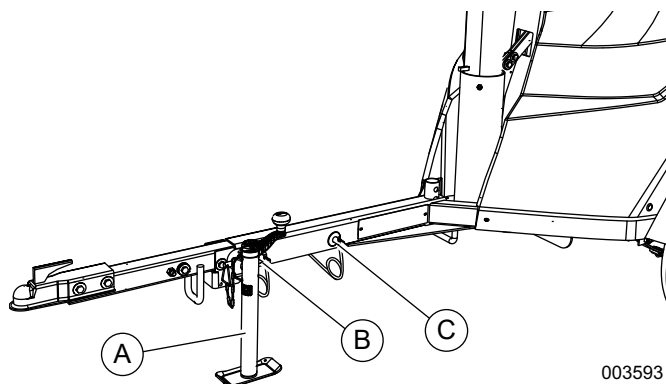

Figure 2-7. Extend Jack and Remove Pins

3. Remove pins (B) and (C) from trailer tongue.



CAUTION

Pinching and crushing hazard. To avoid possible injury, keep fingers away from pivot point when folding or unfolding trailer tongue.

(000313)

4. See [Figure 2-8](#). Pivot trailer tongue into storage position.

NOTE: Varying levels of effort may be required depending on terrain.

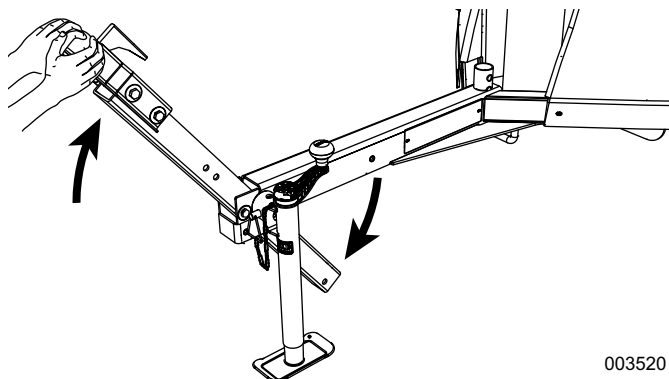
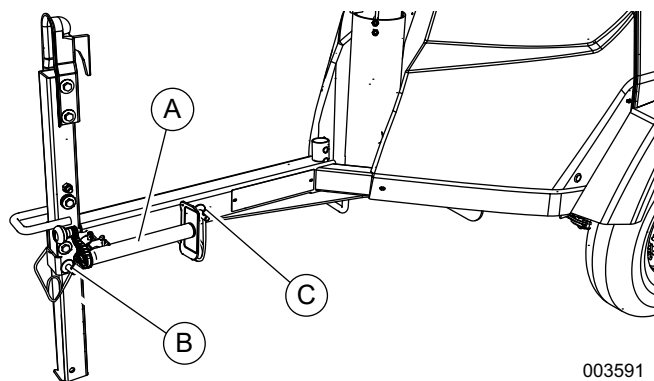

Figure 2-8. Pivot Trailer Tongue Into Storage Position

5. See [Figure 2-9](#). Install pins (B) and (C) at locations shown to secure trailer tongue in storage position.



003591

Figure 2-9. Install Pins and Rotate Jack

6. Remove clevis and remove jack (A) from tongue weldment.
7. Completely retract jack.
8. Rotate jack 90° counterclockwise, place jack on tongue weldment, and install clevis to secure jack parallel to ground.

Component Locations

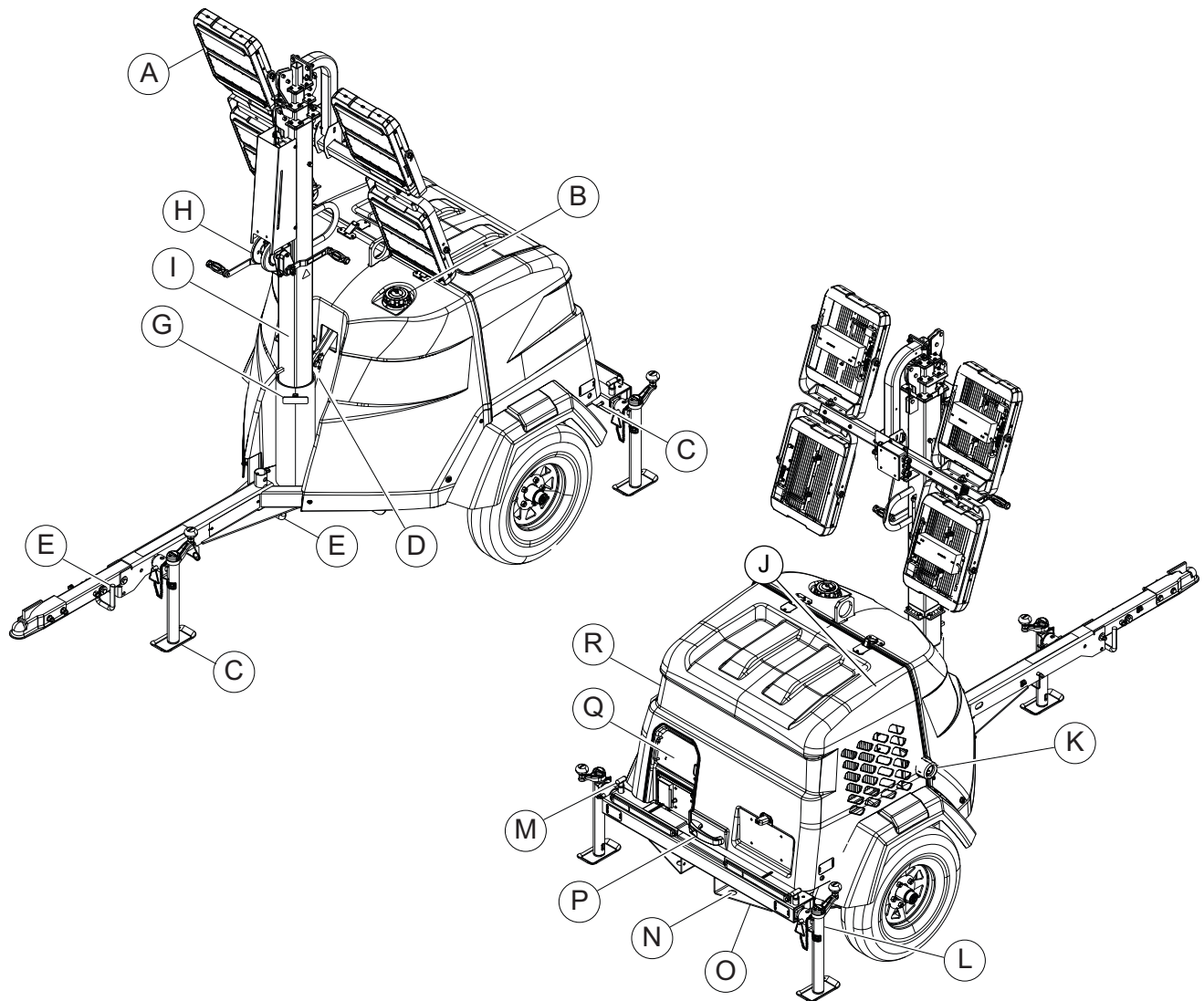

010573

Figure 2-10. Exterior Components

- | | |
|--|--|
| A Light fixture (4 locations) | J Unit lift point |
| B Fuel fill port | K Exhaust |
| C Grounding stud | L Outrigger jack (2 locations) |
| D Dawn-to-dusk sensor (behind mast) | M Outrigger pin (2 locations) |
| E Tie-down point | N Rear tie-down point (2 locations) |
| F Tongue jack | O Fork pocket (2 locations) |
| G Mast rotation knob | P Hood latch |
| H Winch | Q Control panel access door |
| I Mast | R Hood |

Control Panel

Standard Analog

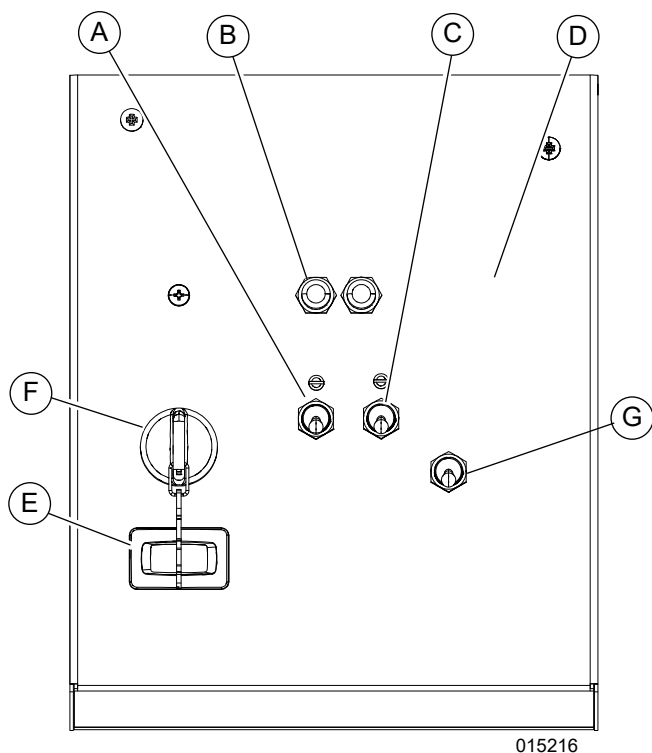

Figure 2-11. Standard Analog Controls

- A** Main circuit breaker
- B** DC circuit breaker (2 locations)
- C** Light fixtures ON-OFF switch
One switch controls power to all light fixtures
- D** AC circuit breaker
Controls export power (if equipped)
- E** Engine hour meter
Displays how many hours engine has run
- F** Engine ignition switch
- G** Mast UP-DOWN switch (if equipped)

Analog with Import Power (If Equipped)

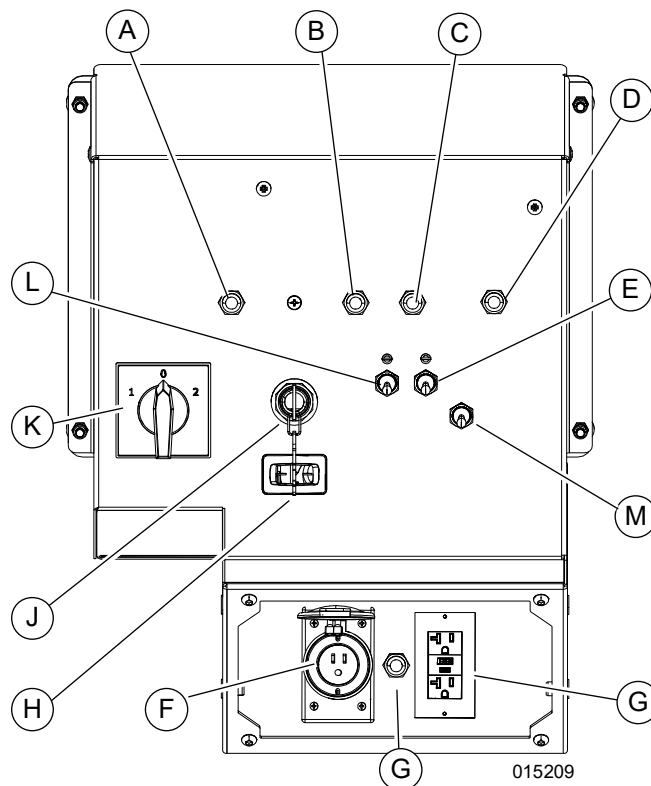

Figure 2-12. Analog Controls With Optional Import Power

- A** GFCI breaker (if equipped)
- B** DC circuit breaker
- C** DC circuit breaker
- D** AC circuit breaker (if equipped)
- E** Light switch
- F** Inlet receptacle (5-15P)
- G** Outlet receptacle (5-20R GFC)
- H** Engine hour meter
Displays how many hours engine has run
- J** Engine ignition switch
- K** Engine/utility power selector switch (flex switch)
- L** Main breaker
- M** Mast UP-DOWN switch (if equipped)
- P** Circuit breaker (if equipped)

Power Zone Autolight (If Equipped)

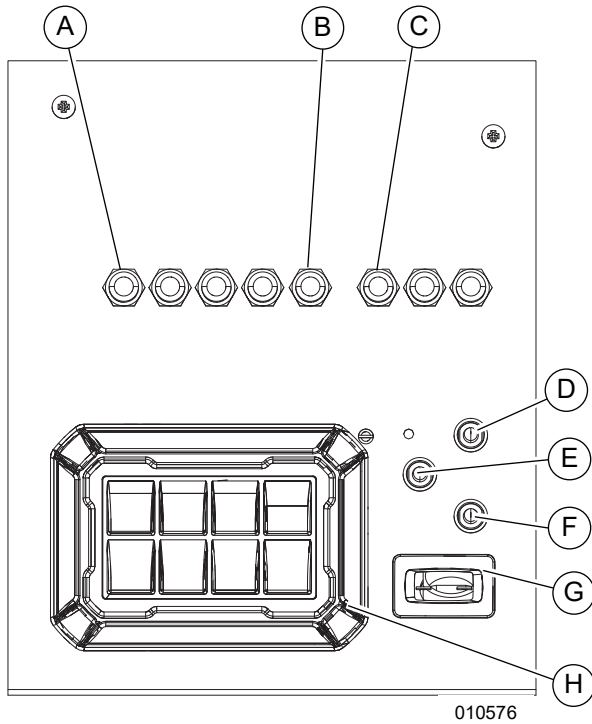

Figure 2-13. Optional Power Zone Autolight Controls

- A** AC circuit breaker—light fixture (4 locations)
- B** AC circuit breaker - electric winch (if equipped)
Controls export power (if equipped)
- C** DC circuit breaker (3 locations)
- D** Controller power switch
- E** Main circuit breaker
- F** Mast UP-DOWN switch (if equipped)
- G** Engine hour meter
Displays how many hours engine has run
- H** Power Zone Autolight controller

Power Zone Autolight with Import Power (If Equipped)

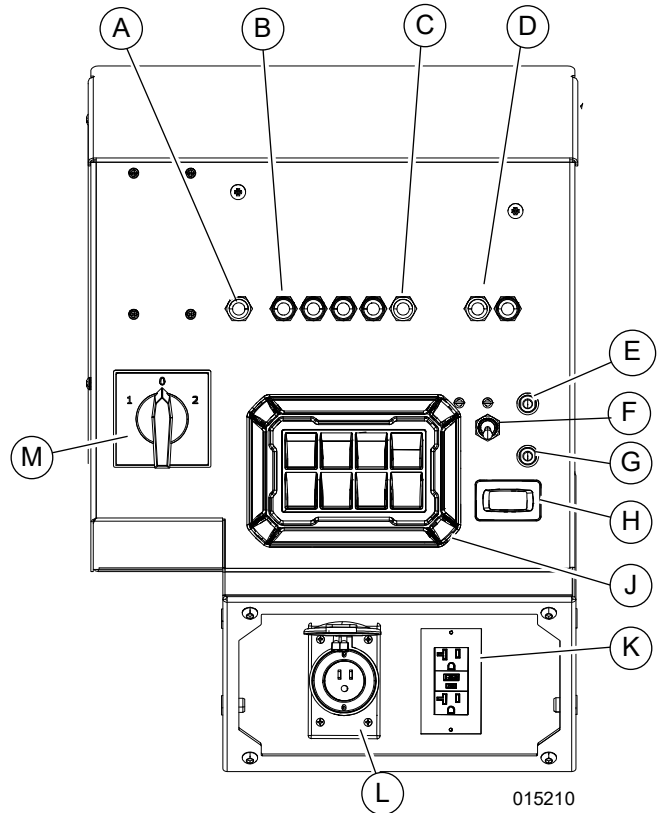

Figure 2-14. Optional Power Zone Autolight Controls With Optional Import Power

- A** GFCI breaker (if equipped)
- B** AC circuit breaker—light fixture (4 locations)
- C** AC circuit breaker
Controls export power (if equipped)
- D** DC circuit breaker (3 locations)
- E** Controller power switch
- F** Main circuit breaker
- G** Mast UP-DOWN switch (if equipped)
- H** Engine hour meter
Displays how many hours engine has run
- J** Power Zone Autolight controller
- K** Outlet receptacle (5-20R GFC)
- L** Inlet receptacle (5-15P)
- M** Engine/Utility power selector switch (flex switch)

Power Zone Autolight Controller (If Equipped)

See [Figure 2-15](#). The Power Zone Autolight controller monitors vital unit functions, and indicates operational status and fault conditions.

The controller can be set to automatic (AUTO) mode, in which the lights and engine automatically start and stop according to input from the dusk-to-dawn sensor.

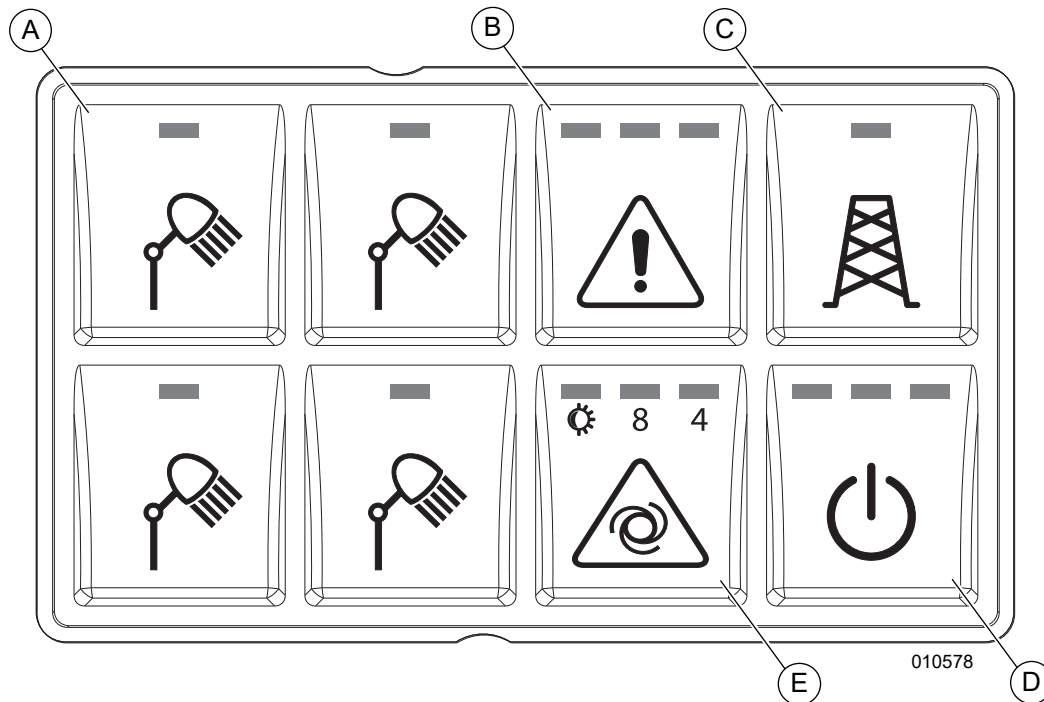

Figure 2-15. Power Zone Autolight Controller

- | | |
|---|-----------------------------------|
| A Light fixture ON-OFF button (4 locations) | D Engine START-STOP button |
| B Fault indicator button | E AUTO mode button |
| C UTILITY mode button (functions on units equipped with this option) | |

(A) Light Fixture ON-OFF Button (4 locations)

See [Figure 2-16](#). These buttons control power to the light fixtures. One button controls one light fixture, as illustrated.

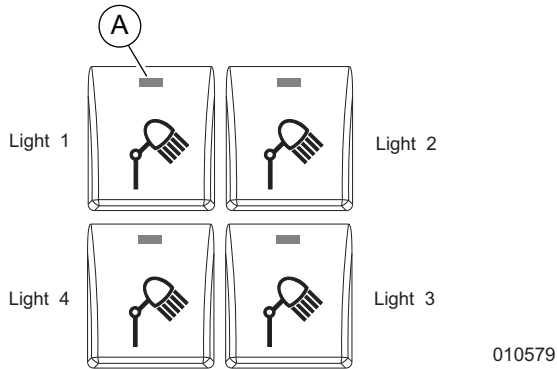

Figure 2-16. Light Fixture ON-OFF Buttons

- Each button contains an LED (A). If an LED is illuminated, the corresponding light fixture is powered.
- Each button is single-push: Press once to switch the corresponding light ON or OFF.

NOTE: If any light does not function as described, see [Troubleshooting](#).

(B) Fault Indicator Button

See [Figure 2-17](#). This button resets faults indicated by the LEDs (A, B, C). To reset a fault, press and hold for 3 seconds.

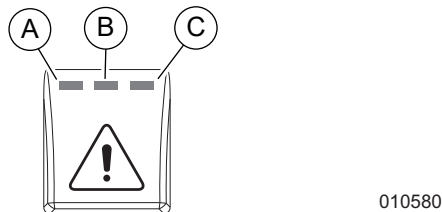

Figure 2-17. Fault Indicator Button

Illuminate LED	Indicates Fault
A	Engine fault
B	Low battery
C	Fail to crank (AUTO mode only)
A and C	Engine overspeed or engine underspeed
B and C	Loss of speed signal

See [Troubleshooting](#) for more information.

(C) UTILITY Mode Button

NOTE: This button only functions in units equipped with UTILITY mode.

See [Figure 2-18](#). This button controls UTILITY mode. Press the button to switch UTILITY mode ON or OFF.

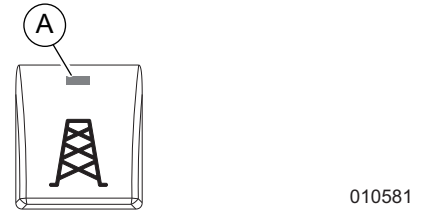

Figure 2-18. UTILITY Mode button

When the LED (A) is illuminated, UTILITY mode is ON.

(D) Engine START-STOP Button

See [Figure 2-19](#). This button controls start-up and shut-down. Press once button to start or stop the engine and generator (genset).

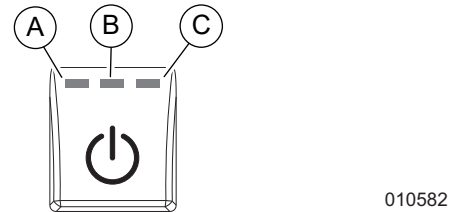

Figure 2-19. Engine START-STOP Button

Illuminate LED	Indicates
A	Unit is starting or running
B	Glow plugs active
C	Engine cranking

(E) AUTO mode button

See [Figure 2-19](#). This button controls whether the unit starts/stops automatically or is operator-controlled. When AUTO mode is active, the unit starts and stops on an operator-defined schedule, as shown below.

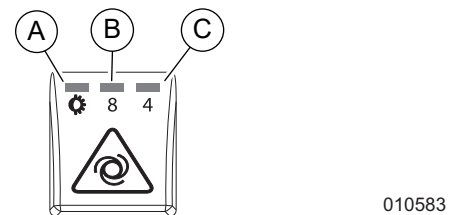

Figure 2-20. AUTO Mode Button

Illuminate LED	Indicates
A	Automatic dusk to dawn
B	Schedule 1: Dusk + 8 hr
C	Schedule 2: Dusk + 4 hr

About UTILITY Mode (If Equipped)

Units equipped with UTILITY mode can provide lighting without running the genset.

Requirements for UTILITY mode are:

- 120 V, Utility or generator power supply
- 120Vac
- Non GFCI Utility or Generator 15A receptacle
- 5-15 (12/3) extension cord - 100 ft max.

NOTE: In UTILITY mode, the engine does not start.

About SLEEP Mode (If Equipped)

Units equipped with Power Zone Autolight controls are also equipped with SLEEP mode.

- If controller power is ON, the unit is not running, and no button is pressed for 180 seconds, the controller enters SLEEP mode.
- To wake unit from SLEEP mode, press any button.

Engine Derating

All units are subject to derating for altitude and temperature. Derating reduces the available power for operating tools and accessories connected to the receptacles. For every increase in 1,000 ft (305 m) of elevation, engine performance for this unit typically drops between 2–4%. Also, engine performance decreases about 1% for every 10 °F (5.6 °C) increase in ambient air temperature over 72 °F (22 °C).

THIS PAGE INTENTIONALLY LEFT BLANK

Section 3: Operation

Unit Setup

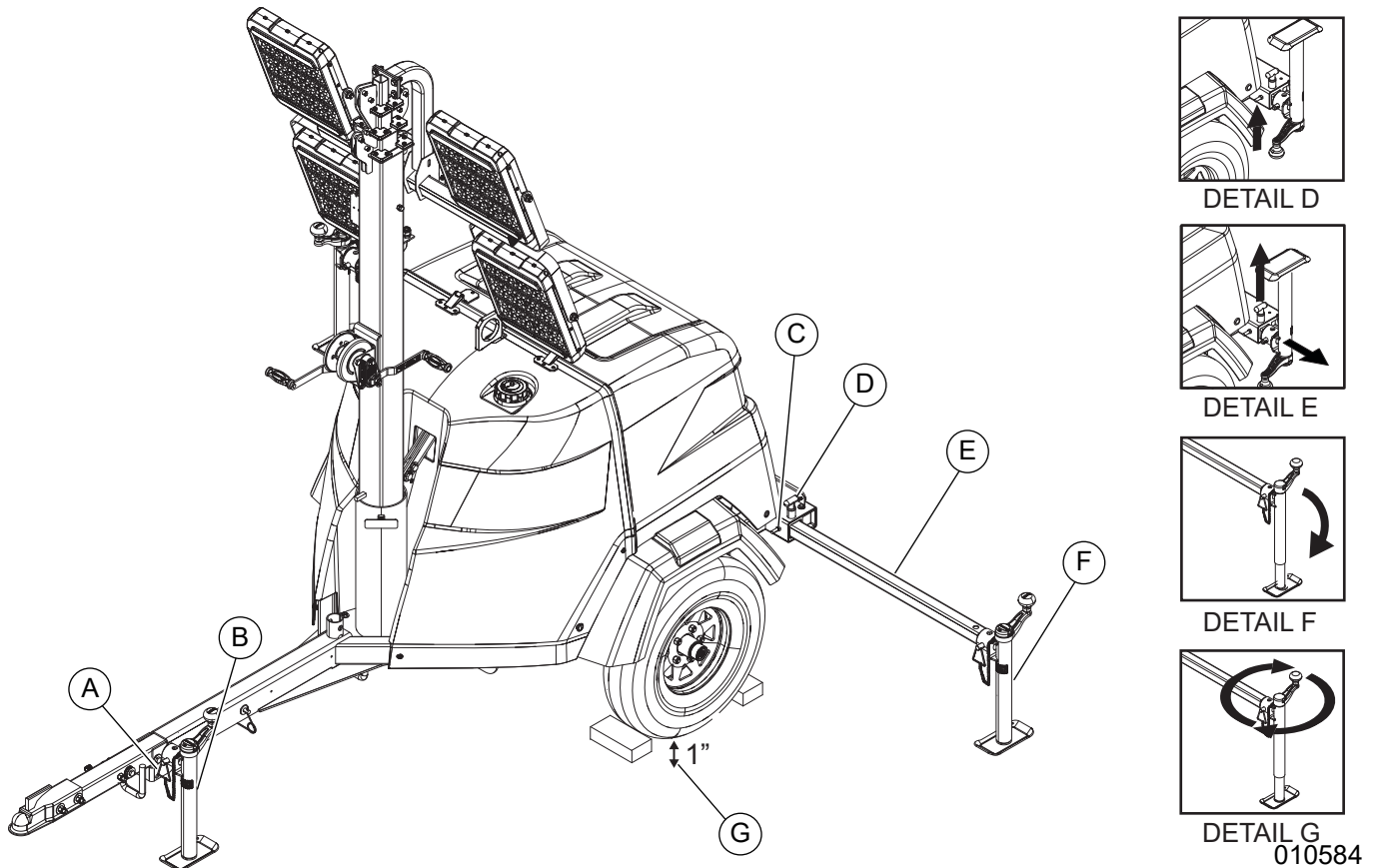

Figure 3-1. Setup Components



⚠ DANGER

High Voltage. Verify area above unit is clear of overhead wires and obstructions. Contact with high-voltage power lines will result in death or serious injury.

(000260a)



⚠ WARNING

> 65 mph Do not set up the unit if high winds are expected. High winds can cause the unit to tip or fall, causing severe injury or machine damage.

(000297)

1. For maximum light coverage, position the unit at ground level or in a spot higher than the area being illuminated by the lamps.

NOTE: See [Component Locations](#) for unit height.

2. See [Figure 3-1](#). Place the unit on firm ground that is relatively flat (less than 5° slope), and block the

wheels to keep it from moving. This will make it easier to level the unit.

3. Pull the locking pin (A) on the tongue jack (B) and rotate the jack 90°. Install the locking pin. Rotate the jack handle clockwise to raise the trailer tongue off the towing vehicle.
4. A grounding stud (C) is located on the rear frame of the trailer near the left side outrigger. For grounding requirements, follow local, state, and National Electrical Code (NEC) regulations.
5. See Details D–E. Pull the locking pins (D) on the outriggers (E) and pull each outrigger out until the spring loaded locking pin snaps back into place. Pull the locking pin on each outrigger jack (F) and rotate each jack 180° until the jack pad is facing down. Install the locking pin.
6. See detail G. Rotate each jack handle clockwise to start leveling the trailer. Adjust all three jacks by rotating the handles clockwise until they are firmly in contact with the ground. Continue until the wheels are approximately 1 in (2.5 cm) off the ground (G).

7. Before raising the mast, it may be necessary to adjust the lamps. The lamps may be adjusted up, down, left or right by simply aiming them in the desired direction.

Raising the Mast - Manual Winch



⚠ DANGER

Electrocution. DO NOT use the unit if electrical cord is cut or worn through. Doing so will result in death or serious injury.

(000263a)

⚠ WARNING

Tipping hazard. Extend the outriggers and level the unit before raising the mast. Keep the outriggers extended while the mast is up. Failure to do so could cause the unit to tip and fall and could result in death or serious injury.

(000266)

⚠ WARNING

Tipping hazard. Do not extend the mast beyond the colored mark on the second mast section. The unit can become unstable and tip or fall, causing injury.

(000262)

⚠ WARNING

Personal Injury. Stop immediately if the mast hangs up or the winch cable develops slack. Excess slack could cause the mast to collapse, resulting in personal injury or equipment damage.

(000265)

⚠ WARNING

Personal injury or equipment damage. Do not raise or lower the mast while the unit is operating. Doing so can break the lenses and cause the lamps to shatter.

(000279)

1. Set up and level the unit. See [Unit Setup](#).
2. See [Figure 3-2](#) Prior to raising the mast inspect all cables including at the winch cable guard (D) through the viewing holes on side of the cable guard.
3. Ensure cables are centered in pulleys (A).
4. Raise the mast by slowly cranking winch handles (B). Verify the coiled electrical cord extends at the top sections of the mast.
5. Mast is fully extended when positive stop bolts prevent winch rotation.
6. Rotate the mast by loosening the mast rotation knob (C) at the bottom of the mast. Turn the mast until the lights face in the desired direction. Tighten

the mast rotation knob to secure the mast in position.

7. Using both hands, rotate the winch (B) to slowly extend the mast. Verify the coiled electrical cord is extending at the top sections of the mast. Stop extending the mast when the colored mark (D) on the second mast section is visible.

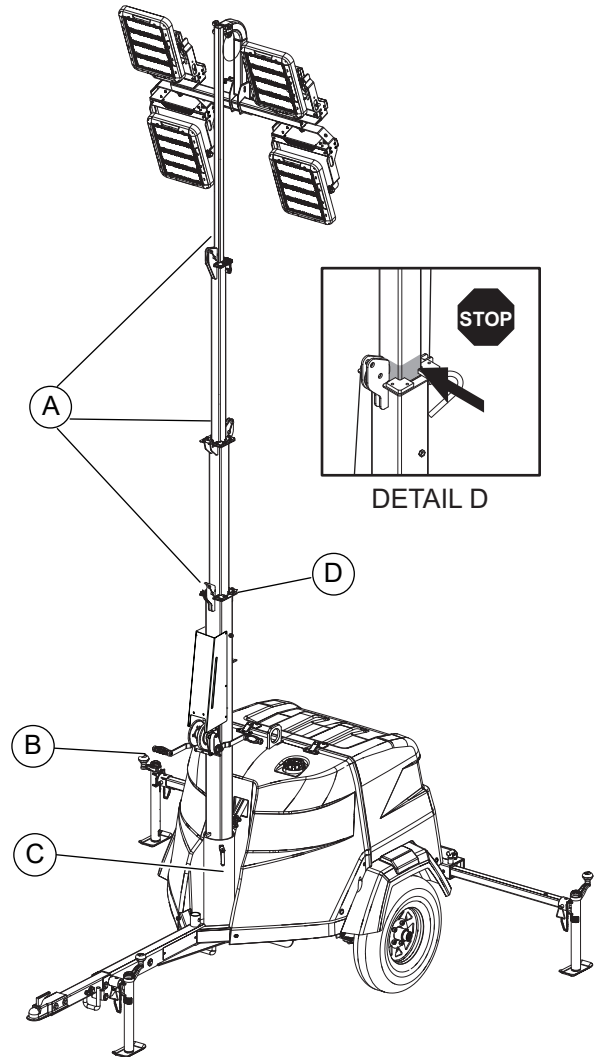

008709

Figure 3-2. Pulley Locations—Manual Winch

IMPORTANT NOTE: Contact a GMASD immediately if the mast hangs up or the winch cable develops slack.

Mast Brake (If Equipped)

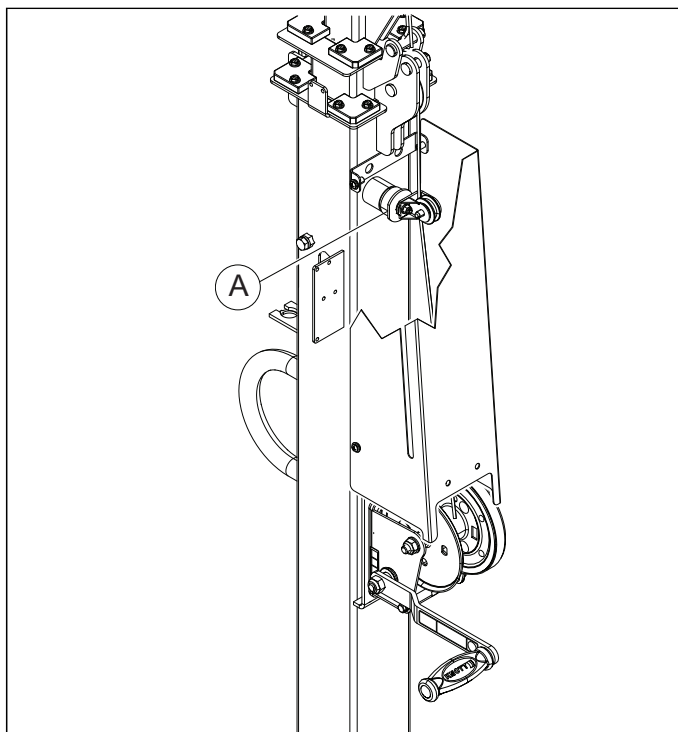

Figure 3-3. Mast Brake

1. See [Figure 3-3](#). Units equipped with a mast brake (A).
2. If mast brake engages due to mast being lowered at too fast of a rate simply stop lowering mast with winch and begin raising the mast slightly this will disengage the pin from the mast and allow further lowering of the mast.

IMPORTANT NOTE: To ensure proper operation of the mast brake device, during wet/cold operation check mast brake prior to operation to ensure no build up of ice on the device.

IMPORTANT NOTE: Ensure cable on winch spool does not become loose. If the winch cable becomes loose, it can cause the cable to lay in manner that can cause damage to the cable, i.e. kinking or fraying.

⚠ WARNING

Personal Injury. Stop immediately if the mast hangs up or the winch cable develops slack. Excess slack could cause the mast to collapse, resulting in personal injury or equipment damage. (000265)

⚠ WARNING

Personal injury or equipment damage. Do not raise or lower the mast while the unit is operating. Doing so can break the lenses and cause the lamps to shatter. (000279)

IMPORTANT NOTE: Contact a GMASD immediately if the mast hangs up or the winch cable develops slack or mast brake has engaged due to a winch cable failure.

Raising the Mast—Electric Winch (If Equipped)



⚠ DANGER

Electrocution. DO NOT use the unit if electrical cord is cut or worn through. Doing so will result in death or serious injury.

(000263a)

⚠ WARNING

Tipping hazard. Extend the outriggers and level the unit before raising the mast. Keep the outriggers extended while the mast is up. Failure to do so could cause the unit to tip and fall and could result in death or serious injury.

(000266)

⚠ WARNING

Tipping hazard. Do not extend the mast beyond the colored mark on the second mast section. The unit can become unstable and tip or fall, causing injury.

(000262)

⚠ WARNING

Personal Injury. Stop immediately if the mast hangs up or the winch cable develops slack. Excess slack could cause the mast to collapse, resulting in personal injury or equipment damage.

(000265)

⚠ WARNING

Personal injury or equipment damage. Do not raise or lower the mast while the unit is operating. Doing so can break the lenses and cause the lamps to shatter.

(000279)

1. Set up and level the unit. See [Unit Setup](#).

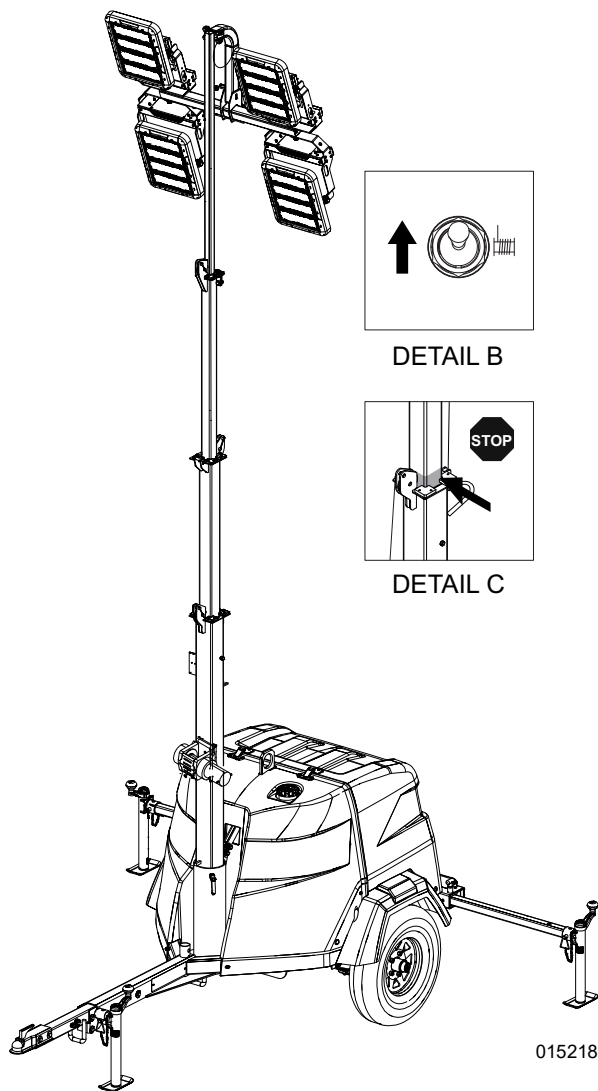

Figure 3-4. Switch & Pulley Locations—Electric Winch

2. See [Figure IMPORTANT NOTE](#): Inspect the mast cables for excessive wear or damage. Verify the cables are properly centered in each pulley (A). Inspect the electrical cord for damage.
3. Rotate the mast by loosening the mast rotation knob at the bottom of the mast (D). Turn the mast until the lights face in the desired direction. Tighten the mast rotation knob to secure the mast in position.

NOTE: On Key Switch models, key must be in RUN position to operate electric winch.

4. Press and hold the winch control switch (Detail B) upward to telescope the mast to the desired height. While doing so, verify that the coiled electrical cord is extending at the top sections of the mast. Stop extending the mast when the colored mark (C) on the second mast section is visible (Detail C).

IMPORTANT NOTE: A limit switch on the main mast section will disconnect power to the electric winch to prevent overextending the mast.

IMPORTANT NOTE: Contact a GMASD immediately if the mast hangs up or the winch cable develops slack.

Prestart Checklist

Before starting the unit, all items in the prestart checklist must be completed. This checklist applies to both manual and remote starting of the unit.



WARNING

Consult Manual. Read and understand manual completely before using product. Failure to completely understand manual and product could result in death or serious injury. (000100a)

- Verify all maintenance procedures are up to date. For more information, refer to [General Maintenance](#) and [Basic Maintenance Schedule](#).
- Perform a walk-around inspection. Refer to [Daily Walk-Around Inspection](#).
- The unit must be level.
- The unit must be dry. Inspect for water inside or near the unit; dry if needed.
- For grounding requirements, follow the National Electrical Code (NEC), state, and local regulations.
- Verify the control power switch is OFF (O).
- Verify all circuit breakers are OFF (O).
- Check that mast brake pin moves freely.
- Check that mast brake pulley rotates freely.
- Inspect all electrical cords; repair or replace any that are cut, worn, or bare.
- Verify all winch cables are in good condition and centered on each pulley. Do not use if cables are kinked or beginning to unravel.
- Check oil, coolant, and fuel levels. For more information, refer to [General Maintenance](#).
- Verify battery connections are secure.
- Turn the battery disconnect switch on, if equipped.
- Inspect the engine fan belt tension and condition.
- Inspect the engine fan belt guard.
- Inspect the engine exhaust system for loose or rusted components.
- Verify all covers are in place and secure.

Starting Unit - Analog Controls



Equipment Damage. Do not continuously crank engine for more than ten seconds. Doing so will lead to overdischarge of batteries and starter seizure.

(000230)

NOTE: If the engine was run out of fuel or the fuel tank was drained, it may be necessary to purge the fuel lines. Refer to the engine operator's manual supplied with the unit.

1. Open unit hood.
2. See [Figure 3-5](#). Switch the flex switch (if equipped) to position 2.

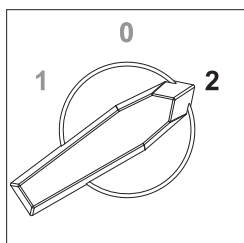

Figure 3-5. Flex Switch—Position 2

010585

3. Close unit hood.
4. See [Figure 3-6](#). Switch lights to OFF (O).

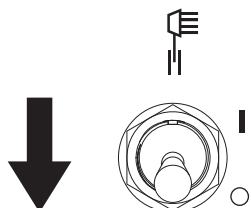

Figure 3-6. Lights OFF (O)

010586

5. See [Figure 3-7](#). Switch main AC circuit breaker to OFF (O).

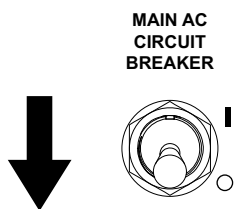

Figure 3-7. Main AC Circuit Breaker OFF (O)

010587

6. See [Figure 3-8](#). Turn ignition switch to GLOW PLUG position and hold for 10 to 15 seconds

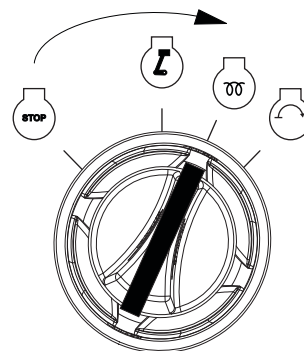

Figure 3-8. Activate Glow Plug

009951

IMPORTANT NOTE: Do not hold ignition switch in GLOW PLUG position for more than 15 seconds.

7. See [Figure 3-9](#). Turn ignition switch to START position and hold (10 seconds maximum) until engine cranks and starts.

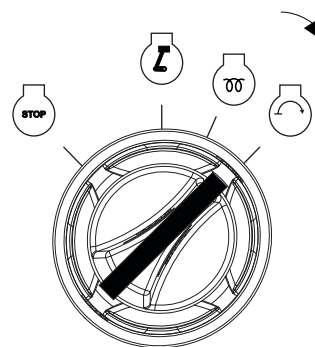

Figure 3-9. Crank Engine

009952

IMPORTANT NOTE: Do not crank engine for more than 10 seconds.

8. See [Figure 3-10](#). Release ignition switch. It moves to the RUN position.

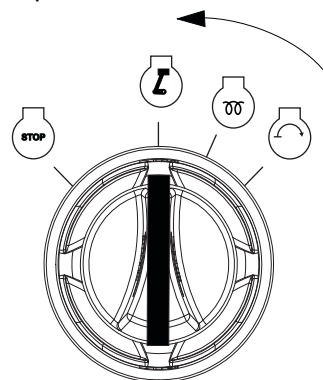

Figure 3-10. Release Key

009953

IMPORTANT NOTE: If unit does not start after 10 seconds of cranking, turn ignition switch to STOP position and wait 30 seconds. Then, repeat steps 6–7 as necessary.

9. Begin using lights and receptacles (if equipped), in accordance with the following:
 - To operate lights, see [Operating Lights - Analog Controls](#).
 - To operate 120 V convenience receptacles, see [Customer Convenience Receptacles \(If Equipped\)](#).

Starting Unit - Power Zone Autolight Controls (Manual Mode)

NOTE: If the engine was run out of fuel or the fuel tank was drained, it may be necessary to purge the fuel lines before starting. See the OEM engine manual supplied with the unit.

1. Open unit hood.
2. See [Figure 3-11](#). Switch the flex switch (if equipped) to position 2.

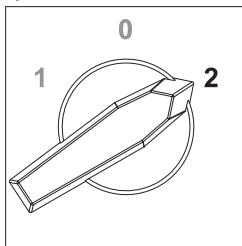

010585

Figure 3-11. Flex Switch—Position 2

3. Close unit hood.
4. See [Figure 3-12](#). Switch controller power to ON (I).

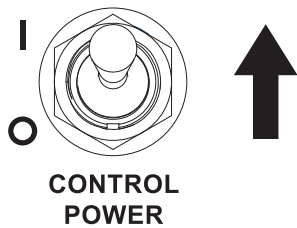

010588

Figure 3-12. Controller Power ON (I)

5. See [Figure 3-13](#). Press the START-STOP button.

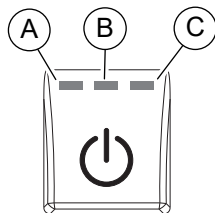

010582

Figure 3-13. Engine START-STOP Button

NOTE: The LEDs (A, B, C) allow the operator to monitor start-up progression. See table below.

- | | |
|----------|--|
| A | illuminates when START-STOP button is pushed. Remains illuminated during start-up process and while engine is running. |
| B | Flashes when glow plugs are active. |
| C | illuminates when engine cranks. |
6. Begin using lights and receptacles (if equipped), in accordance with the following:
 - To operate lights, see [Operating Lights - Power Zone Autolight Controls \(MANUAL Mode\)](#).
 - To operate 120 V convenience receptacles, see [Customer Convenience Receptacles \(If Equipped\)](#).

Starting Unit - Power Zone Autolight Controls (AUTO Mode)

1. See [Figure 3-14](#). Switch controller power to ON (I).

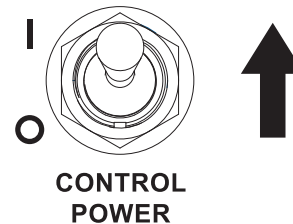

010588

Figure 3-14. Controller Power ON (I)

2. See [Figure 3-15](#). Switch main circuit breaker to ON (I).

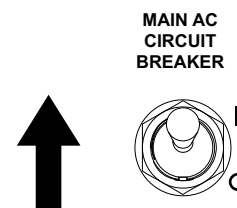

010589

Figure 3-15. Main AC Circuit Breaker ON (I)

3. See [Figure 3-16](#). Press AUTO mode button until desired schedule is active. See [AUTO Run Scheduling](#).

NOTE: Due to function of the schedule, the unit might not start immediately.

AUTO Run Scheduling

AUTO mode requires a schedule for running and shutting off, which the operator must assign.

See [Figure 3-16](#). Three schedules are available. The active schedule is indicated by an illuminated LED on the AUTO mode button.

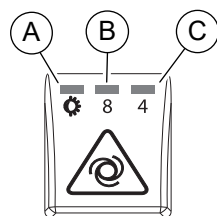

010583

Figure 3-16. AUTO Mode Button—LEDs

- A** Automatic dusk to dawn.
Engine and lights start and stop in accordance with ambient brightness at the dusk-to-dawn sensor.
- B** Schedule 1: Dusk + 8 hours.
Eight-hour engine-run/lighting period, starting at dusk. Repeats daily.
- C** Schedule 2: Dusk + 4 hours.
Four-hour engine-run/lighting period, starting at dusk. Repeats daily.

NOTE: The dusk-to-dawn setting (A) utilizes an adjustable dusk-to-dawn sensor. See [Dusk-to-Dawn Sensor \(If Equipped\)](#).

Operating Lights - Analog Controls

1. Verify the unit is ON and running smoothly. See [Starting Unit - Analog Controls](#).
2. See [Figure 3-17](#). Switch main circuit breaker to ON (I).

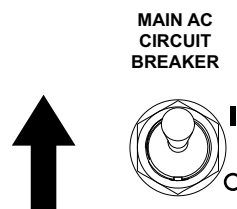

010589

Figure 3-17. Main Circuit Breaker ON (I)

3. See [Figure 3-18](#). Switch lights to ON (I).

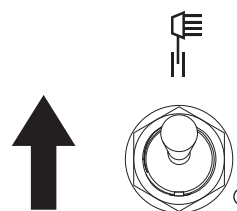

010590

Figure 3-18. Lights ON (I)

Operating Lights - Power Zone Autolight Controls (MANUAL Mode)

1. Verify the unit is ON and running smoothly. See [Starting Unit - Power Zone Autolight Controls \(Manual Mode\)](#).
2. Switch main circuit breaker to ON (I).
3. See [Figure 3-19](#). Press one or more light ON-OFF buttons.

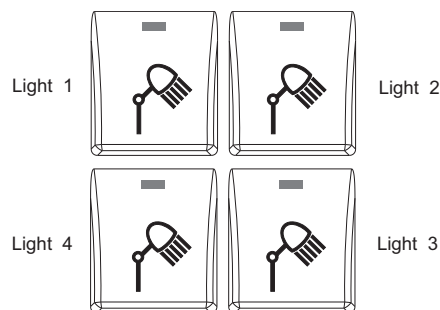

010579

Figure 3-19. Light Fixture ON-OFF Buttons

NOTE: If the main circuit breaker is OFF, the light fixture ON-OFF button LED (A) illuminates but the light fixture does not. Switch main circuit breaker ON.

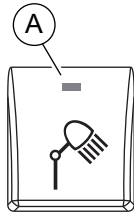

010591

Figure 3-20. Light Fixture ON-OFF Button

Operating Lights - Power Zone Autolight Controls (AUTO Mode)

In AUTO mode, light fixtures automatically switch ON, according to the active schedule. Change which lights switch ON by pressing one or more light ON-OFF buttons ([Figure 3-19](#)).

Shutting Down Unit - Analog Controls

1. Stop using and unplug equipment from the 120 V convenience receptacles. See [Removing Loads from Receptacles \(If Equipped\)](#).
2. See [Figure 3-21](#). Switch lights to OFF (O).

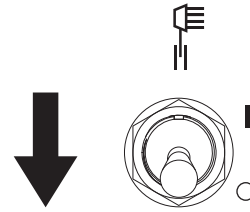

010586

Figure 3-21. Lights Switch

3. See [Figure 3-22](#). Switch main AC circuit breaker to OFF (O).

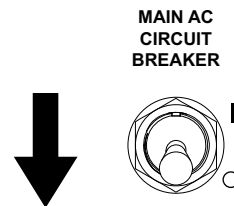

010587

Figure 3-22. Main AC Circuit Breaker OFF (O)

4. See [Figure 3-23](#). Turn ignition switch to STOP position.

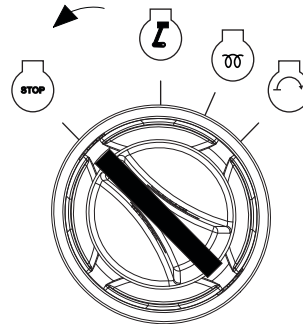

010594

Figure 3-23. Stop Engine

5. Open unit hood.
6. See [Figure 3-24](#). Switch the flex switch (if equipped) to position 0.

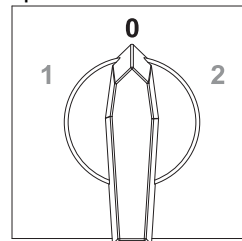

010595

Figure 3-24. Flex Switch—Position 0

7. Close unit hood.

Shutting Down Unit - Power Zone Autolight Controls (MANUAL Mode)

1. Remove all loads from receptacles. See [Removing Loads from Receptacles \(If Equipped\)](#).
2. See [Figure 3-25](#). Switch OFF (O) lights by pressing the light ON-OFF buttons.

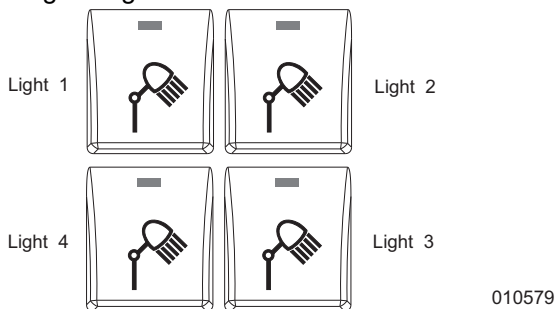

Figure 3-25. Light Fixture ON-OFF Buttons

3. See [Figure 3-26](#). Switch main AC circuit breaker to OFF (O).

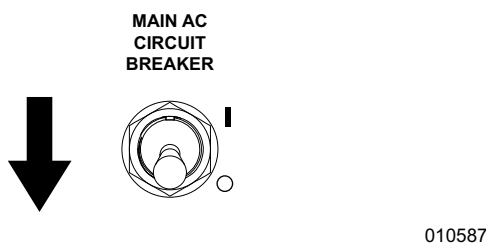

Figure 3-26. Main AC Circuit Breaker OFF (O)

4. See [Figure 3-27](#). Press the engine START-STOP button once.

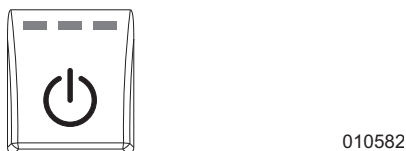

Figure 3-27. Engine START-STOP Button

NOTE: Engine begins cool-down cycle, shutting off when engine is sufficiently cool.

NOTE: To skip cool-down cycle, press the ENGINE START-STOP button twice instead of once.

5. See [Figure 3-28](#). Switch controller power switch to OFF (O).

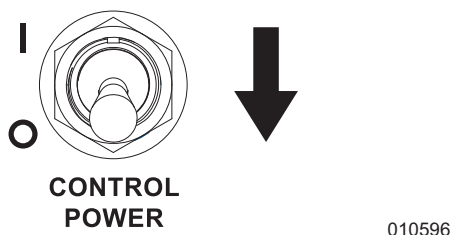

Figure 3-28. Controller Power—OFF (O)

Shutting Down Unit - Power Zone Controls (AUTO Mode)

NOTE: In AUTO mode, the unit automatically shuts down, in accordance with the active schedule.

IMPORTANT NOTE: This procedure cancels AUTO mode and shuts down the unit.

1. Remove all loads from receptacles. See [Removing Loads from Receptacles \(If Equipped\)](#).
2. See [Figure 3-29](#). Switch lights OFF (O) by pressing the light ON-OFF buttons.

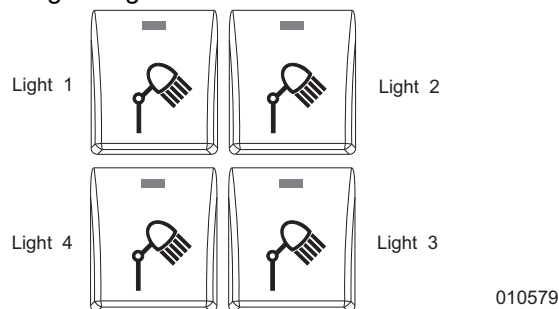

Figure 3-29. Light Fixture ON-OFF Buttons

See [Figure 3-30](#). Press AUTO mode button until all controller LEDs (A, B, and C) are OFF.

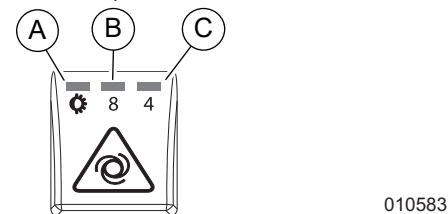

Figure 3-30. AUTO Mode Button—LEDs

3. See [Figure 3-31](#). Switch main AC circuit breaker to OFF (O).

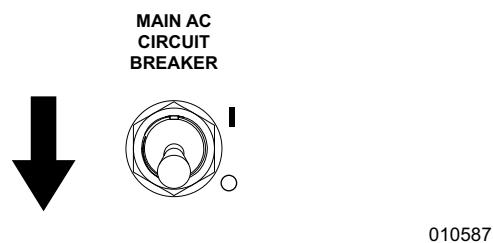

Figure 3-31. Main AC Circuit Breaker OFF (O)

NOTE: See [Figure 3-32](#). Press the engine START-STOP button once.

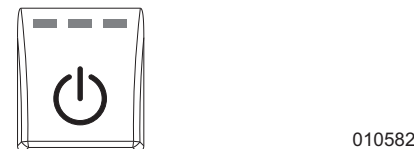

Figure 3-32. Engine START-STOP Button

NOTE: Engine begins cool-down cycle, shutting off when engine is sufficiently cool.

NOTE: To skip cool-down cycle, press the ENGINE START-STOP button twice.

- See **Figure 3-33**. Switch controller power switch to OFF (O).

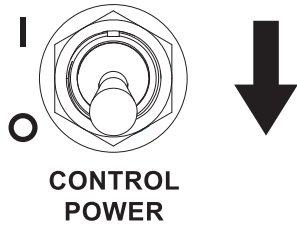

Figure 3-33. Controller Power—OFF (O)

010596

Automatic Shutdown

This unit is equipped with a low oil pressure and high coolant temperature automatic shutdown system. This system automatically shuts off the fuel supply to stop the engine if oil pressure drops too low, or the engine exceeds normal operating temperature. Return the main circuit breaker to STOP to reset the unit after the cause of shutdown has been determined.

Starting Utility Mode (If Equipped - Power Zone Autolight Controls)

- Shut down the unit (if applicable).
- Open unit hood.
- See **Figure 3-34**. Switch the flex switch (if equipped) to position 0.

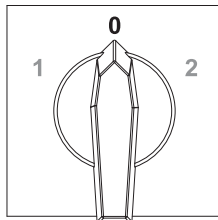

Figure 3-34. Flex Switch—Position 0

010595

- See **Figure 3-35**. Switch main AC circuit breaker to OFF (O).

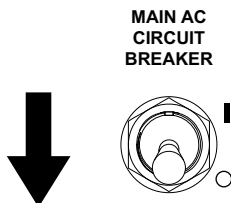

Figure 3-35. Main AC Circuit Breaker OFF (O)

010587

- See **Figure 3-36**. Switch controller power to OFF (O).

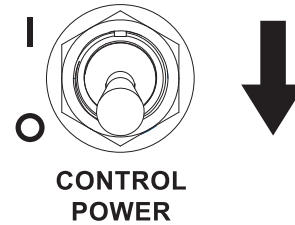

Figure 3-36. Controller Power OFF (O)

010596

- See **Figure 3-37**. Install 120 V, NEMA 5-15 cord to unit power inlet port.

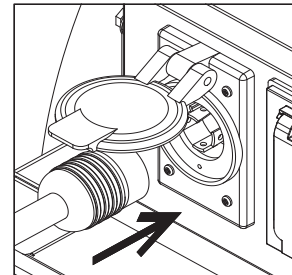

Figure 3-37. Utility Cord Installation to Unit

010597

- Install 120 V, NEMA 5-15 cord to utility power source.
- See **Figure 3-38**. Switch the flex switch (if equipped) to position 1.

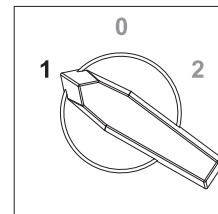

Figure 3-38. Flex Switch—Position 1

010598

- See **Figure 3-39**. Switch controller power to ON (I).

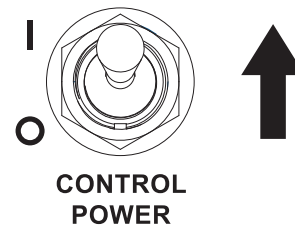

Figure 3-39. Controller Power ON

010588

- See **Figure 3-40**. On controller, activate utility mode by pushing the Utility Mode button.

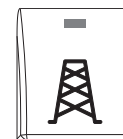

Figure 3-40. Utility Mode Button

010581

NOTE: When utility mode is activated, the LED (A) switches on.

- See [Figure 3-41](#). Switch main circuit breaker to ON (I).

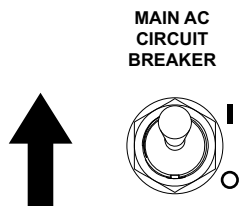

Figure 3-41. Main AC Circuit Breaker ON (I)

010589

- See [Figure 3-42](#). Switch lights ON (I) by pressing the light ON-OFF buttons.

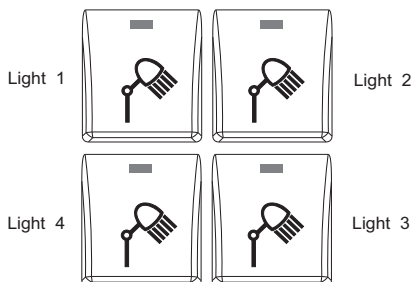

Figure 3-42. Light Fixture ON-OFF Buttons

010579

- Close unit hood.

Stopping Utility Mode (If Equipped) - Power Zone Controls

- Open unit hood.
- Remove all loads from receptacles. See [Removing Loads from Receptacles \(If Equipped\)](#).
- See [Figure 3-43](#). Switch lights OFF (O) by pressing the light ON-OFF buttons.

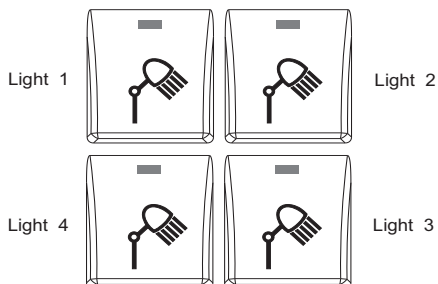

Figure 3-43. Light Fixture ON-OFF Buttons

010579

- See [Figure 3-44](#). Switch main AC circuit breaker to OFF (O).

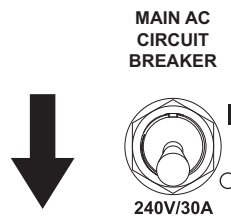

Figure 3-44. Main AC Circuit Breaker OFF (O)

010587

- See [Figure 3-45](#). On controller, deactivate utility mode by pushing the Utility Mode button.

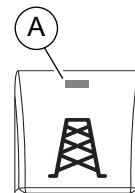

Figure 3-45. Utility Mode Button

010581

NOTE: When utility mode is deactivated, the LED (A) is OFF.

- See [Figure 3-46](#). Switch controller power to OFF (O).

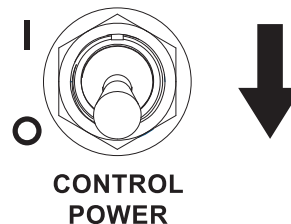

Figure 3-46. Controller Power Switch

010596

- See [Figure 3-47](#). Switch the flex switch (if equipped) to position 0.

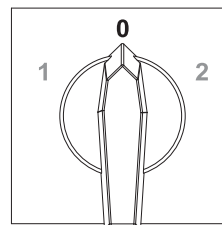
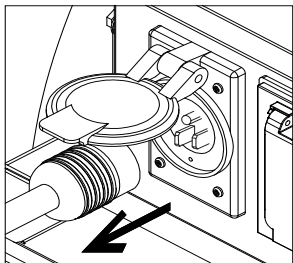

Figure 3-47. Flex Switch—Position 0

010595

- See [Figure 3-48](#). Remove 120 V, NEMA 5-15 cord from unit power inlet port.



015148

Figure 3-48. Utility Cord Removal from Unit

- Close unit hood.

Dusk-to-Dawn Sensor (If Equipped)

See [Figure 3-49](#). Units equipped with Power Zone Autolight controller are also equipped with a *dusk-to-dawn sensor* (A), which senses light and accordingly starts and stops the unit.

The sensor's perception of dusk and dawn can be adjusted, due to an adjustable light-shield equipped near the sensor.

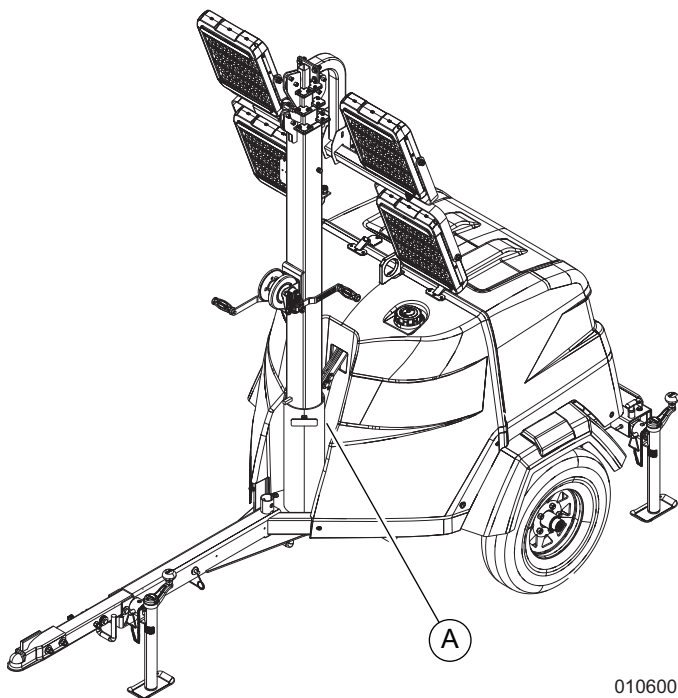

010600

Figure 3-49. Sensor, Shield Located Behind Mast

NOTE: The dusk-to-dawn sensor is only used when the controller is in AUTO mode and the active schedule is *Dusk to Dawn*.

Preparing Sensor for Use

Perform the following procedure at the time of day you want the lights to switch on.

- Verify controller is in AUTO mode and the active schedule is *Dusk to Dawn*. See [Starting Unit - Power Zone Autolight Controls \(AUTO Mode\)](#).
- Loosen screws on light shield.
- Slide the light-shield up, decreasing the sensor's exposure to light, until the lights turn on.
- Tighten screws on light shield.

Customer Convenience Receptacles (If Equipped)

NOTE: Convenience outlets (export power) do not work when the unit is in utility mode (diesel engine must be in operation).

See [Figure 3-50](#). The unit may be equipped with a 120V, 20 A, GFCI, duplex receptacle; for powering accessories or tools.



010601

Figure 3-50. Customer Convenience Receptacles

The receptacles, and a corresponding circuit breaker, are located on the control panel. See [Figure 2-11](#).

The receptacles are operable when the engine is running and the main circuit breaker is ON (I).

Load Limit and Overload

- Lights on: Load limit = 1,100 W
- Lights off: Load limit = 1,200 W

Drawing more than the load limit overloads the generator, resulting in main circuit breaker trip. If the breaker trips, switch off the lights and remove some load from the receptacle.

Removing Loads from Receptacles (If Equipped)

When shutting down the unit, remove loads from receptacles as follows.

- Notify personnel using unit-supplied power that shutdown is pending.
- Verify shutdown will not create hazards (by turning off equipment that needs to remain running, such as pumps and compressors).
- Remove loads from receptacles.

Storing the Unit

Disconnect the battery if the unit will be stored for an extended period. Refer to the engine operator's manual for additional extended storage procedures.

Lowering the Mast - Manual Winch

1. Shut down the lights and engine. See [Shutting Down Unit - Analog Controls](#).
2. Lower the mast.
3. Use the winch handles to collapse the mast to its lowest position. Verify the electrical cord does not get caught in, or pinched by, the mast while it is being lowered.

WARNING

Personal Injury. Stop immediately if the mast hangs up or the winch cable develops slack. Excess slack could cause the mast to collapse, resulting in personal injury or equipment damage. (000265)

IMPORTANT NOTE: Contact a GMASD immediately if the mast hangs up or the winch cable develops slack.

4. See [Figure 3-51](#). If the unit is going to be moved, rotate the mast so the lights face the rear of the unit.

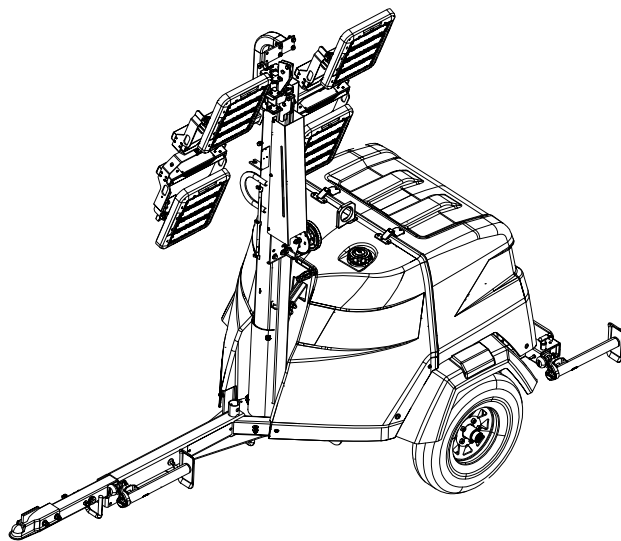

015217

Figure 3-51. Stowed (Travel) Position

To rotate the mast:

- a. Loosen the mast rotation knob.
- b. Rotate the mast until the white arrows are aligned and the metal stop tabs are touching.

- c. Tighten the mast rotation knob.

Lowering the Mast - Electric Winch (If Equipped)

NOTE: On analog (key switch) models, key must be in RUN to operate electric winch.

1. Press and hold the upper winch control switch downward to collapse the mast to its lowest position. Verify the electrical cord does not get caught in, or pinched by, the mast while it is being lowered.
2. Shut down the engine. See [Shutting Down Unit - Analog Controls](#).
3. If the unit is going to be moved, rotate the mast so the lights face the rear of the unit. To rotate the mast:
 - a. Loosen the mast rotation knob.
 - b. Rotate the mast until the white arrows are aligned and the metal stop tabs are touching.
 - c. Tighten the mast rotation knob.

NOTE: The electric winch models are equipped with a safety limit switch. This switch disconnects power to the winch after the mast is completely raised or lowered. This prevents the cable from continuing to unwind and becoming entangled around the winch drum.

WARNING

Personal Injury. Stop immediately if the mast hangs up or the winch cable develops slack. Excess slack could cause the mast to collapse, resulting in personal injury or equipment damage. (000265)

IMPORTANT NOTE: Contact a GMASD immediately if the mast hangs up or the winch cable develops slack.

NOTE: If the light tower is not operational, and the batteries do not have enough power to lower the mast, it may be necessary to lower the mast manually. Always attempt to recharge the batteries and lower the mast electrically before proceeding.

Manually Lowering Electric Mast

IMPORTANT NOTE: Do not use this procedure unless it is absolutely necessary. Frequent use of this procedure could damage the motor shaft.

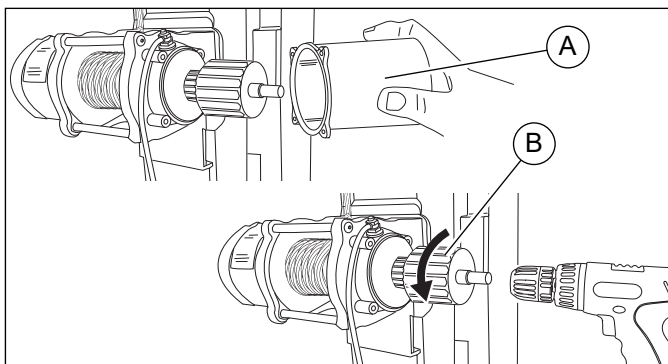

Figure 3-52. Manually Lowering the Mast

1. See **Figure 3-52**. Remove the motor cover (A).
2. Attach a drill chuck firmly to the exposed motor shaft (B).
3. Using the drill, slowly rotate the motor shaft counterclockwise to lower mast.
4. Detach the drill chuck and install the motor cover after the mast is completely lowered.

Positive Air Shutdown - PAS (If Equipped)

See **Figure 3-53**. This unit may be equipped with a positive air shutdown valve (A) on the air intake. The PAS system automatically stops the engine if an over speed is detected. Engine over speed can occur if the atmosphere contains elevated levels of combustible propane or natural gas.

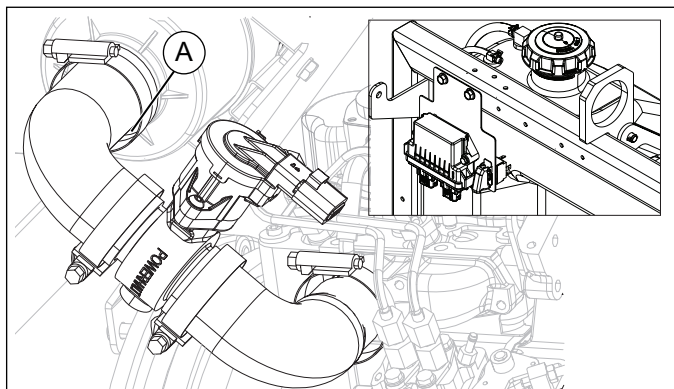

Figure 3-53. Positive Air Shutdown

The PAS system stops the engine by closing an internal valve and obstructing intake air. Shutdown is triggered automatically by an output from the controller or manually by pushing and releasing toggle switch.

Operation

- In over speed runaway condition, controller will automatically close valve and shut down engine

- Valve will remain closed for a minimum of 15 seconds and then automatically reset itself to open position.

Maintenance

To ensure trouble-free long life of PowerHalt Shut-Off Valve, scheduled monthly maintenance procedure is mandatory:

As this is a safety device, activation testing must be employed at a minimum of once per month to ensure system remains functional and valve is free moving. Daily activations are recommended to ensure proper function of the system.

- Inspect all fasteners, clamps, and support brackets for tightness and required torque
- Inspect all wiring / cable runs for corrosion, vibration wear, and loose connections
- Inspect all hoses for cracks, damage, and leaks
- Inspect controller for damage, dirt, and poor connections

Coolant Heater or Engine Block Heater (If Equipped)

- Optional coolant heater required to start unit below 0F (-17.8C) ambient temperatures. While the heater is designed to be operated overnight if necessary, 2–5 hours of heating just prior to starting is usually sufficient for proper engine starting.

NOTE: Use coolant heater only in its designated location. Incorrect use can damage the engine.

Proceed as follows when operating a unit equipped with a coolant heater.

1. Verify the unit is level to maintain correct orientation of the heater while it is in operation.
2. Verify the cooling system is full of the correct mixture of water and engine coolant before each heater use.
3. Use only an undamaged, outdoor rated, three-prong grounded 120 V extension cord with a minimum amperage rating of 10A. Connect the cord to a properly grounded 120 V GFCI outlet.
4. Before starting the engine, unplug the extension cord from the power first, then unplug the heater cord set from the extension cord.

Tandem Tow (If Equipped)

See [Figure 3-54](#). The tandem tow hitch option (A) allows the operator to tow a second MLTS Light Tower in series behind the unit equipped with the hitch.

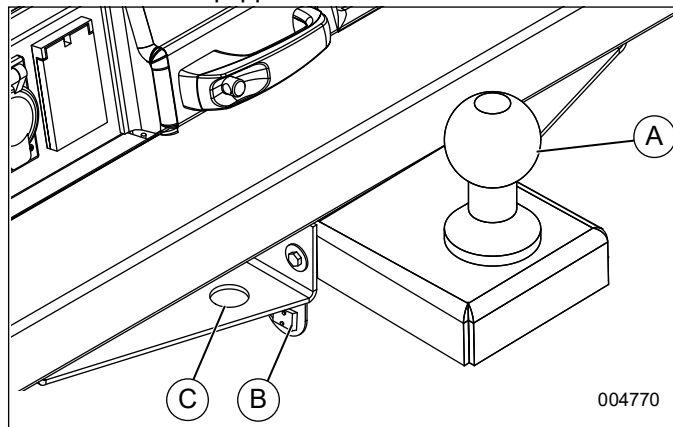

Figure 3-54. Tandem Tow

IMPORTANT NOTE: Never tow more than two units at once.

- Connect any trailer wiring to the unit in front (B). Inspect for proper operation of the directional and brake lights.
- Connect the towing chains to the tie down locations (C).
- Avoid sharp turns when towing. **Do not** cross any obstacles more than 12 in (30.5 cm) deep.
- See Tandem Tow Safety requirements: [Section 2](#).

Telemetry (If Equipped)

The digital telemetry option enables the operator to see machine status remotely. A transmitter inside the engine compartment sends real time equipment status information to the user via cellular or satellite connection.

Spark Arrester (If Equipped)

A spark arrester, installed on the unit exhaust, may be required by code in certain municipalities. Contact the local authority having jurisdiction to determine if a spark arrester must be installed on the unit before operation.

Heated Fuel Filter (If Equipped)

See [Figure 3-55](#). An optional heated fuel filter (A) prevents diesel fuel from gelling in extremely cold temperatures. Heating cycles are automatically controlled by the Power Zone Autolight.

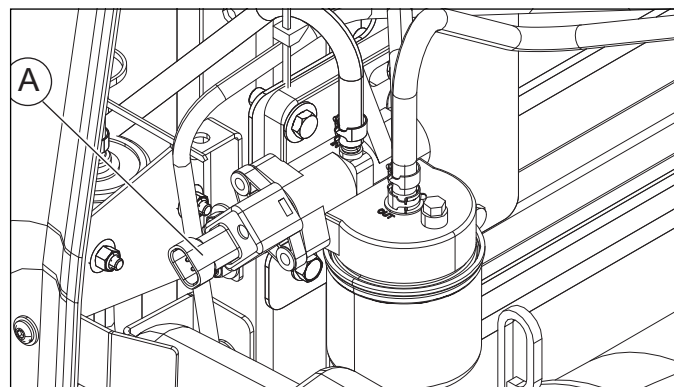

Figure 3-55. Heated Fuel Filter

Towing the Unit

Once the engine is shut down and the mast and lights are correctly stowed, proceed as follows to prepare the unit for towing.

1. Raise the outrigger jacks completely and release the locking pins to rotate them up into the travel position. Verify the locking pins snap into place. Release the outrigger locking pins and slide the outriggers into the trailer frame until the locking pins snap into place.
2. Use the tongue jack to raise or lower the trailer onto the hitch of the towing vehicle. Lock the hitch coupling and attach the safety chains or cables to the vehicle. Remove the tongue jack locking pin and rotate the jack into the travel position. Replace the locking pin.
3. To ensure correct operation of the jacks, refer to [Trailer Wheel Bearings](#). For maintenance interval information, refer to [Basic Maintenance Schedule](#).
4. Connect any trailer wiring to the tow vehicle. Inspect for correct operation of the directional and brake lights.
5. Verify the enclosure is correctly latched.
6. Check for correct inflation of the trailer tires. For maximum tire pressures, refer to [Specifications](#).
7. See [Figure 3-56](#). Inspect the wheel lugs. Tighten or replace any lugs that are loose or missing. If a tire has been removed for axle service or replaced, tighten the lugs, in the order shown, to the following specifications:
 - a. Start all lug nuts by hand.
 - b. First pass: tighten to 20-25 ft-lbs (27-33 Nm).
 - c. Second pass: tighten to 50-60 ft-lbs (67-81 Nm).
 - d. Third pass: tighten to 90-120 ft-lbs (122-162 Nm).

Figure 3-56. Tightening Wheel Lugs

NOTE: After the first road use, torque the lug nuts in sequence.

8. Maximum recommended speed for highway towing is 65 mph (105 km/h). Recommended off-road towing speed is not to exceed 10 mph (16 km/h) or less, depending on the terrain.

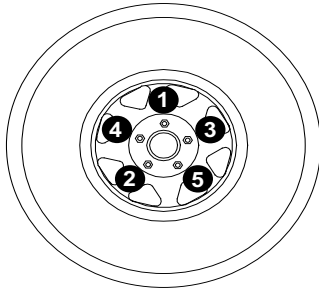

Lifting the Unit

Proceed as follows to prepare the unit for lifting:

1. Verify the equipment being used to lift the unit is in good condition and has sufficient capacity. For approximate weights, refer to **Specifications**.
 2. Close and lock all hoods and doors.
 3. See **Figure 3-57**. Stow the mast and lights in the travel position as shown.
 4. Always remain aware of people and objects around the unit while preparing, maneuvering, and lifting the unit.
- When lifting the unit, attach any slings, chains, or hooks directly to the central lift point (A). The central lift point is located on top of the enclosure, connected to a lift structure inside the unit.

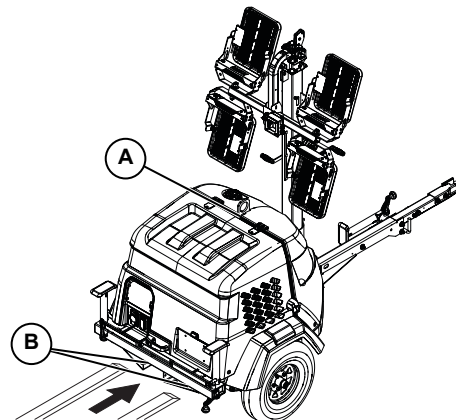

008714

Figure 3-57. Lifting Points

- Use the forklift pockets (B) with care. Lift directly from the rear. Avoid approaching the unit at an angle, as this can permanently damage the forklift pockets, tires, or cabinet. Verify any obstructions are clear of the forklift tines before lifting.

Tying Down the Unit

When securing the unit for transportation, verify the equipment being used to fasten the unit is in good condition and has sufficient strength to hold the unit in place during transport.

See [Figure 3-58](#). Use the tie-down points (C) as shown.

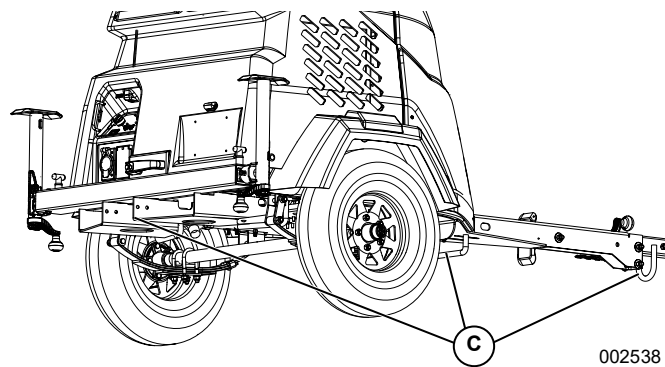

Figure 3-58. Tie-Down Points

THIS PAGE INTENTIONALLY LEFT BLANK

Section 4: Maintenance

Emissions Information

For warranty information, please refer to the diesel engine manual supplied with this unit.

Daily Walk-Around Inspection



Equipment Damage. Failure to perform a daily inspection could result in damage to the unit.

(000306)

Perform a walk-around inspection of the unit every day before starting the unit. Look for conditions that could hinder performance or safety, such as (but not limited to):

- Oil, coolant, and fuel leakage
- Blocked vents
- Loose or missing hardware
- Loose or broken electrical connections

Inspect the fan belt for cracks, fraying, or stretching. Verify the belt is correctly seated in the pulley grooves. Replace the belt according to the manufacturer's recommendations.

General Maintenance

Poorly maintained equipment can become a safety hazard. In order for the equipment to operate safely and correctly over a long period of time, periodic maintenance and occasional repairs are necessary. **DO NOT** perform routine service (oil and filter changes, cleaning, etc.) unless all electrical components are shut off.

Regular maintenance will improve performance and extend engine/equipment life. Generac Mobile recommends that all maintenance work be performed by a GMASD. Regular maintenance, replacement or repair of the emissions control devices and systems may be performed by any repair shop or person of the owner's choosing. However, to obtain emissions control warranty service free of charge, the work must be performed by a GMASD or authorized Mitsubishi® engine dealer depending on the repair. See the emissions warranty.

Preparing for Service

Before servicing the unit, always follow the instructions listed below.

1. If unit is equipped with the Power Zone controller, verify the main circuit breaker is OFF. Otherwise, verify the key switch is OFF.
2. Verify the circuit breakers are switched OFF (O).

3. Disconnect the negative (-) terminal on the battery.
4. Attach a "Do Not Start" sign to the control panel to signify that the unit is being serviced and reduce the chance of unauthorized use.

Cleaning the Unit



Equipment damage. Never spray water to clean unit. Do not introduce water into generator windings, terminals, or fuel system during the cleaning process. Doing so will result in equipment damage. (000325a)

Always clean the unit after each use to remove dust, grease, mud, or spilled fuel or oil. Use soft, clean rags to wipe the cabinet exterior and control panel. Low-pressure compressed air (less than 40 psi [276 kPa]) can also be used to remove dust and debris from the cabinet interior.

This unit contains sensitive electronic components that can be damaged by high pressure and heat. **Do not:**

- wash the unit with a high pressure hose or power washer.
- wash the engine block or fuel tank with a power washer or steam cleaner. Water may enter the cabinet and collect in the generator windings or other electrical parts, causing damage.

Inspecting the Unit

- If the unit is stored outside, inspect for water inside the cabinet and generator before each use. If wet, dry the unit thoroughly before starting.
- Inspect condition of electrical cords. **DO NOT** use the unit if insulation is cut or worn through.
- Verify winch cables are in good condition and centered on each pulley. **DO NOT** use a cable that is kinked or starting to unravel.
- Verify mast brake pin and pulley travel freely.
- Inspect cable at winch cable guard. Replace cable if more than four wires are broken in a 1.5 inch (3.8 cm) length section.
- Verify the wheel lugs are present and correctly tightened. Refer to [Towing Safety](#).
- Check the coolant level daily by inspecting the level in coolant overflow jug located near the radiator. Refer to the engine operator's manual for coolant recommendations and proper mixture. Normal operating level is between the 'full' and 'add' markings on the overflow jug.
- After engine is stopped and completely cool, coolant may be added directly to the coolant overflow jug.

- Check the oil level daily. Refer to the engine operator’s manual for the appropriate oil specification.
- Verify the oil is correct for special operating conditions such as a change in season or climate.
 - **DO NOT** start the unit if the engine oil level is below the ADD mark on the dipstick.
 - Normal operating level is in the cross-hatch pattern between the full and add markings on the dipstick.
 - Add oil only if the oil level is below the add mark on the bottom of the cross-hatch pattern on the dipstick. **DO NOT OVERFILL.**
- Check the fuel level.
- If the unit is connected to a remote start or transfer switch, verify the remote switch is off and tagged.

NOTE: If the engine was run out of fuel or the fuel tank drained, it may be necessary to purge the fuel lines. Refer to the engine operator’s manual supplied with the unit.

Basic Maintenance Schedule

Refer to the original equipment manufacturer’s operating manual for a complete list of maintenance requirements. Failure to comply with the procedures as described in the engine operator’s manual will nullify the warranty, decrease performance, and cause equipment damage or premature equipment failure. Maintenance records may be required to complete a warranty request.

Use the schedule in the following table as a guide for regular maintenance intervals. For additional or replacement copies of the engine operator’s manual, contact a GMASD.

Basic Maintenance Schedule

Item	Daily	First 50 Hr	Every 400 Hr	Every 500 Hr	Every 750 Hr	Every 1,000 Hr	As Required
Check oil level	◆						
Check coolant level	◆						
Check fuel level	◆						
Check tire pressure	◆						
Inspect wheel bearings	◆						
Inspect all electrical connections	◆						
Inspect radiator fins for debris; clean as required	◆						
Inspect light tower winch for proper operation	◆						
Inspect fan belt for tightness	◆						
Inspect radiator hoses and clamp bands	◆						
Replace fan belt					◆		
Replace engine oil and oil filter		◆				◆*	
Inspect and adjust belt and belt tension		◆			◆		
Replace fuel filter element			◆**				
Inspect battery condition					◆		
Replace air filter element					◆**		
Lubricate leveling jacks							◆
Purge air from fuel system							◆
Drain residual water from fuel filter							◆
Inspect Mast cables	◆						
Maintain winch—See Winch Maintenance.	◆						

* Generac Mobile recommends oil change intervals on the MLTS equipped with the Mitsubishi L2E Tier 4 engine be extended to 1,000 hours after initial break-in. The engine comes from the factory with a larger sump that holds 5.5 qts (5.2 L) of engine oil. After the initial 50 hour break-in and oil change, the sump, coupled with the larger oil filter, allows the engine to operate up to 1,000 hours between routine oil changes. Hot, humid, or dusty conditions can shorten engine oil service life, regardless of suggested oil change intervals. Always follow the recommendations of the OEM engine manual that was shipped with the unit for specific operating instructions. If further technical assistance is required, contact Generac Mobile Technical Service at 1-800-926-9768.

* Air and fuel filter maintenance schedule vary, according to environmental factors

Manual Winch: Use, Operation, and Maintenance

Prior to Use

Verify winch cables are in good condition and centered on each pulley. **DO NOT** use a cable that is kinked or starting to unravel.

- cable at winch cable guard. See Interior Components. Replace cable if more than four wires are broken in a 1.5 inch (3.8 cm) length section.
- Inspect rope or cable and replace if damaged.
- Inspect mounting hardware for correct tightness and torque if necessary.
- Gears, ratchet pivot point, and shaft bushings must be kept lubricated with a thin film of oil or grease.
- Verify mast brake pin and pulley move freely.

Operation

Raising the Lights:

1. The cable must be securely fastened to the winch drum.
2. Verify the cable and cable attachments are not damaged. Contact Generac Mobile to order a replacement cable if necessary.
3. Referring to the “Lift / Let Down” decal on the winch, turn handle according to the specified direction to lift. The ratchet **MUST** make a loud clicking sound while winding the cable.

Lowering the Lights:

Referring to the “Lift / Let Down” decal on the winch, turn handle according to the specified direction to lower. No clicking will be heard because the brake system is activated.

Maintenance

The following procedures should be performed at least annually:

1. The gears and bushings of the winch must be kept lubricated. Apply a thin film of grease to the gear teeth, and oil the bushings as needed.
2. The ratchet pawl pivot point must be kept lubricated with a thin oil.

NOTE: Do not get oil or grease on the brake mechanism.

Electric Winch (If Equipped): Use, Operation, and Maintenance

- Keep the winch free of dirt, oil, grease, water, and other substances.
- Check all mounting bolts and verify they are tightened to the recommended torque values. Replace any damaged fasteners.
- Periodically inspect all connections to verify they are tight and free of corrosion.
- Inspect the cable for visible damage every time the winch is operated. Examples of damage are: cuts, knots, crushed or frayed portions, and broken strands. Replace cable immediately if damaged. Failure to replace a damaged cable could result in breakage.
- Regularly inspect the brake for slippage or drift. This is detected visually when winch is under load. If winch drum continues to turn after controls are released, the brake may need to be replaced.
- Periodically clean and grease the brake assembly. This will ensure correct performance and extend the life of the winch. If winch seems to labor or get excessively hot during the lowering of loads, the brake will need to be serviced or replaced.
- Inspect motor brushes periodically and replace when necessary.

NOTE: Only the motor brushes and brake assembly require periodic replacement.

Winch Mechanical Brake

The mechanical brake generates heat when loads are lowered and the wire cable is powered out. Avoid overheating the mechanical brake. Overheating the mechanical brake may result in permanent damage to, or failure of, the brake. Replace any damaged brake components before resuming use of the winch.

Whine or chatter associated with a new mechanical brake is normal and typically disappears with use.

Overheating the mechanical brake may result in permanent damage to, or failure of, the brake. Replace any damaged brake components before resuming use of the winch.

Trailer Wheel Bearings

The trailer axles are equipped with a Zerk grease fitting to allow lubrication of the wheel bearings without the need to disassemble the axle hub. Use only a high quality grease made specifically for lubrication of wheel bearings, such as Valvoline W615 or equivalent.

See **Figure 4-1**. Proceed as follows to lubricate the wheel bearings:

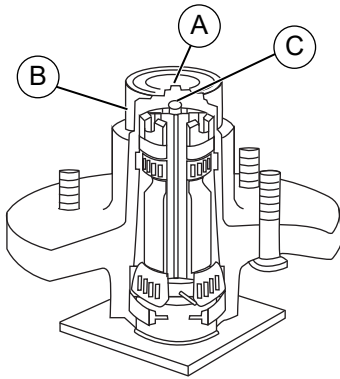

002540

Figure 4-1. Wheel Bearing Cross Section

1. Remove the small rubber plug (A) from the metal end cap (B).
2. Attach a standard grease gun fitting to the Zerk grease fitting (C).

3. Pump grease into the Zerk fitting until fresh grease is visible around the nozzle of the grease gun.
4. Wipe any excess grease from the axle hub with a clean cloth and replace the rubber plug.

The minimum recommended lubrication is every 12 months or 12,000 miles (19,312 km). More frequent lubrication may be required under extremely dusty or damp operating conditions.

Every six months, or depending on usage, check for play in each bearing by jacking up the trailer, then trying to rock the wheel. If further assistance is required, contact Generac Mobile Technical Service at 1-800-926-9768.

Jack Maintenance

Before each use, inspect each jack foot for damage and remove any mud or debris. The jacks must be clean and in good operating condition to correctly support the unit.

Winch Maintenance Schedule

Maintenance Activity	After First Operation	Before Each Use	Semi-Annually
Inspect fasteners	◆		◆
Inspect electrical connections	◆		◆
Clean and grease brake assembly			◆
Inspect motor brushes			◆
Inspect winch and control	◆	◆	◆

Section 5: Troubleshooting

General Troubleshooting



WARNING

Risk of burns. Allow engine to cool before draining oil or coolant. Failure to do so could result in death or serious injury.

(000139)

Some of the more common problems are listed in the table below. This information is intended to be a check or verification that simple causes can be located and fixed. It does not cover all types of problems. Refer to the OEM engine operator's manual for additional troubleshooting information. Procedures that require in-depth knowledge or skills should be referred to a GMASD.

General Troubleshooting Guide

Problem	Possible Cause	Solution
Low oil pressure shutdown	Low oil level	Verify oil level on dipstick. Add oil, if needed.
	Oil leaking from engine	Inspect the engine for leaks.
	Oil pressure switch failure	Refer to OEM engine operator's manual to identify corrective action.
High coolant temperature shutdown	Low coolant level	Add coolant if needed. Allow engine to cool, then check coolant level in radiator. Restart engine and check coolant temperature. Stop engine immediately if coolant temperature is 210 °F (99 °C) or more.
	Blockage in radiator	Inspect radiator shroud and ducting for blockage and remove any foreign matter.
	Leakage in coolant hoses, engine block, or water pump	Inspect for visible leaks. Verify tension of water pump serpentine drive belt. Remove load on generator and restart engine. Verify coolant temperature and shut engine down immediately if it starts to overheat. Refer to the OEM engine operator's manual for additional information on engine overheating.
	Faulty thermostat	Contact a GMASD to replace.
	Water pump failure	Contact a GMASD to replace.
	Incorrect mix/frozen radiator	Thaw the radiator with an external heat source and flush the coolant system with the correct coolant mixture.
Unit cranks but does not start	Low fuel level	Check fuel level in tank. Verify fuel pump operation.
	Restricted air filter	Inspect air filter for blockage. Refer to OEM engine operator's manual for additional information.
	PAS engaged	Verify PAS is off.

If problems persist, contact Generac Mobile at 1-800-926-9768 for assistance.

Troubleshooting the Lights

Only a qualified electrician should troubleshoot or repair electrical problems occurring in this equipment. Contact Generac Mobile Technical Service at 1-800-926-9768 for assistance if you have any questions, or if problems persist.



WARNING

Electrocution. Potentially lethal voltages are generated by this equipment. Render the equipment safe before attempting repairs or maintenance. Failure to do so could result in death or serious injury.

(000187)

Lights Troubleshooting Guide

Problem	Possible Cause	Solution
Mast lights off, checking outside control box	Light fixture is too hot	Allow light to cool 10–15 minutes before restarting.
	Loose lighting connections	Inspect the connections inside the mast junction box and each mast light housing/socket.
	Damaged or loose electrical cord	Inspect the mast electrical cord for damage and check the cord connections inside the control box.
	Faulty fuel filter	With engine running and lights off, measure voltage and frequency at the GFCI receptacle. Voltage should indicate 120VAC \pm 5%, and frequency should indicate 60.7 Hz \pm 5%. If frequency and voltage are both low (<114VAC, <58 Hz), replace the fuel filter.
Mast lights off, checking inside control box	Faulty generator capacitor	Measure the capacitance of the generator capacitor. If measurement is outside rating (as indicated on the capacitor), replace the capacitor.
	Loose lighting connections	Inspect the connections inside the control box.
	Generator output incorrect	Check the incoming voltage to the ballast driver by checking the available voltage on the GFCI receptacle. Incoming voltage should be 120V \pm 5V. If voltage is incorrect, the generator may require service.

Troubleshooting Controller Fault Indicators

See [Figure 5-1](#). When a fault occurs, the engine shuts off and an LED indicator illuminates on the controller.

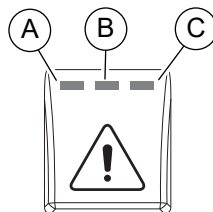

010580

Figure 5-1. Fault Indicator Button

Illuminated LED	Indicates Fault	Resolution
A	Low engine oil pressure or high engine coolant temperature	See General Troubleshooting —low oil pressure & high engine coolant temperature.
A+C	Engine overspeed or engine underspeed	<ol style="list-style-type: none"> 1. Check connection on W terminal of DC Charge Alternator (MLTS)—WH/VI to pin-9 or Engine ECU (MLTS-K) on the Power Zone controller. 2. Inspect function of DC charge alternator. 3. Inspect tension of DC charge alternator drive belt. 4. Contact Generac Mobile.
C	Fail to crank (AUTO mode only)	See General Troubleshooting —fail to crank
B+C	Loss of speed signal	<ol style="list-style-type: none"> 1. Check connection on W terminal of DC Charge Alternator (MLTS)—WH/VI to pin-9 or Engine ECU (MLTS-K) on the Power Zone controller. 2. Inspect function of DC charge alternator. 3. Inspect tension of DC charge alternator drive belt. 4. Contact Generac Mobile.

IMPORTANT NOTE: To clear controller faults, press and hold the Fault Indicator button ([Figure 5-1](#)) for three seconds.

THIS PAGE INTENTIONALLY LEFT BLANK

Section 6: Wiring Diagrams

Mast Junction Box Wiring and Light Connections

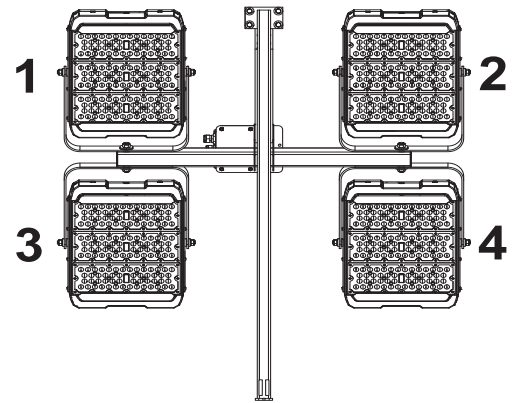
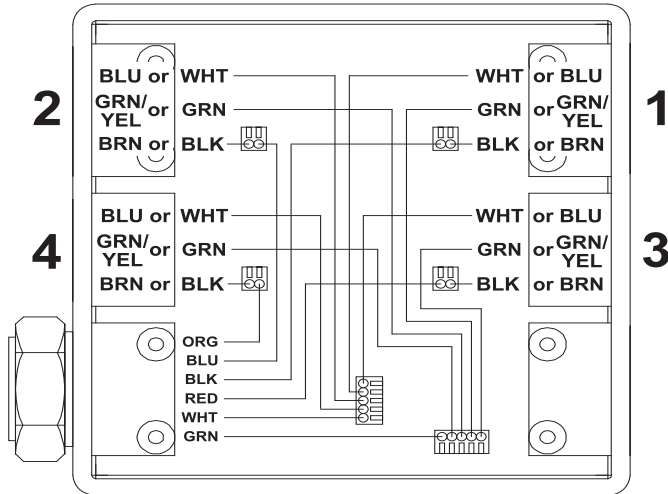

010606

MLTS-K Analog (No-Export Power) (1 of 3)

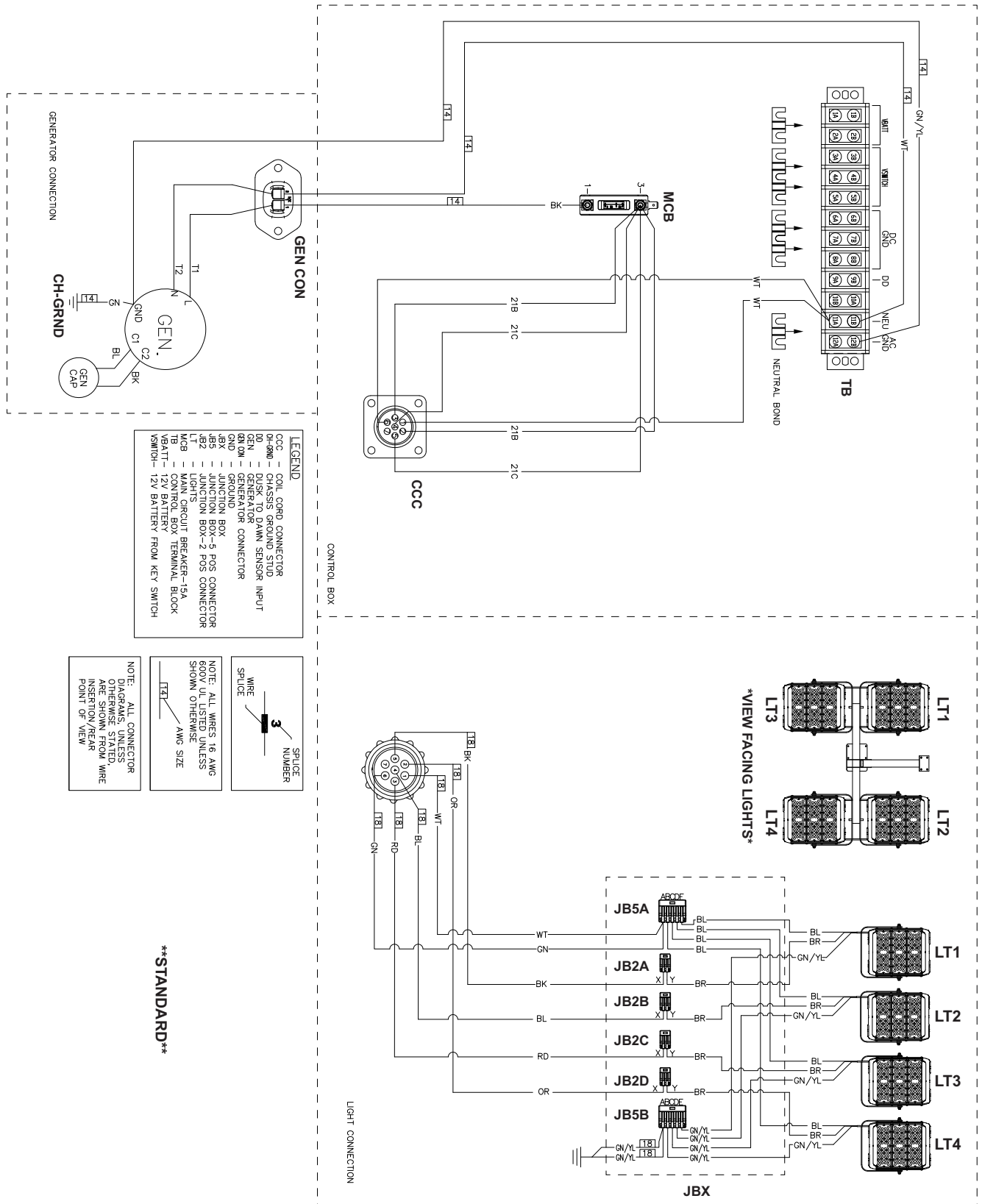

A0004106725_C_11/18/2023

MLTS-K Analog (Export Power) (2 of 3)

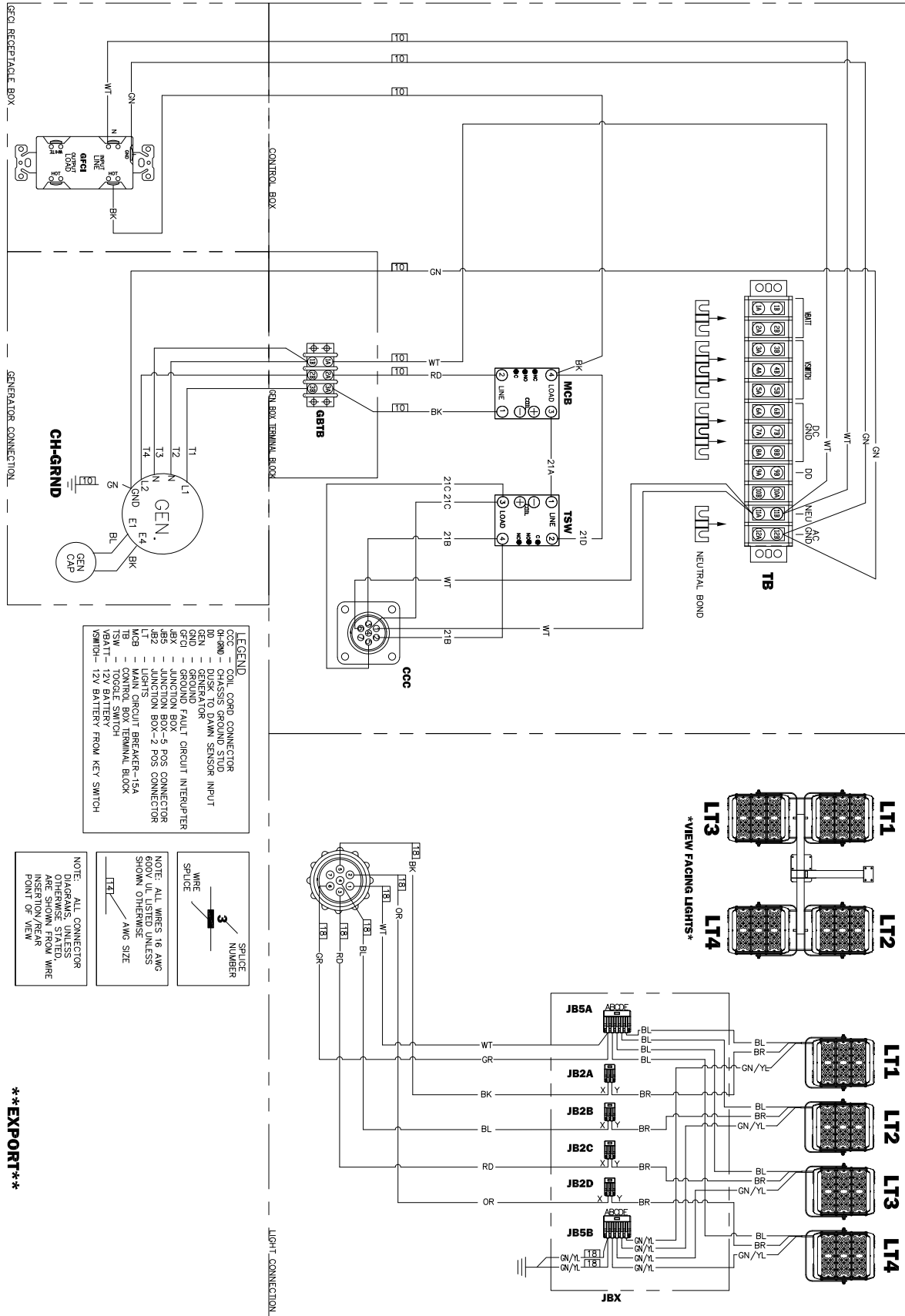

A0004106725_C

MLTS-K Analog (Export w/Input Power) 3 of 3

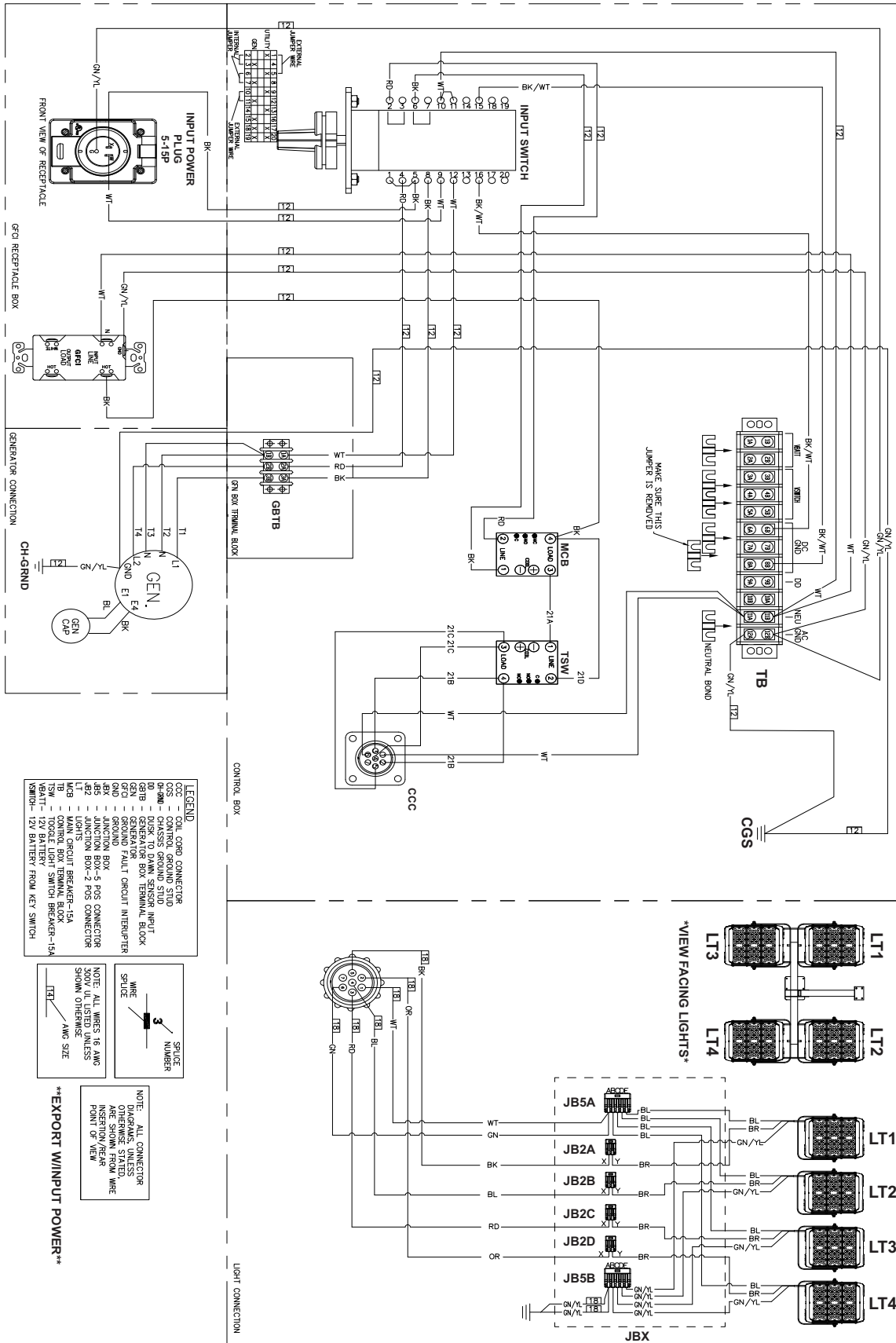

A0004106725_C_11/18/2023

MLTS-K Digital (No Export) 1 of 3

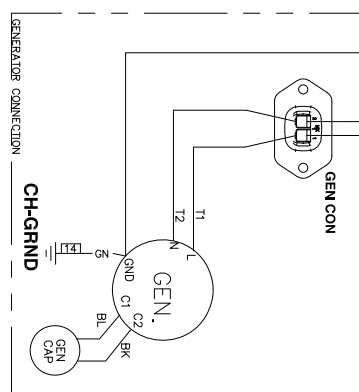
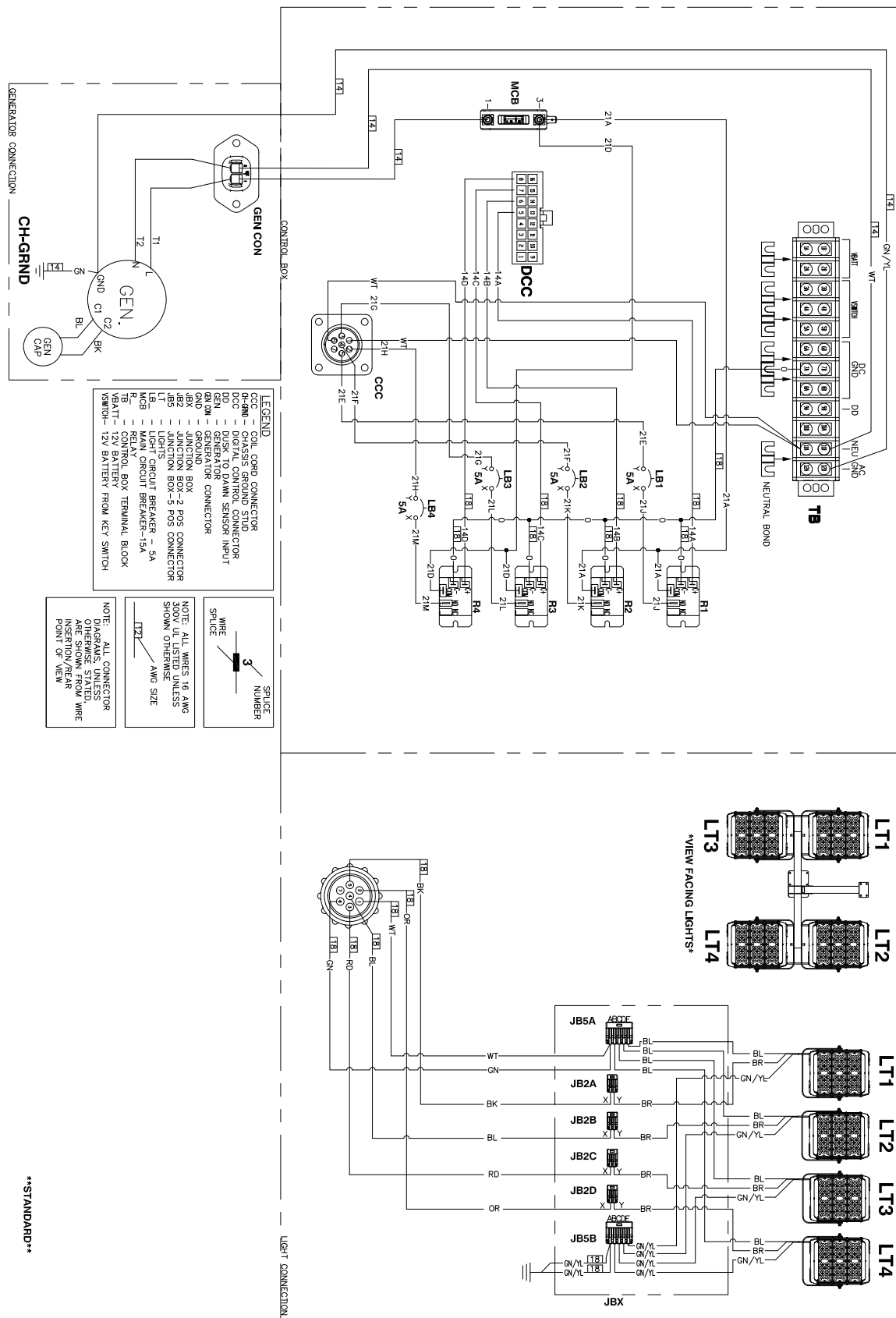

LEGEND

- CCC - COIL, COORD CONNECTOR
- DH-8MM - CHASSIS GROUND STUD
- DCC - DIGITAL CONTROL CONNECTOR
- GEN - GENERATOR
- GEN IN - GENERATOR INPUT
- GEN OUT - GENERATOR OUTPUT
- GND - GROUND
- GEN CON - GENERATOR CONNECTOR
- GEN BOX - GENERATOR BOX
- JB2 - JUNCTION BOX - 2 POS CONNECTOR
- JB5 - JUNCTION BOX - 5 POS CONNECTOR
- LB - LIGHTS CIRCUIT BREAKER - 5A
- MCB - MAIN CIRCUIT BREAKER - 15A
- R - RELAY
- RE - RELAY BOX TERMINAL BLOCK
- WT - 12V BATTERY FROM KEY SWITCH

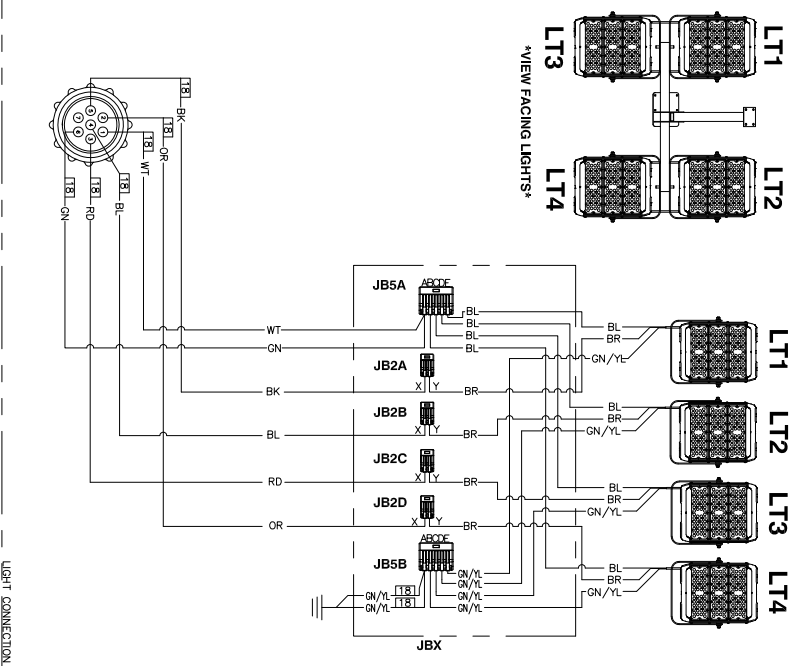
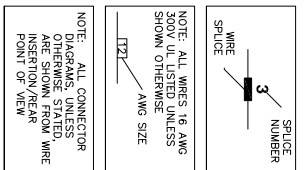

STANDARD

A0004106769_REV_C

MLTS-K Digital (Export Power) 2 of 3

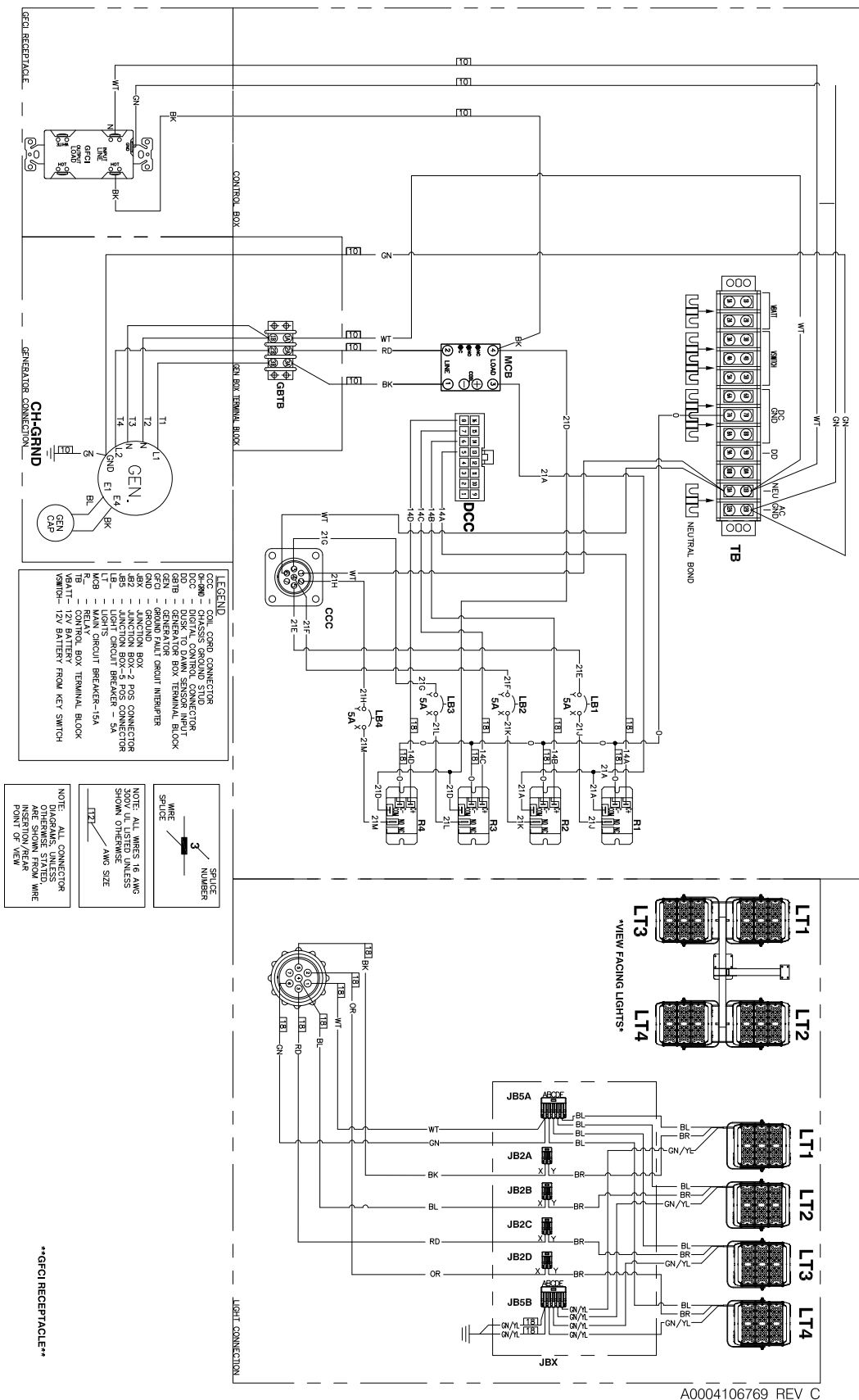

MLTS-K Digital (Export w/Input Power) 3 of 3

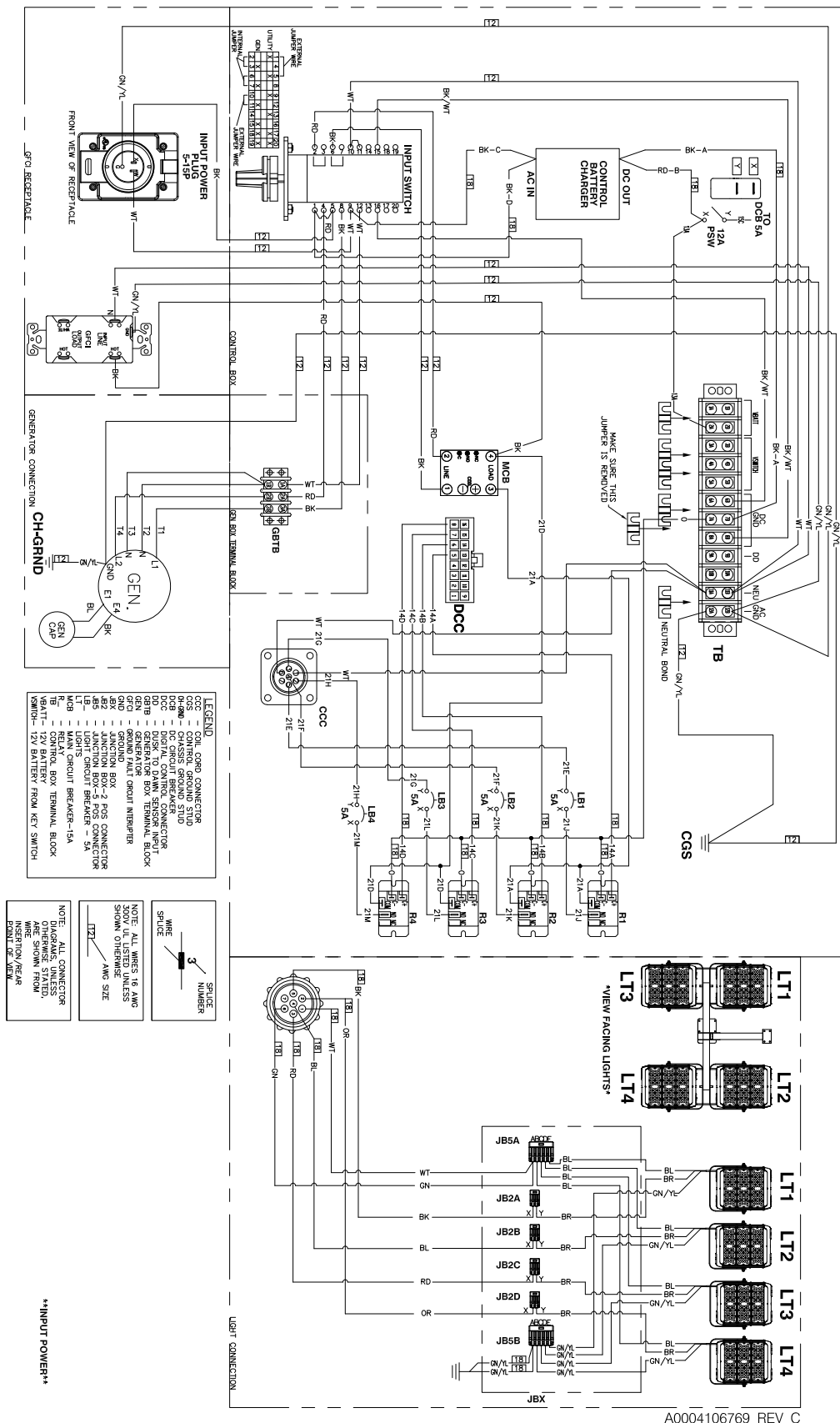

MLTS-K Analog DC Engine

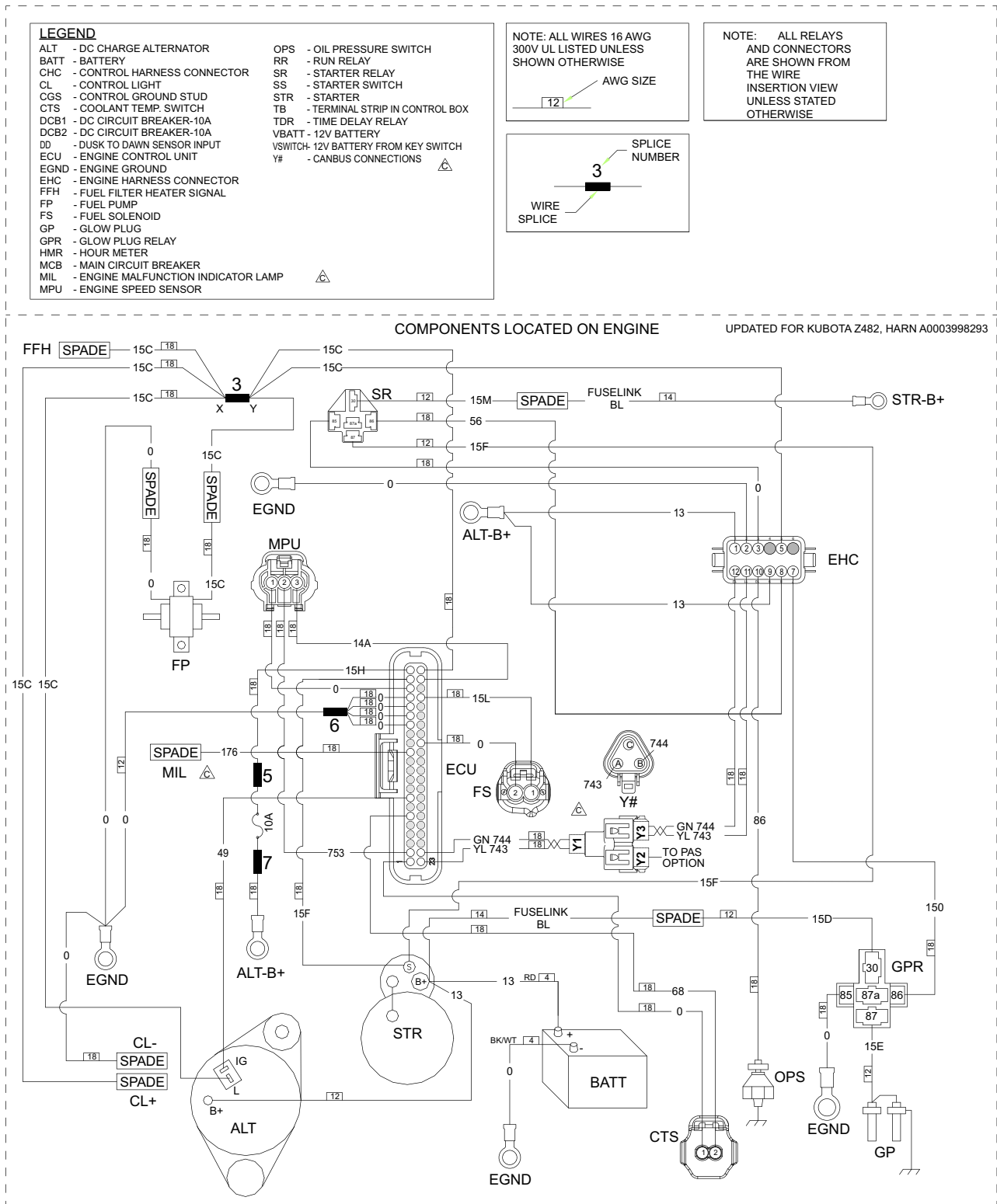

A0004106732_Rev C

MLTS-K Analog Control Box

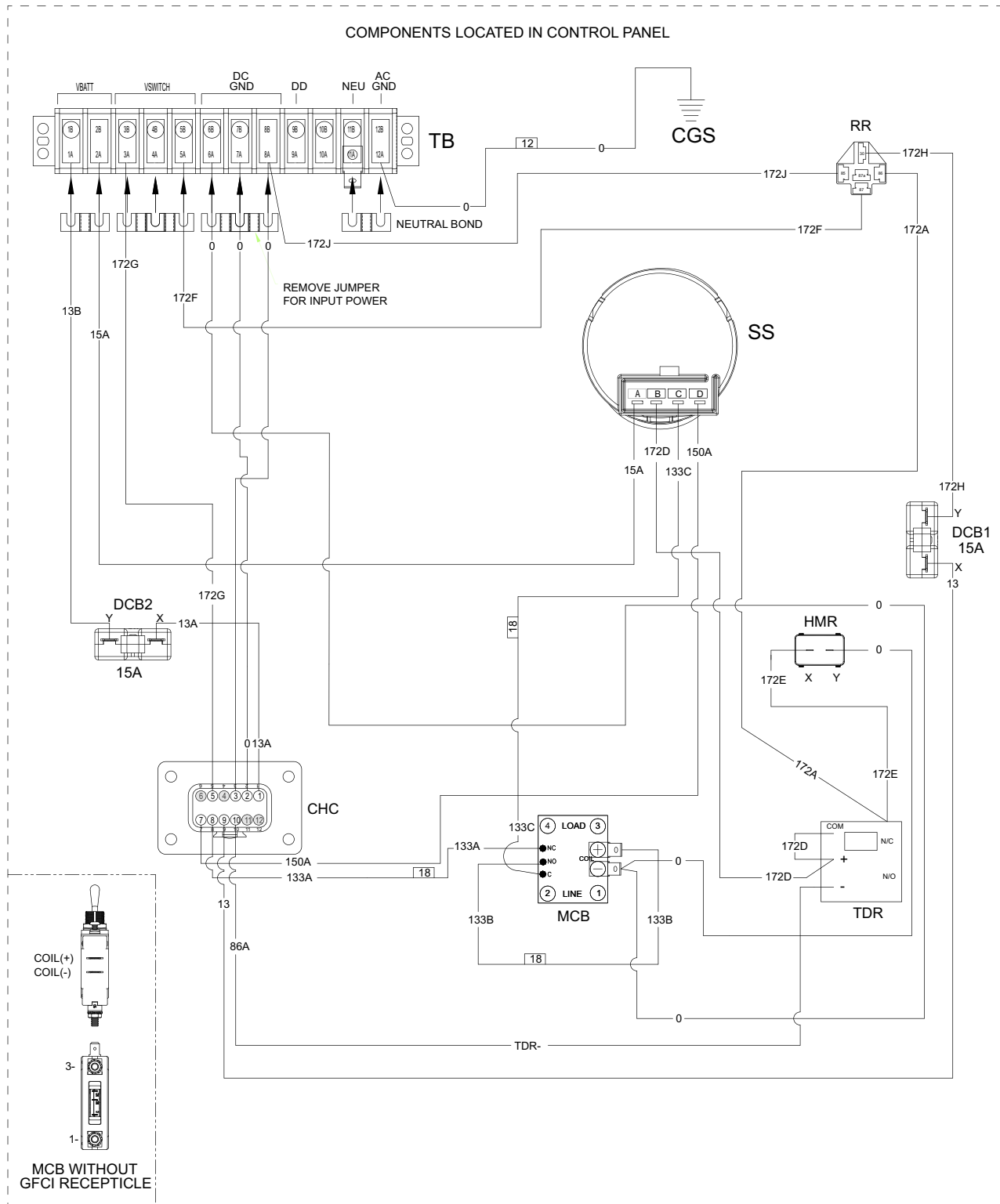

A0004106732_Rev C

MLTS-K Digital Control Box

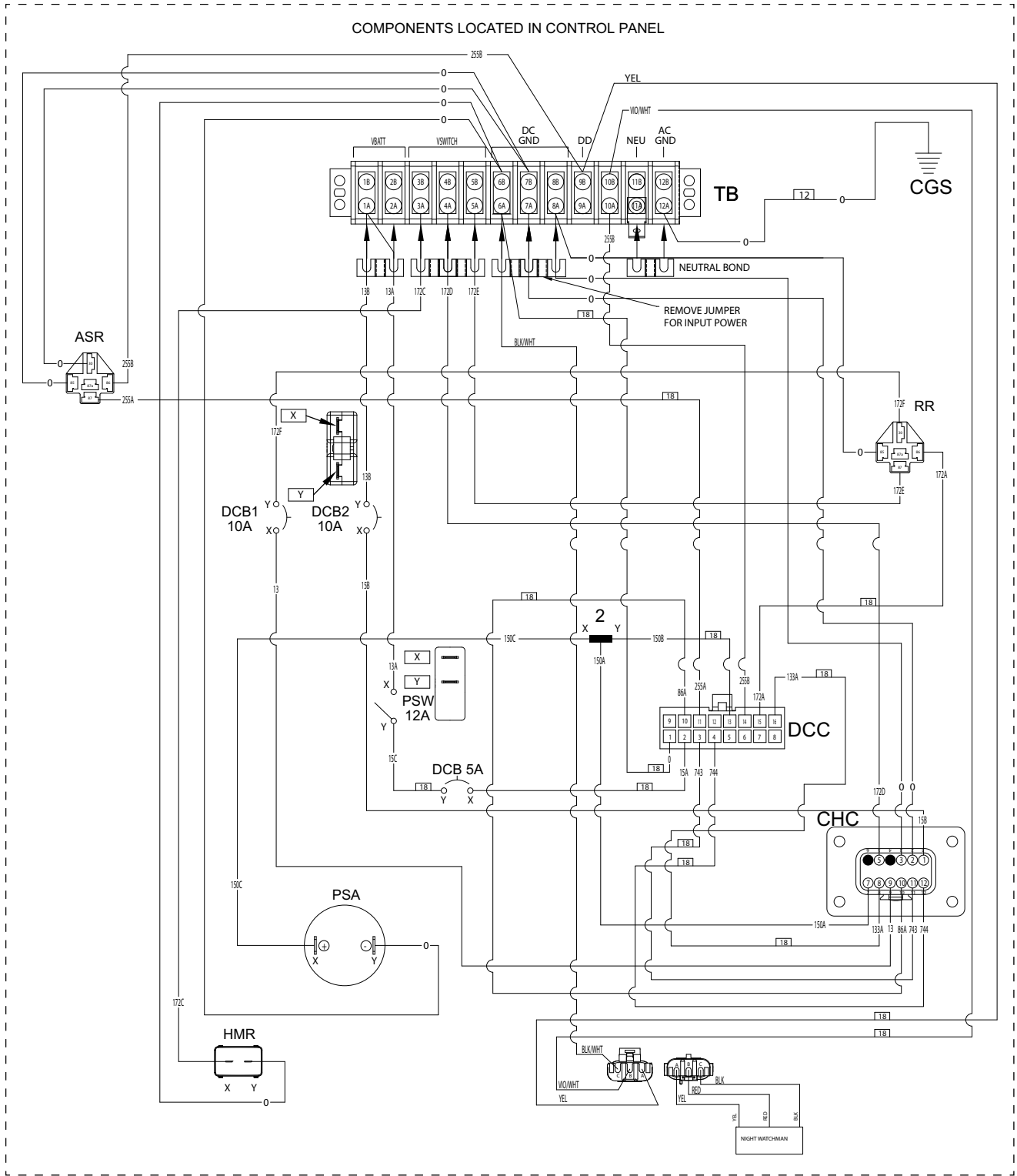

A0004106765_REV_A

MLTS Winch and Heated Fuel Filter (if equipped)

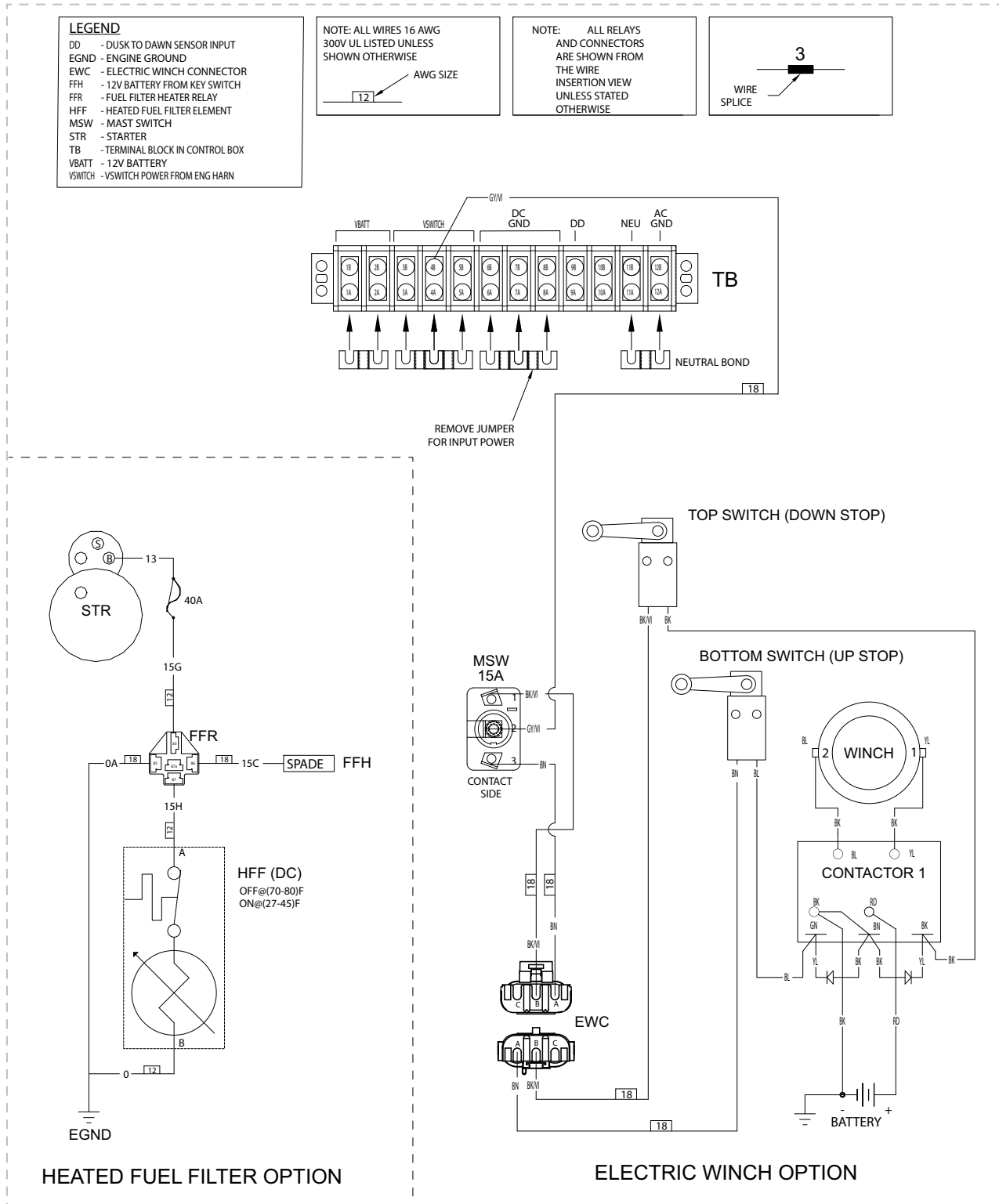

A0004106732_Rev C

MLTS-K Positive Air Shutdown (if Equipped)

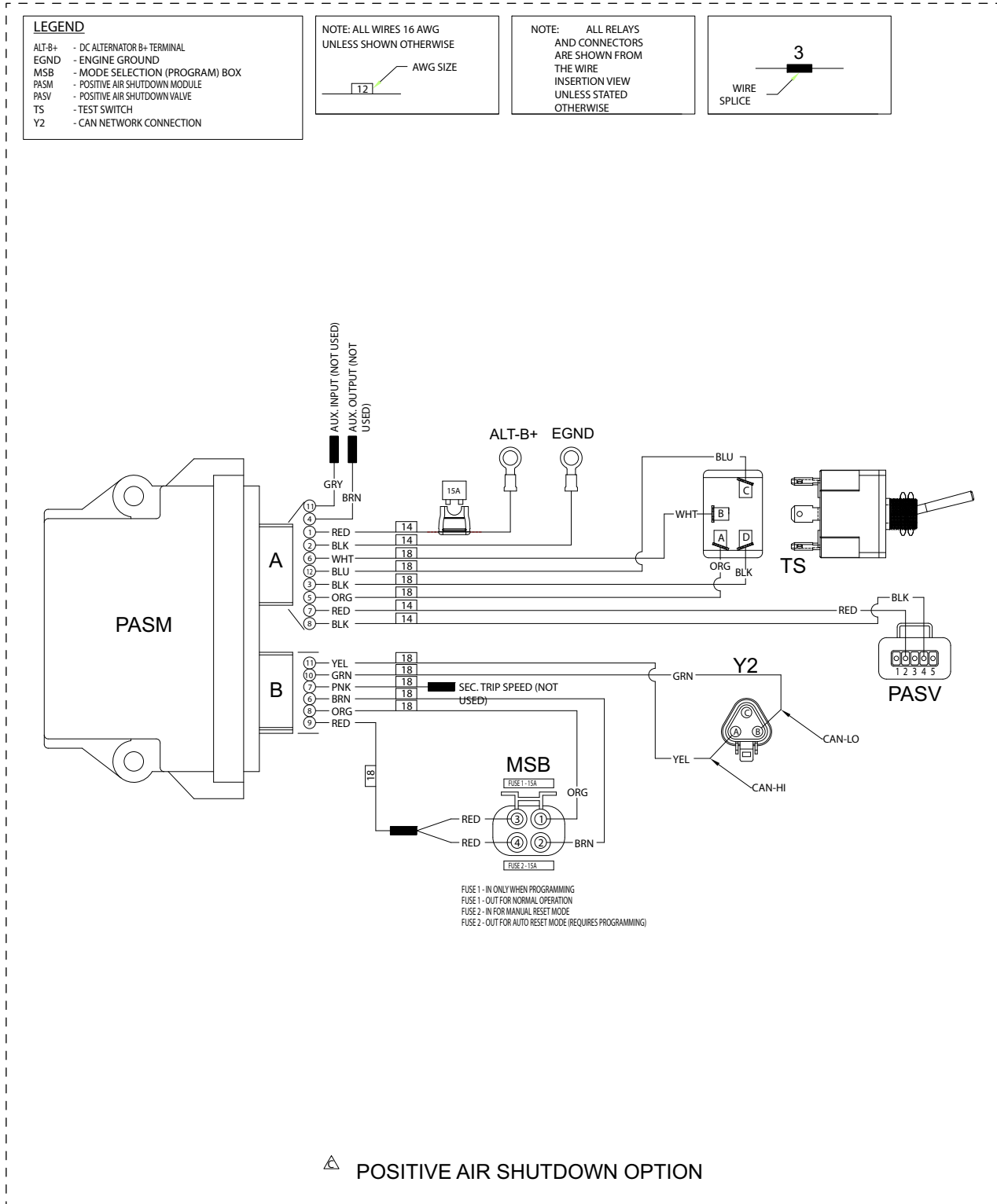

A0004106732_Rev C

MLTS-M Positive Air Shutdown (If Equipped)

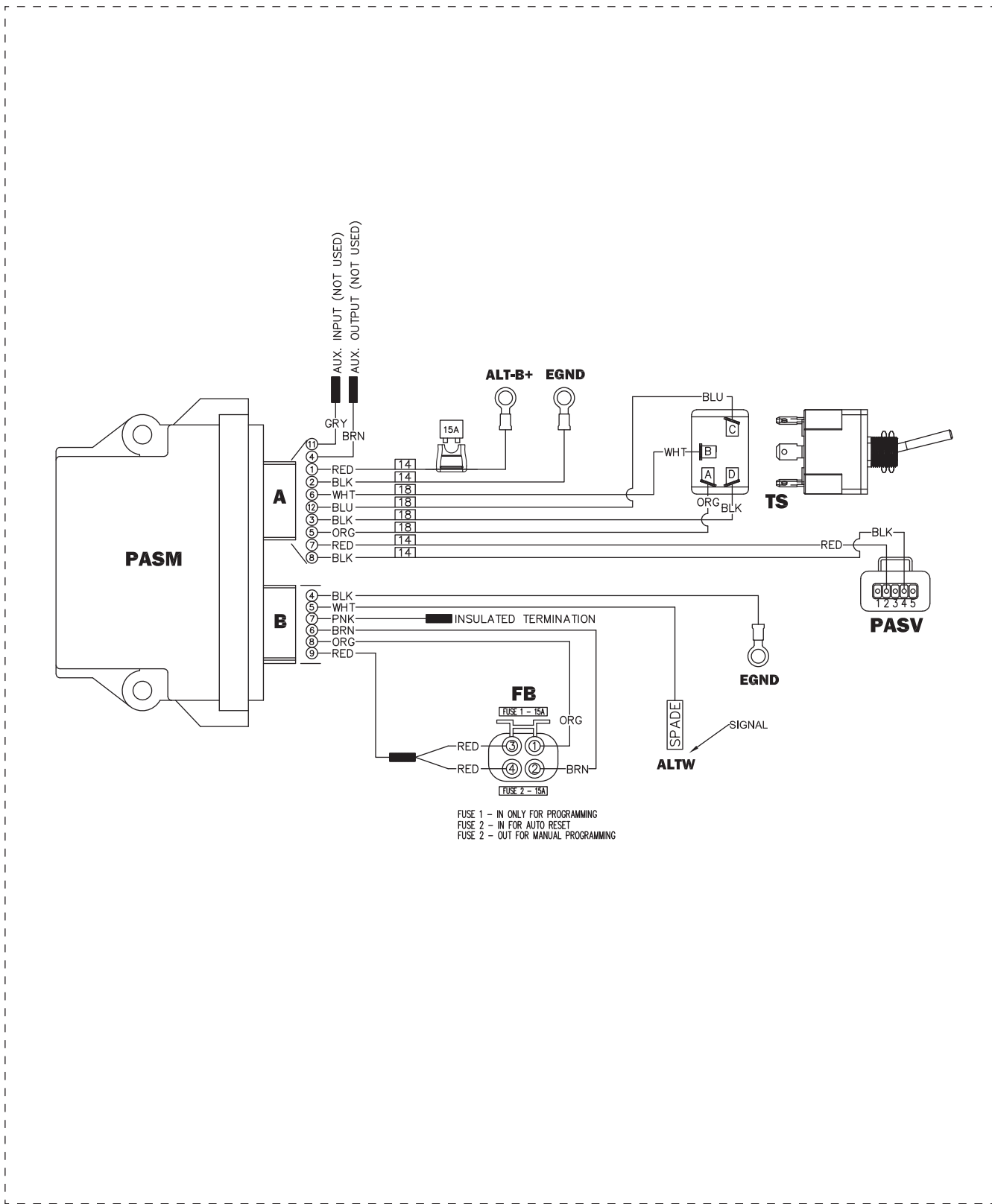

MLTS- V2-M

A0005424017 Rev. A

MLTS ZTR Telemetry (if equipped)

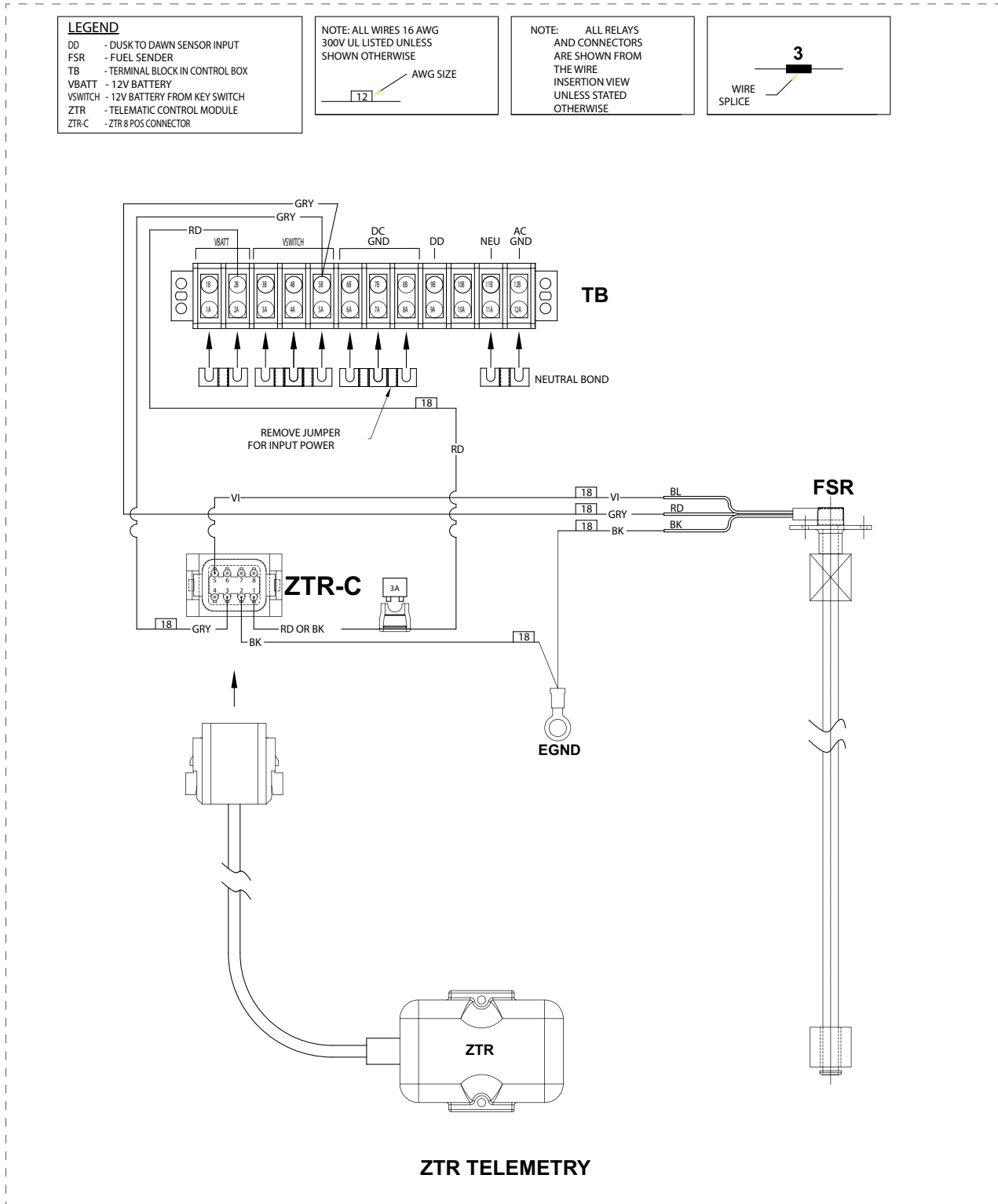

A0004106732_Rev C

MLTS-K Morey Telemetry (if equipped)

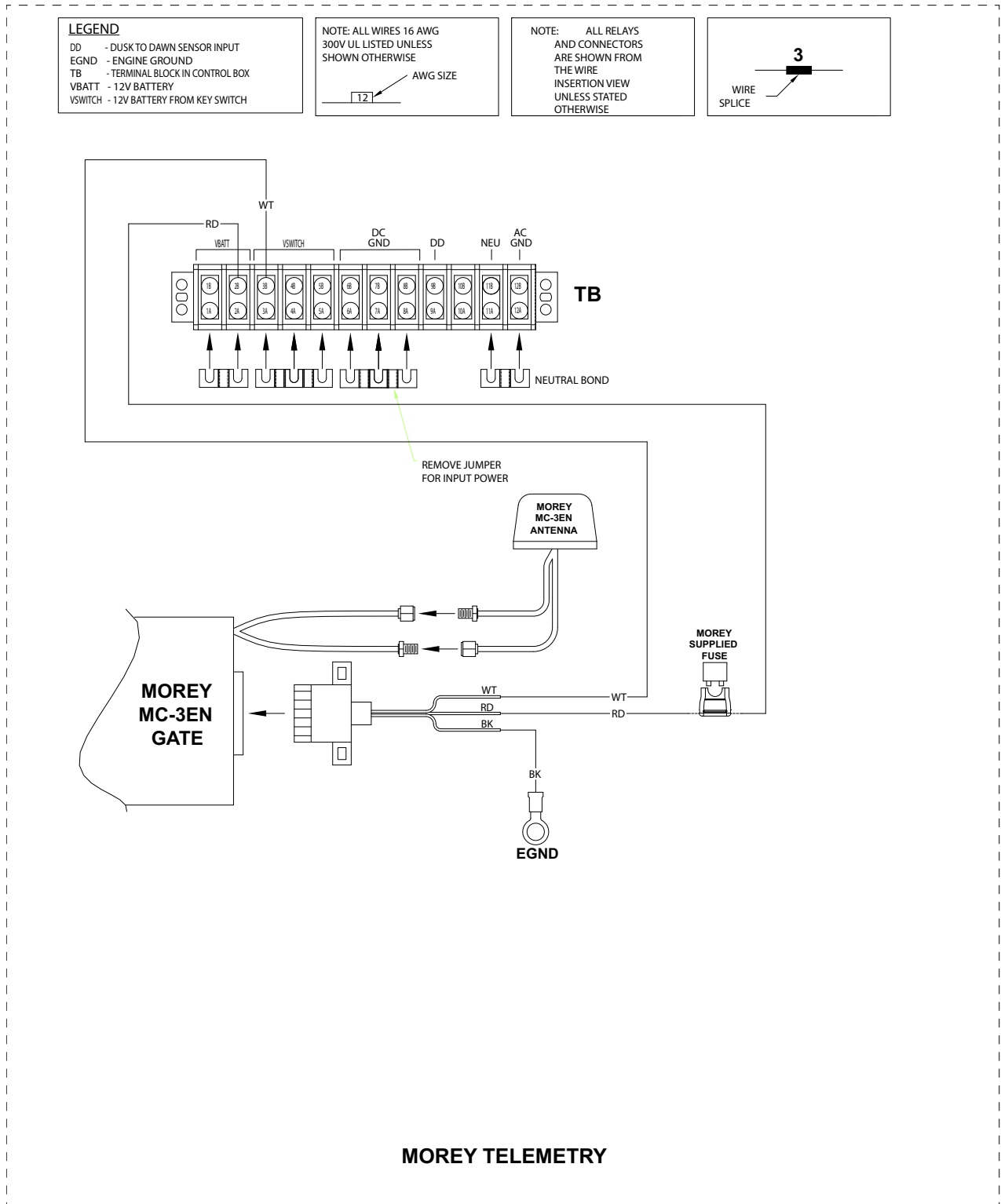

A0004106732_Rev C

MLTS-M/K Track Unit Telemetry (If Equipped)

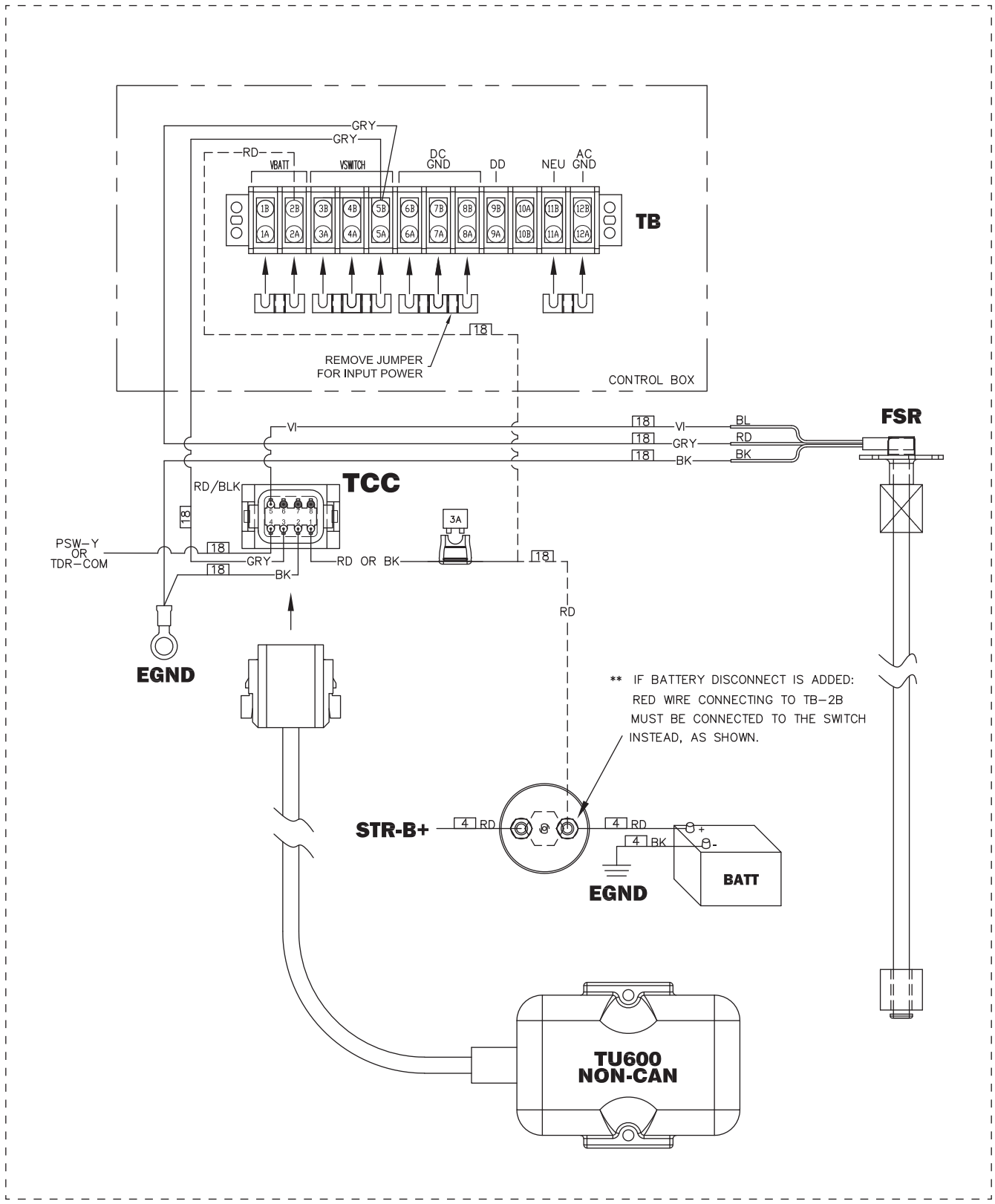

MLTS- V2-MK

A0005423981 Rev. A

MLTS-M AC Wiring (No Export Power) 1 of 3

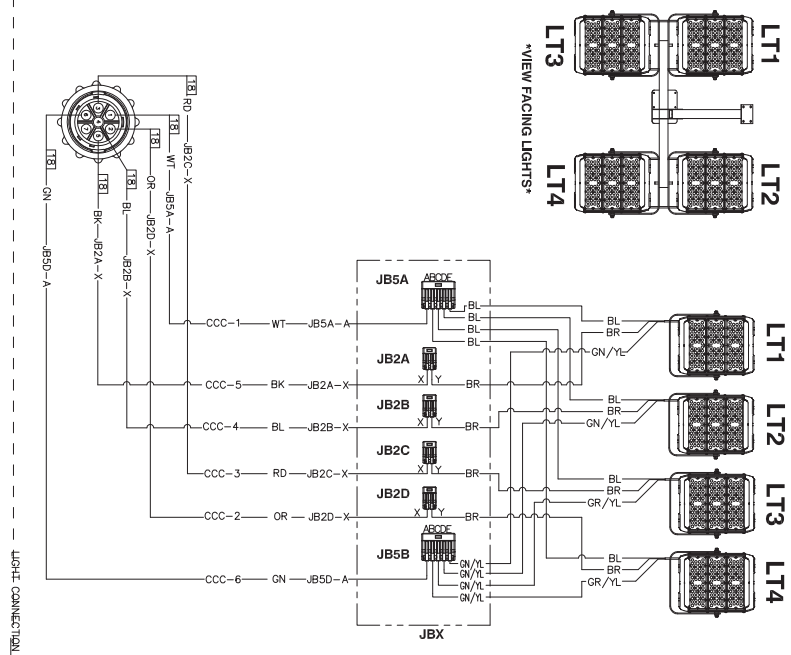
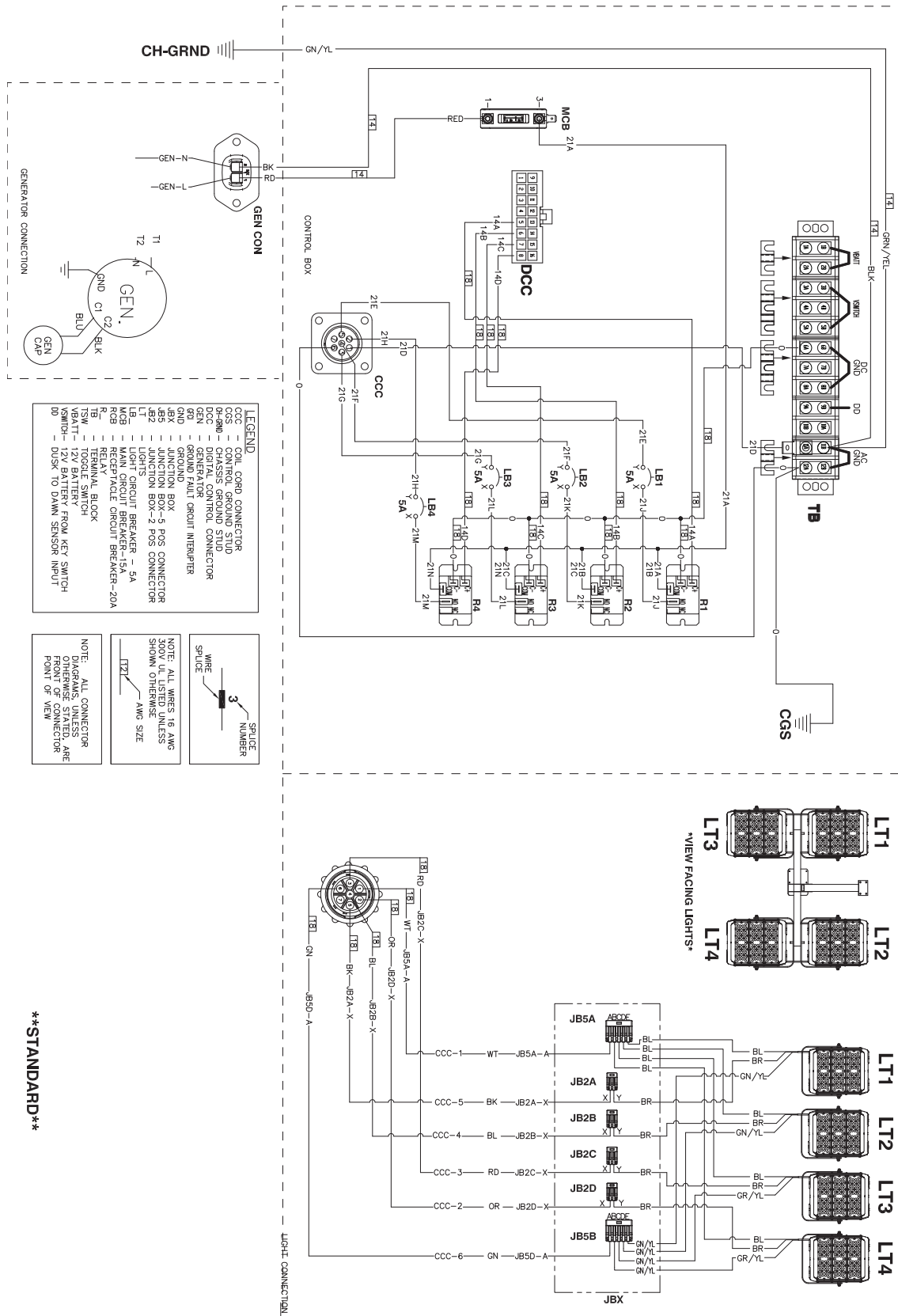

A000221210SH1_B_11.05.19

MLTS-M AC Wiring (Export Power) 2 of 3

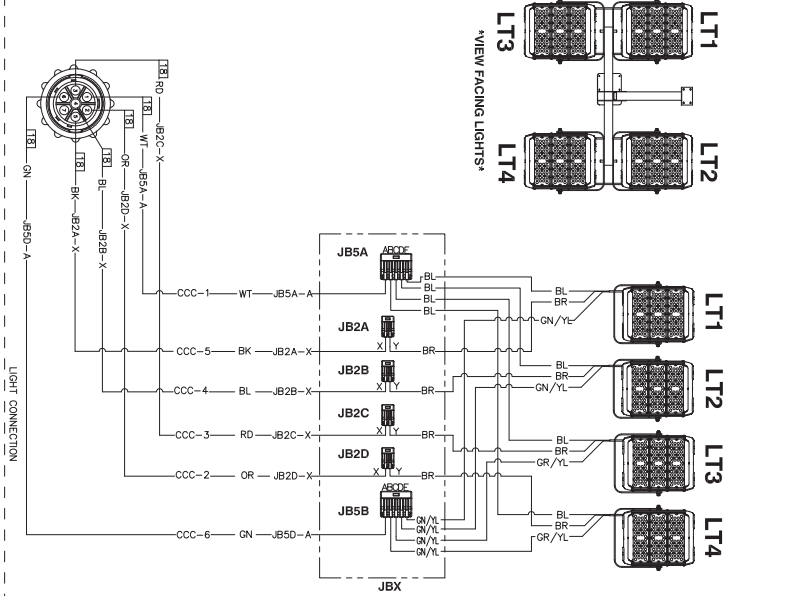
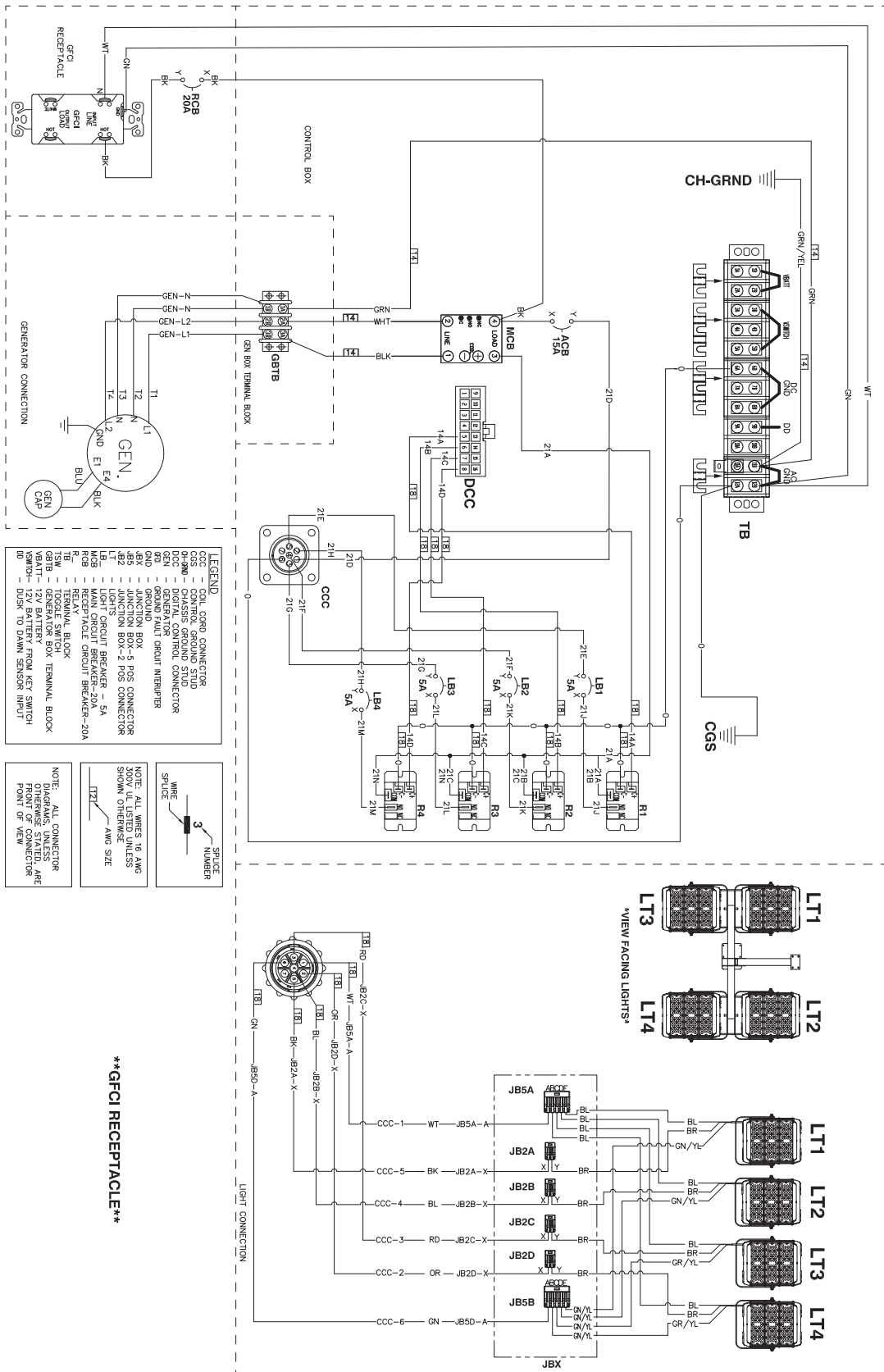

A0000221210SH2_B_11.05.19

MLTS-M AC Wiring - Digital (240 VAC Input Power) 3 of 3

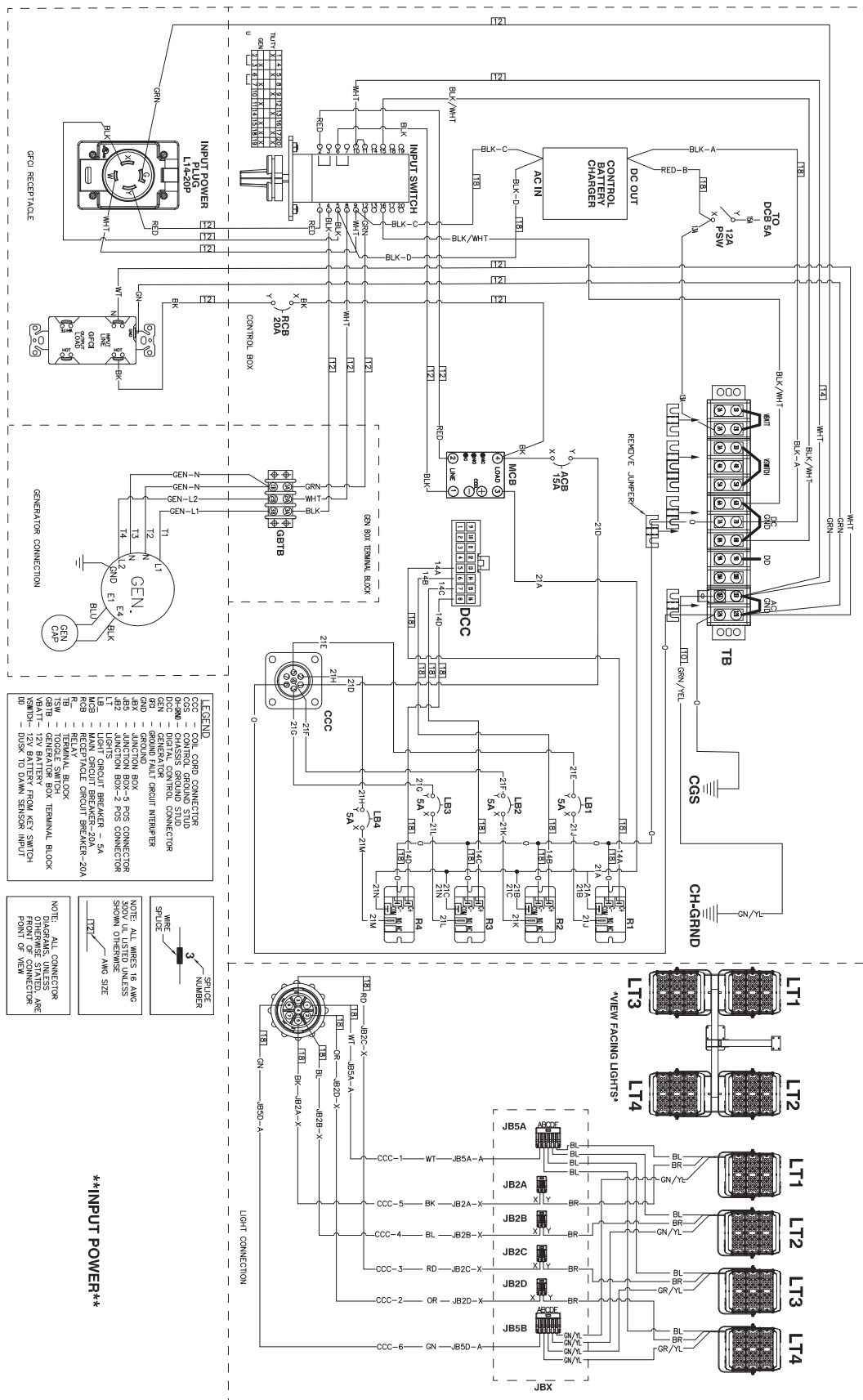

A0000221210SH3_B_11.05.19

MLTS-M AC Wiring - Digital (120 Shore Power If Equipped)

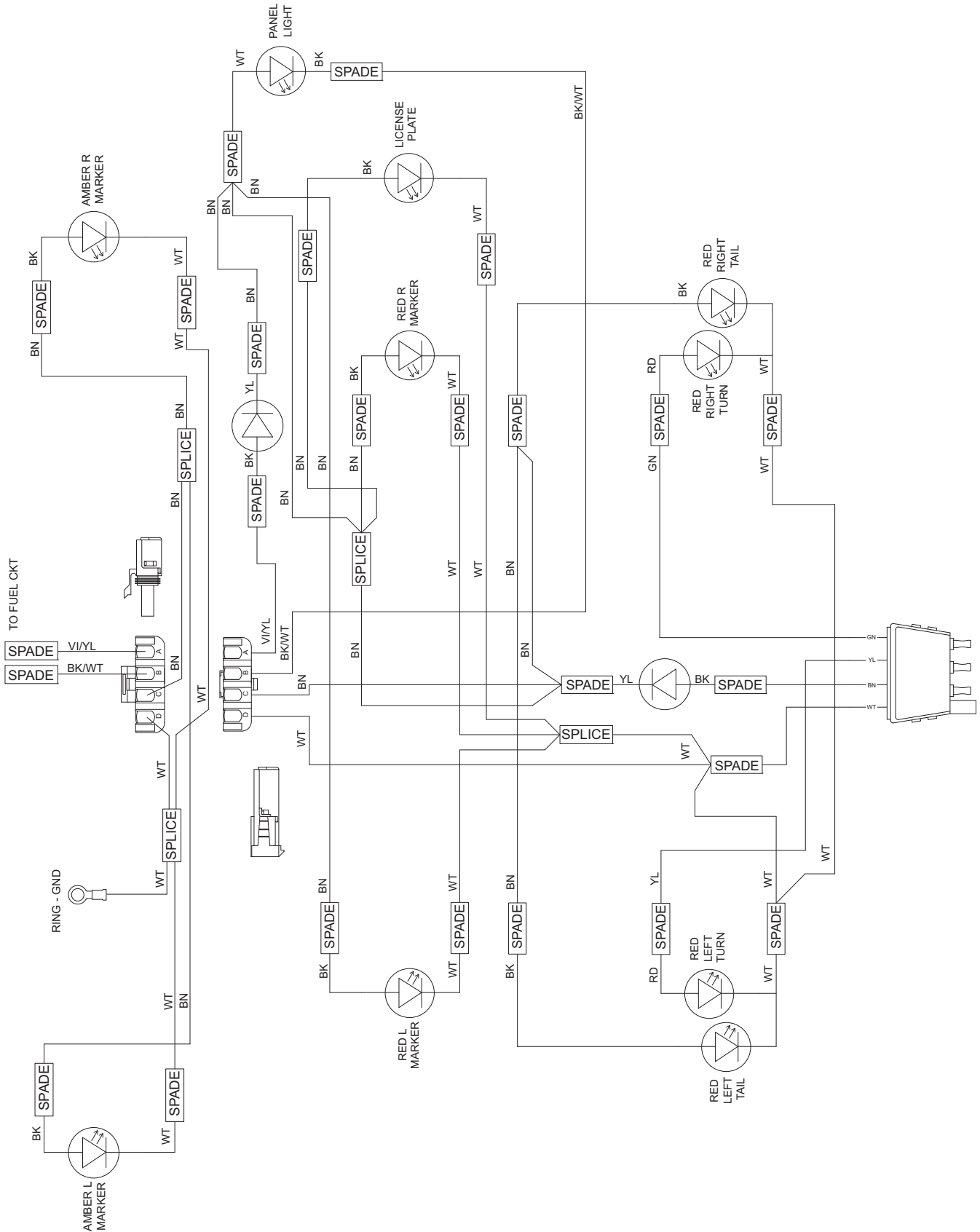

90520_D_08.27.14

MLTS-M DC Wiring - Digital (If Equipped)

LEGEND

ALT - DC CHARGE ALTERNATOR	GFCI - GROUND FAULT CIRCUIT INTERRUPTER	R_ - RELAY#
ALT-B+- DC ALTERNATOR B+ TERMINAL	GND - GROUND	RBL - RIGHT BRAKE LIGHT
ALTW - DC ALTERNATOR SPEED SIG FOR PAS	GP_ - GLOW PLUG#	RCB - RECEPTACLE CIRCUIT BREAKER-20A
ASR - AUTO START RELAY	GPR - GLOW PLUG RELAY	RR - RUN RELAY
BATT - BATTERY	HFF - HEATED FUEL FILTER ELEMENT	RSF - RIGHT SIDE FORWARD LIGHT
CCC - COIL CORD CONNECTOR	HRM - HOUR METER	RSR - RIGHT SIDE REARWARD LIGHT
CHC - CONTROL HARNESS CONNECTOR	IPP - INPUT POWER PLUG	SS - STARTER SWITCH
FRAME - CHASSIS GROUND STUD	IPS - INPUT POWER SWITCH	SR - START RELAY
CL_ - CONTROL LIGHT#	JBX - JUNCTION BOX	STR - STARTER
CGS - CONTROL GROUND STUD	JB2 - JUNCTION BOX-2 POS CONNECTOR	TB - TERMINAL BLOCK IN CONTROL BOX
CTS - COOLANT TEMP. SWITCH	JB5 - JUNCTION BOX-5 POS CONNECTOR	TC - TRAILER CONNECTOR
DCB_ - DC CIRCUIT BREAKER#	LB_ - LIGHT CIRCUIT BREAKER#	TCC - TELEMETRY CONNECTOR (TU)
DCC - DIGITAL CONTROL CONNECTOR	LBL - LEFT BRAKE LIGHT	TDR - TIME DELAY RELAY
DD - DUSK TO DAWN SENSOR INPUT	LPL - LICENSE PLATE LIGHT	TS - TEST SWITCH
EGND - ENGINE GROUND	LSF - LEFT SIDE FORWARD LIGHT	TSW - LIGHT SWITCH BREAKER-15A
EHC - ENGINE HARNESS CONNECTOR	LSR - LEFT SIDE REARWARD LIGHT	VBATT - 12V BATTERY
EWC - ELECTRIC WINCH CONNECTOR	LT_ - LIGHT#	VSMITH - VSWITCH POWER FROM ENG HARN
FB - FUSE BOX	MCB - MAIN CIRCUIT BREAKER-35A	ZTR_ - TELEMETRY CONNECTOR (ZTR)
FFH - FUEL FILTER HEATER SIGNAL	MSW - MAST SWITCH	
FFR - FUEL FILTER HEATER RELAY	OPS - OIL PRESSURE SWITCH	
FP - FUEL PUMP	PASM - POSITIVE AIR SHUTDOWN MODULE	
FS - FUEL SOLENOID	PASV - POSITIVE AIR SHUTDOWN VALVE	
FSR - FUEL LEVEL SENDER	PSA - PRE-START ALARM	
GEN - GENERATOR	PSW - POWER TOGGLE SWITCH	

NOTE: ALL RELAYS AND CONNECTORS ARE SHOWN FROM THE WIRE INSERTION VIEW UNLESS STATED OTHERWISE

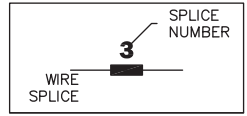

NOTE: ALL WIRES 16 AWG 300V UL LISTED UNLESS SHOWN OTHERWISE

12 AWG SIZE

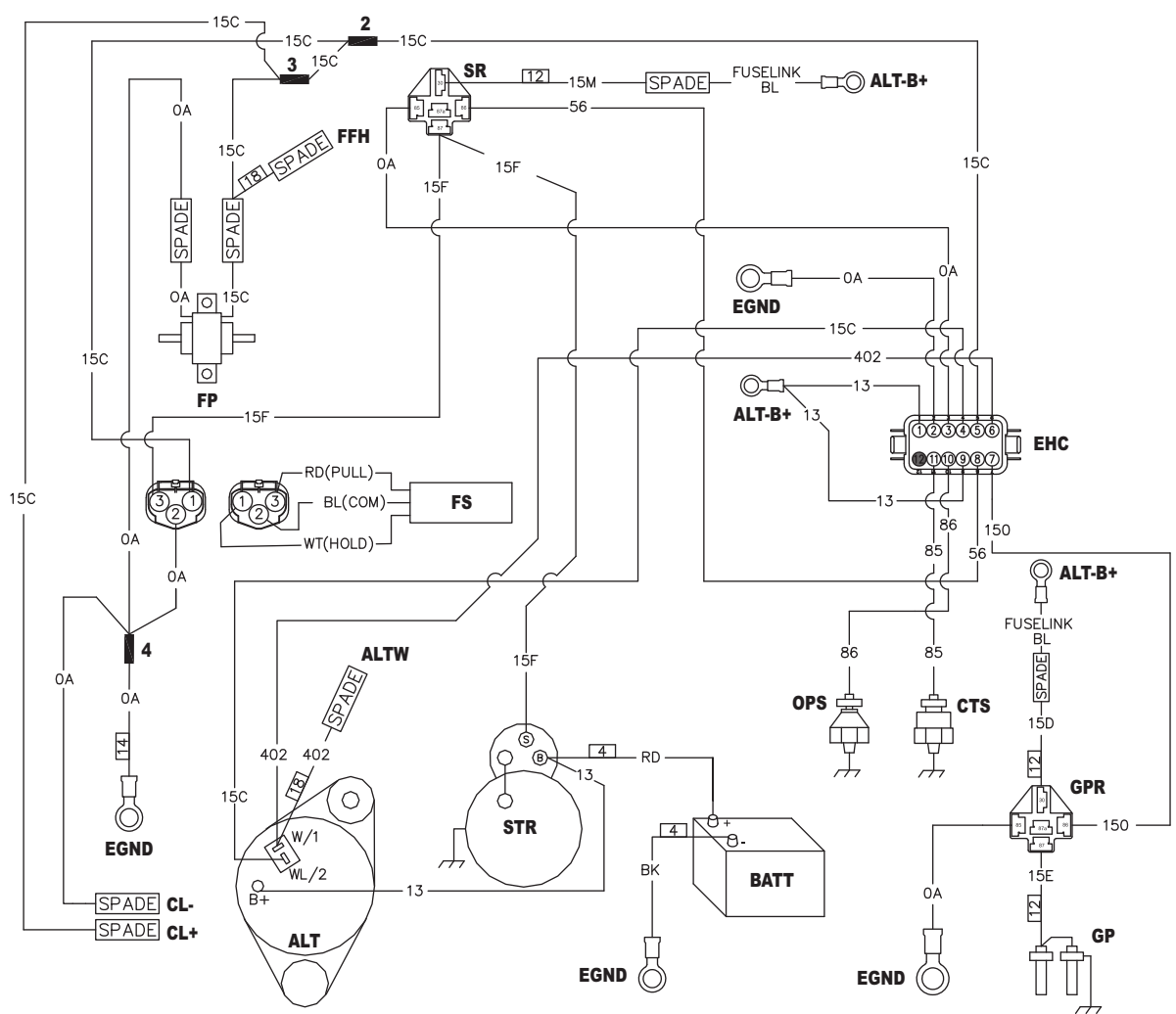

MLTS- V2-M

A0005424017 Rev. A

MLTTrailer Lights

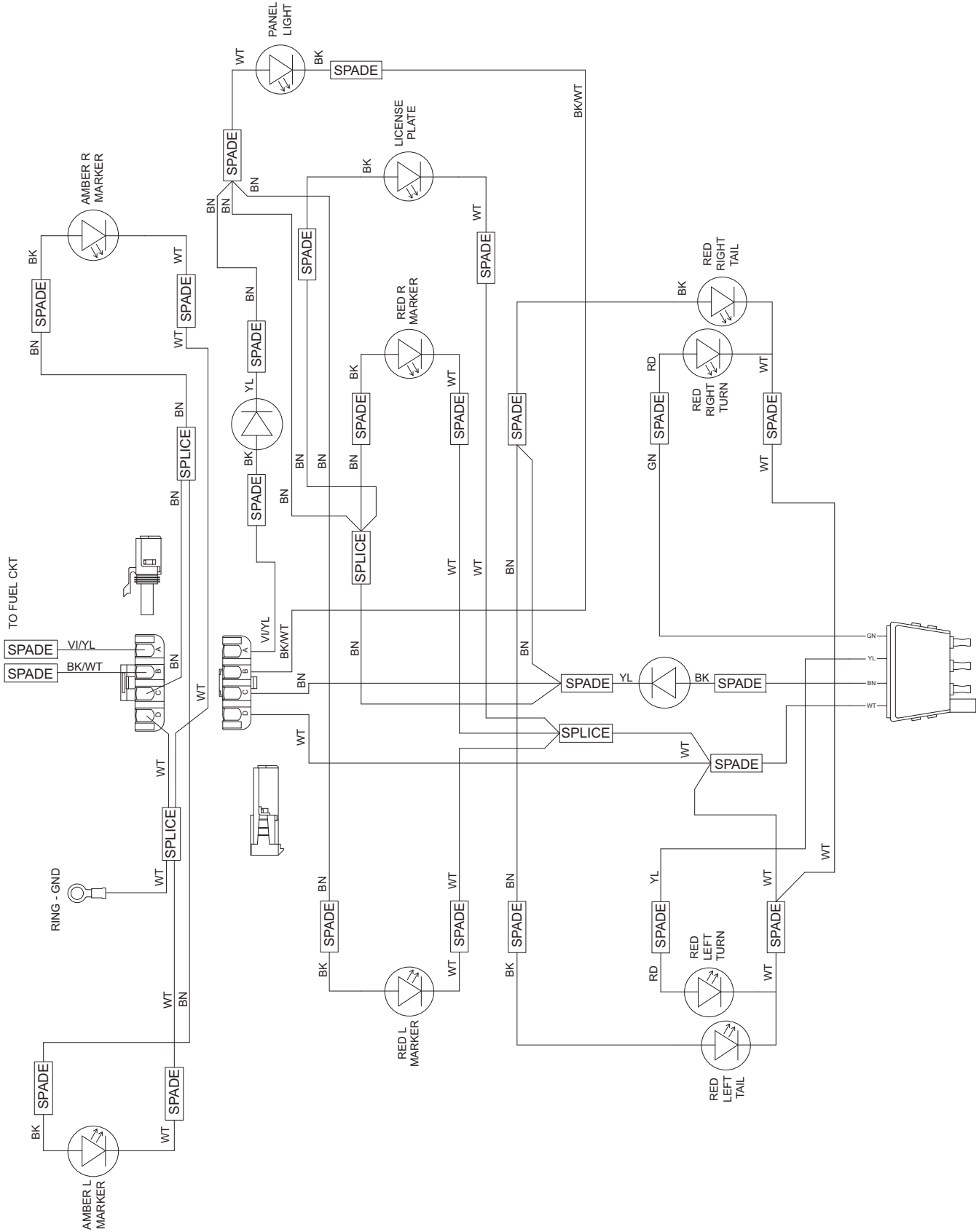

90520_D_08.27.14

Section 7: NHTSA Trailer Equipment Requirements

Reporting Safety Defects to the United States Government

If you believe your trailer has a defect which could cause a crash or could cause injury or death, you should immediately inform the National Highway Traffic Safety Administration (NHTSA) in addition to notifying Generac Mobile.

If NHTSA receives similar complaints, it may open an investigation; and if it finds that a safety defect exists in a group of vehicles, it may order a recall and remedy campaign. However, NHTSA cannot become involved in an individual problem between you, your GMASD, or Generac Mobile.

To contact NHTSA, you may either call the Auto Safety Hotline toll-free at 1-888-327-4236 (TTY: 1-800-424-9153), go to <http://www.safercar.gov>, or write to:

Administrator
NHTSA
400 Seventh Street, SW.
Washington, DC 20590

You can also obtain other information about motor vehicle safety from <http://www.safercar.gov>.

Tire Safety Information

The following section contains tire safety information as required by 49 CFR 575.6. It will cover the following:

- Tire labeling, including a description and explanation of each marking on tires provided with the vehicle, and information about the location of the Tire Identification Number (TIN);
- Recommended tire inflation pressure, including a description and explanation of:
 - Recommended cold tire inflation pressure,
 - The vehicle placard and tire inflation pressure label and their location in the vehicle
 - Adverse safety consequences of underinflations (including tire failure), and
 - Measuring and adjusting air pressure to achieve proper inflation;
- Glossary of tire terminology, including “cold tire pressure”, “maximum inflation pressure,” and “recommended inflation pressure,” and other non-technical terms;
- Tire care, including maintenance and safety practices;
- Vehicle load limits, including a description and explanation of:
 - Locating and understanding load limit information, total load capacity, seating capacity, towing capacity, and cargo capacity,

- Calculating total and cargo load capacities with varying seating configurations including quantitative examples showing/illustrating how the vehicle’s cargo and luggage capacity decreases as the combined number and size of occupants increases,
- Determining compatibility of tire and vehicle load capabilities,
- Adverse safety consequences of overloading on handling and stopping and on tires.

Steps for Determining Correct Load Limit – Trailer

Determining the load limits of a trailer includes more than understanding the load limits of the tires alone. On all trailers there is a Federal certification / VIN label that is located on the forward half of the left (road) side of the unit. This certification / VIN label will indicate the trailer’s Gross Vehicle Weight Rating (GVWR). This is the most weight the fully loaded trailer can weigh. It will also provide the Gross Axle Weight Rating (GAWR). This is the most a particular axle can weigh. If there are multiple axles, the GAWR of each axle will be provided.

If your trailer has a GVWR of 10,000 pounds or less, there is a vehicle placard located in the same location as the certification label described above. This placard provides tire and loading information. In addition, this placard will show a statement regarding maximum cargo capacity. Cargo can be added to the trailer, up to the maximum weight specified on the placard. The combined weight of the cargo is provided as a single number. In any case, remember: the total weight of a fully loaded trailer cannot exceed the stated GVWR.

For trailers with living quarters installed, the weight of water and propane also need to be considered. The weight of fully filled propane containers is considered part of the weight of the trailer before it is loaded with cargo, and is not considered part of the disposable cargo load. Water, however, is a disposable cargo weight and is treated as such. If there is a fresh water storage tank of 100 gallons, this tank when filled would weigh about 800 pounds. If more cargo is being transported, water can be off-loaded to keep the total amount of cargo added to the vehicle within the limits of the GVWR so as not to overload the vehicle. Understanding this flexibility will allow you, the owner, to make choices that fit your travel needs.

When loading your cargo, be sure it is distributed evenly to prevent overloading front to back and side to side. Heavy items should be placed low and as close to the axle positions as reasonable. Too many items on one side may overload a tire. The best way to know the actual weight of the vehicle is to weigh it at a public scale. Talk

to your dealer to discuss the weighing methods needed to capture the various weights related to the trailer. This would include the weight empty or unloaded, weights per axle, wheel, hitch or king-pin, and total weight.

Excessive loads and/or underinflation cause tire overloading and, as a result, abnormal tire flexing occurs. This situation can generate an excessive amount of heat within the tire. Excessive heat may lead to tire failure. It is the air pressure that enables a tire to support the load, so proper inflation is critical. The proper air pressure may be found on the certification / VIN label and/or on the Tire Placard. This value should never exceed the maximum cold inflation pressure stamped on the tire.

Trailers 10,000 lbs (4,536 kg) GVWR or Less

1. Locate the statement "The weight of cargo should never exceed XXX kg or XXX lbs." on your vehicle's placard.
2. This figure equals the available amount of cargo and luggage load capacity.
3. Determine the combined weight of luggage and cargo being loaded on the vehicle. That weight may not safely exceed the available cargo and luggage load capacity.

Trailers over 10,000 lbs (4,536 kg) GVWR

NOTE: These trailers are not required to have a tire information placard on the vehicle.

4. Determine the empty weight of your trailer by weighing the trailer using a public scale or other means. This step does not have to be repeated.
5. Locate the GVWR of the trailer on your trailer's VIN (Certification) label.
6. Subtract the empty weight of your trailer from the GVWR stated on the VIN label. That weight is the maximum available cargo capacity of the trailer and may not be safely exceeded.

Steps for Determining Correct Load Limit – Tow Vehicle

1. Locate the statement "The combined weight of occupants and cargo should never exceed XXX kg or XXX lbs." on your vehicle's placard.
2. Determine the combined weight of the driver and passengers that will be riding in your vehicle.
3. Subtract the combined weight of the driver and passengers from XXX kg or XXX lbs.
4. The resulting figure equals the available amount of cargo and luggage load capacity. For example, if the "XXX" amount equals 1400 lbs. and there will be five 150 lb passengers in your vehicle, the amount of available cargo and luggage load capacity is 650 lbs. (1400-750 (5x150) = 650 lbs.)

5. Determine the combined weight of luggage and cargo being loaded on the vehicle. That weight may not safely exceed the available cargo and luggage load capacity calculated in Step 4.
6. If your vehicle will be towing a trailer, load from your trailer will be transferred to your vehicle. Consult the tow vehicle's manual to determine how this reduces the available cargo and luggage load capacity of your vehicle.

Glossary of Tire Terminology

Accessory weight means the combined weight (in excess of those standard items which may be replaced) of automatic transmission, power steering, power brakes, power windows, power seats, radio, and heater, to the extent that these items are available as factory-installed equipment (whether installed or not).

Bead means the part of the tire that is made of steel wires, wrapped or reinforced by ply cords and that is shaped to fit the rim.

Bead separation means a breakdown of the bond between components in the bead.

Bias ply tire means a pneumatic tire in which the ply cords that extend to the beads are laid at alternate angles substantially less than 90 degrees to the centerline of the tread.

Carcass means the tire structure, except tread and sidewall rubber which, when inflated, bears the load.

Chunking means the breaking away of pieces of the tread or sidewall.

Cord means the strands forming the plies in the tire.

Cord separation means the parting of cords from adjacent rubber compounds.

Cracking means any parting within the tread, sidewall, or inner liner of the tire extending to cord material.

Curb weight means the weight of a motor vehicle with standard equipment including the maximum capacity of fuel, oil, and coolant, and, if so equipped, air conditioning and additional weight optional engine.

Cold inflation pressure means the tire pressure when the vehicle hasn't been driven for at least three hours.

Extra load tire means a tire designed to operate at higher loads and higher inflation pressure than the corresponding standard tire.

Groove means the space between two adjacent tread ribs.

Gross Axle Weight Rating or GAWR means the value specified by the vehicle manufacturer as the load-carrying capacity of a single axle system, as measured at the tire-ground interfaces.

Gross Vehicle Weight Rating or GVWR means the value specified by the manufacturer as the loaded weight of a single vehicle.

Hitch weight means the downward force exerted on the hitch ball by the trailer coupler.

Inner liner means the layer(s) forming the inside surface of a tubeless tire that contains the inflating medium within the tire.

Inner liner separation means the parting of the inner liner cord material in the carcass.

Light truck (LT) tire means a tire designated by its manufacturer as primarily intended for use on lightweight trucks or multipurpose passenger vehicles.

Load rating means the maximum load that a tire is rated to carry for a given inflation pressure.

Maximum load rating means the load rating for a tire at the maximum permissible inflation pressure for that tire.

Maximum permissible inflation pressure means the maximum cold inflation pressure to which a tire may be inflated.

Maximum loaded vehicle weight means the sum of (a) Curb weight; (b) Accessory weight; (c) Vehicle capacity weight; and (d) Production options weight.

Measuring rim means the rim on which a tire is fitted for physical dimension requirements.

Non-pneumatic rim means a mechanical device which, when a non-pneumatic tire assembly incorporates a wheel, supports the tire, and attaches, either integrally or separably, to the wheel center member and upon which the tire is attached.

Non-pneumatic spare tire assembly means a non-pneumatic tire assembly intended for temporary use in place of one of the pneumatic tires and rims that are fitted to a passenger car in compliance with the requirements of this standard.

Non-pneumatic tire means a mechanical device which transmits, either directly or through a wheel or wheel center member, the vertical load and tractive forces from the roadway to the vehicle, generates the tractive forces that provide the directional control of the vehicle and does not rely on the containment of any gas or fluid for providing those functions.

Non-pneumatic tire assembly means a non-pneumatic tire, alone or in combination with a wheel or wheel center member, which can be mounted on a vehicle.

Normal occupant weight means 68 kilograms (150 lbs.) times the number of occupants specified in the second column of Table I of 49 CFR 571.110.

Occupant distribution means distribution of occupants in a vehicle as specified in the third column of Table I of 49 CFR 571.110.

Open splice means any parting at any junction of tread, sidewall, or inner liner that extends to cord material.

Outer diameter means the overall diameter of an inflated new tire.

Overall width means the linear distance between the exteriors of the sidewalls of an inflated tire, including elevations due to labeling, decorations, or protective bands or ribs.

Passenger car tire means a tire intended for use on passenger cars, multipurpose passenger vehicles, and trucks, that have a gross vehicle weight rating (GVWR) of 10,000 pounds or less.

Pin weight means the downward force applied to the 5th wheel or goose neck ball, by the trailer kingpin or goose neck coupler.

Ply means a layer of rubber-coated parallel cords.

Ply separation means a parting of rubber compound between adjacent plies.

Pneumatic tire means a mechanical device made of rubber, chemicals, fabric and steel or other materials, that, when mounted on an automotive wheel, provides the traction and contains the gas or fluid that sustains the load.

Production options weight means the combined weight of those installed regular production options weighing over 2.3 kilograms in excess of those standard items which they replace, not previously considered in curb weight or accessory weight, including heavy duty brakes, ride levelers, roof rack, heavy duty battery, and special trim.

Radial ply tire means a pneumatic tire in which the ply cords that extend to the beads are laid at substantially 90 degrees to the centerline of the tread.

Recommended inflation pressure means the proper Cold Inflation Pressure as shown on the Tire Information label.

Reinforced tire means a tire designed to operate at higher loads and at higher inflation pressures than the corresponding standard tire.

Rim means a metal support for a tire or a tire and tube assembly upon which the tire beads are seated.

Rim diameter means nominal diameter of the bead seat.

Rim size designation means rim diameter and width.

Rim type designation means the industry or manufacturer's designation for a rim by style or code.

Rim width means nominal distance between rim flanges.

Section width means the linear distance between the exteriors of the sidewalls of an inflated tire, excluding elevations due to labeling, decoration, or protective bands.

Sidewall means that portion of a tire between the tread and bead.

Sidewall separation means the parting of the rubber compound from the cord material in the sidewall.

ST tire means a tire designed for use only on trailers drawn on a road.

Test rim means the rim on which a tire is fitted for testing, and may be any rim listed as appropriate for use with that tire.

Tread means that portion of a tire that comes into contact with the road.

Tread rib means a tread section running circumferentially around a tire.

Tread separation means pulling away of the tread from the tire carcass.

Tread wear indicators (TWI) means the projections within the principal grooves designed to give a visual indication of the degrees of wear on the tread.

Vehicle capacity weight means the rated cargo and luggage load plus 68 kilograms times the vehicle's designated seating capacity.

Vehicle maximum load on the tire means that load on an individual tire that is determined by distributing to each axle its share of the maximum loaded vehicle weight and dividing by two.

Vehicle normal load on the tire means that load on an individual tire that is determined by distributing to each axle its share of the curb weight, accessory weight, and normal occupant weight (distributed in accordance with Table I of 49 CFR 571.110) and dividing by two.

Wheel center member means, in the case of a non-pneumatic tire assembly incorporating a wheel, a mechanical device which attaches, either integrally or separably, to the non-pneumatic rim and provides the connection between the non-pneumatic rim and the vehicle; or in the case of a non-pneumatic tire assembly not incorporating a wheel, a mechanical device which attaches, either integrally or separably, to the non-pneumatic tire and provides the connection between the tire and the vehicle.

Wheel-holding fixture means the fixture used to hold the wheel and tire assembly securely during testing.

Tire Safety

The National Traffic Safety Administration (NHTSA) has published a brochure (DOT HS 809 361) that discusses all aspects of Tire Safety, as required by 4 CFR 575.6. This brochure is reproduced in part below. It can be obtained and downloaded from NHTSA, free of charge, from the following website:

http://www.nhtsa.dot.gov/cars/rules/TireSafety/ridesonit/tires_index.html

Studies of tire safety show that maintaining proper tire pressure, observing tire and vehicle load limits (not carrying more weight in your vehicle than your tires or vehicle can safely handle), avoiding road hazards, and inspecting tires for cuts, slashes, and other irregularities are the most important things you can do to avoid tire failure, such as tread separation or blowout and flat tires. These actions, along with other care and maintenance activities, can also:

- Improve vehicle handling
- Help protect you and others from avoidable breakdowns and accidents

- Improve fuel economy
- Increase the life of your tires

This booklet presents a comprehensive overview of tire safety, including information on the following topics:

- Basic tire maintenance
- Uniform Tire Quality Grading System
- Fundamental characteristics of tires
- Tire safety tips

Use this information to make tire safety a regular part of your vehicle maintenance routine. Recognize that the time you spend is minimal compared with the inconvenience and safety consequences of a flat tire or other tire failure.

Basic Tire Maintenance

Properly maintained tires improve the steering, stopping, traction, and load-carrying capability of your vehicle. Under inflated tires and overloaded vehicles are a major cause of tire failure. Therefore, as mentioned above, to avoid flat tires and other types of tire failure, you should maintain proper tire pressure, observe tire and vehicle load limits, avoid road hazards, and regularly inspect your tires.

Finding Your Vehicle's Recommended Tire Pressure And Load Limits

Tire information placards and vehicle certification labels contain information on tires and load limits. These labels indicate the vehicle manufacturer's information including:

- Recommended tire size
- Recommended tire inflation pressure
- Vehicle capacity weight (VCW – the maximum occupant and cargo weight a vehicle is designed to carry)
- Front and rear gross axle weight ratings (GAWR – the maximum weight the axle systems are designed to carry)

Both placards and certification labels are permanently attached to the trailer near the left front.

Understanding Tire Pressure And Load Limits

Tire inflation pressure is the level of air in the tire that provides it with load-carrying capacity and affects the overall performance of the vehicle. The tire inflation pressure is a number that indicates the amount of air pressure – measured in pounds per square inch (psi) – a tire requires to be properly inflated. (You will also find this number on the vehicle information placard expressed in kilopascals (kpa), which is the metric measure used internationally.)

Manufacturers of passenger vehicles and light trucks determine this number based on the vehicle's design load limit, that is, the greatest amount of weight a vehicle can safely carry and the vehicle's tire size. The proper

tire pressure for your vehicle is referred to as the “recommended cold inflation pressure.” (As you will read below, it is difficult to obtain the recommended tire pressure if your tires are not cold.)

Because tires are designed to be used on more than one type of vehicle, tire manufacturers list the “maximum permissible inflation pressure” on the tire sidewall. This number is the greatest amount of air pressure that should ever be put in the tire under normal driving conditions.

Checking Tire Pressure

It is important to check your vehicle’s tire pressure at least once a month for the following reasons:

- Most tires may naturally lose air over time.
- Tires can lose air suddenly if you drive over a pothole or other object or if you strike the curb when parking.
- With radial tires, it is usually not possible to determine underinflation by visual inspection.

For convenience, purchase a tire pressure gauge to keep in your vehicle. Gauges can be purchased at tire dealerships, auto supply stores, and other retail outlets.

The recommended tire inflation pressure that vehicle manufacturers provide reflects the proper psi when a tire is cold. The term cold does not relate to the outside temperature. Rather, a cold tire is one that has not been driven on for at least three hours.

When you drive, your tires get warmer, causing the air pressure within them to increase. Therefore, to get an accurate tire pressure reading, you must measure tire pressure when the tires are cold or compensate for the extra pressure in warm tires.

Steps For Maintaining Proper Tire Pressure

1. Locate the recommended tire pressure on the vehicle’s tire information placard, certification label, or in the owner’s manual.
2. Record the tire pressure of all tires.
3. If the tire pressure is too high in any of the tires, slowly release air by gently pressing on the tire valve stem with the edge of your tire gauge until you get to the correct pressure.
4. If the tire pressure is too low, note the difference between the measured tire pressure and the correct tire pressure. These “missing” pounds of pressure are what you will need to add.
5. At a service station, add the missing pounds of air pressure to each tire that is under inflated.
6. Check all the tires to make sure they have the same air pressure (except in cases in which the front and rear tires are supposed to have different amounts of pressure).

If you have been driving your vehicle and think that a tire is under inflated, fill it to the recommended cold inflation pressure indicated on your vehicle’s tire information

placard or certification label. While your tire may still be slightly under inflated due to the extra pounds of pressure in the warm tire, it is after to drive with air pressure that is slightly lower than the vehicle manufacturer’s recommended cold inflation pressure than to drive with a significantly under inflated tire. Since this is a temporary fix, don’t forget to recheck and adjust the tire’s pressure when you can obtain a cold reading.

Tire Size

To maintain tire safety, purchase new tires that are the same size as the vehicle’s original tires or another size recommended by the manufacturer. Look at the tire information placard, the owner’s manual, or the sidewall of the tire you are replacing to find this information. If you have any doubt about the correct size to choose, consult with the tire dealer.

Tire Tread

The tire tread provides the gripping action and traction that prevent your vehicle from slipping or sliding, especially when the road is wet or icy. In general, tires are not safe and should be replaced when the tread is worn down to 1/16 of an inch. Tires have built-in tread wear indicators that let you know when it is time to replace your tires. These indicators are raised sections spaced intermittently in the bottom of the tread grooves. When they appear “even” with the outside of the tread, it is time to replace your tires. Another method for checking tread depth is to place a penny in the tread with Lincoln’s head upside down and facing you. If you can see the top of Lincoln’s head, you are ready for new tires.

Tire Balance And Wheel Alignment

To avoid vibration or shaking of the vehicle when a tire rotates, the tire must be properly balanced. This balance is achieved by positioning weights on the wheel to counterbalance heavy spots on the wheel-and-tire assembly. A wheel alignment adjusts the angles of the wheels so that they are positioned correctly relative to the vehicle’s frame. These adjustments require special equipment and should be performed by a qualified technician.

Tire Repair

The proper repair of a punctured tire requires a plug for the hole and a patch for the area inside the tire that surrounds the puncture hole. Punctures through the tread can be repaired if they are not too large, but punctures to the sidewall should not be repaired. Tires must be removed from the rim to be properly inspected before being plugged and patched.

Tire Fundamentals

Federal law requires tire manufacturers to place standardized information on the sidewall of all tires. This information identifies and describes the fundamental

characteristics of the tire and also provides a tire identification number for safety standard certification and in case of a recall.

Information on Passenger Vehicle Tires

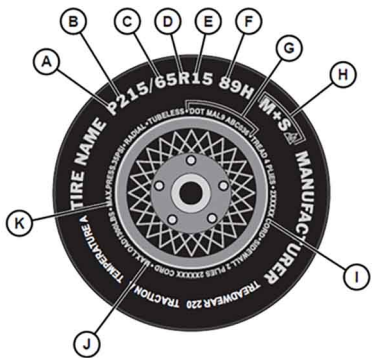

014608

Figure 7-1. Passenger Vehicle Tires

A	"P" indicates the tire is for passenger vehicles.
B	This three-digit number gives the width in millimeters of the tire from sidewall edge to sidewall edge. In general, the larger the number, the wider the tire.
C	This two-digit number, known as the aspect ratio, gives the tire's ratio of height to width. Numbers of 70 or lower indicate a short sidewall for improved steering response and better overall handling on dry pavement.
D	"R" stands for radial. Radial ply construction of tires has been the industry standard for the past 20 years.
E	This two-digit number is the wheel or rim diameter in inches. If you change your wheel size, you will have to purchase new tires to match the new wheel diameter.
F	(Number) This two- or three-digit number is the tire's load index. It is a measurement of how much weight each tire can support. You may find this information in your owner's manual. If not, contact a local tire dealer. NOTE: You may not find this information on all tires because it is not required by law. (Letter) The speed rating denotes the speed at which a tire is designed to be driven for extended periods of time. The ratings range from 99 miles per hour (mph) to 186 mph. These ratings are listed below. NOTE: You may not find this information on all tires because it is not required by law. NOTE: See Figure 7-1 for complete list of letter and speed ratings.

G	U.S. DOT Tire Identification Number. This begins with the letters "DOT" and indicates that the tire meets all federal standards. The next two numbers or letters are the plant code where it was manufactured, and the last four numbers represent the week and year the tire was built. For example, the numbers 3197 means the 31st week of 1997. The other numbers are marketing codes used at the manufacturer's discretion. This information is used to contact consumers if a tire defect requires a recall.
H	The "M+S" or "M/S" indicates that the tire has some mud and snow capability. Most radial tires have these markings; hence, they have some mud and snow capability.
I	Tire Ply Composition and Materials Used. The number of plies indicates the number of layers of rubber-coated fabric in the tire. In general, the greater the number of plies, the more weight a tire can support. Tire manufacturers also must indicate the materials in the tire, which include steel, nylon, polyester, and others.
J	Maximum Load Rating. This number indicates the maximum load in kilograms and pounds that can be carried by the tire.
K	Maximum Permissible Inflation Pressure. This number is the greatest amount of air pressure that should ever be put in the tire under normal driving conditions.

Table 7-1. Tire Letter and Speed Rating

Letter Rating	Speed Rating
Q	99 MPH
R	106 MPH
S	112 MPH
T	118 MPH
U	124 MPH
H	130 MPH
V	168 MPH
Y	186 MPH

NOTE: For tires with a maximum speed capability over 149 mph, tire manufacturers sometimes use the letters ZR. For those with a maximum speed capability over 186 mph, tire manufacturers always use the letters ZR.

Uniform Tire Quality Grading (UTQGS)

Quality grades can be found where applicable on the tire sidewall between tread shoulder and maximum section width. For example: TREADWEAR 200 TRACTION AA.

Temperature A

All passenger car tires must conform to federal safety requirements in addition to these grades.

Tread wear

The tread wear grade is a comparative rating based on the wear rate of the tire when tested under controlled conditions on a specified government test course. For example, a tire graded 150 would wear one and one-half (1.5) times as well on the government course as a tire graded 100. The relative performance of tires depends upon the actual conditions of their use, however, and may depart significantly from the norm due to variations in driving habits, service practices and differences in road characteristics and climate.

Traction

The traction grades, from highest to lowest, are AA, A, B, and C. Those grades represent the tire’s ability to stop on wet pavement as measured under controlled conditions on specified government test surfaces of asphalt and concrete. A tire marked C may have poor traction performance.

NOTE: The traction grade assigned to this tire is based on straight-ahead braking traction tests, and does not include acceleration, cornering, hydroplaning, or peak traction characteristics.

Temperature

The temperature grades are A (the highest), B, and C, representing the tire’s resistance to the generation of heat and its ability to dissipate heat when tested under controlled conditions on a specified indoor laboratory test wheel. Sustained high temperature can cause the material of the tire to degenerate and reduce tire life, and excessive temperature can lead to sudden tire failure. The grade C corresponds to a level of performance which all passenger car tires must meet under the Federal Motor Safety Standard No.109. Grades B and A represent higher levels of performance on the laboratory test wheel than the minimum required by law.

NOTE: The temperature grade for this tire is established for a tire that is properly inflated and not overloaded. Excessive speed, under-inflation, or excessive loading, either separately or in combination, can cause heat buildup and possible tire failure.

Additional Information on Light Truck Tires

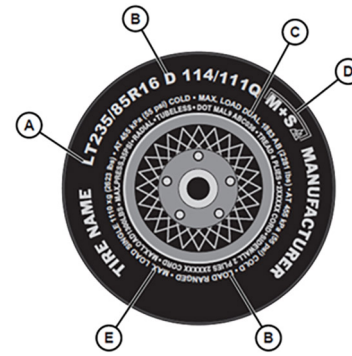

014609

Figure 7-2. Light Truck Tires

A	The “LT” indicates the tire is for light trucks. An “ST” is an indication the tire is for trailer use only.
B	Load Range. This information identifies the tire’s load-carrying capabilities and its inflation limits.
C	Maximum Load Dual. This information indicates the maximum load and tire pressure when the tire is used as a dual, that is, when four tires are put on each rear axle (a total of six or more tires on the vehicle).*
D	The “M+S” or “M/S” indicates that the tire has some mud and snow capability. Most radial tires have these markings; hence, they have some mud and snow capability.
E	This information indicates the maximum load and tire pressure when the tire is used as a single.*

* Maximum load is presented in kilograms and pounds (kg/lbs). Maximum tire pressure is presented in kilopascals and pounds per square inch (kPa/psi) for when the tire is cold.

Preventing Tire Damage

- Slow down if you have to go over a pothole or other object in the road.
- Do not run over curbs of foreign objects in the roadway, and try not to strike the curb when parking.

Tire Safety Checklist

- Check tire pressure regularly (at least once a month), including the spare.

- Inspect tires for cracks, foreign objects, uneven wear patterns on the tread, or other signs of wear or trauma.
- Remove bits of glass and foreign objects wedged in the tread.
- Verify your tire valves have valve caps.
- Check tire pressure before going on a long trip.
- Do not overload your vehicle. Check the tire information placard or owner's manual for the maximum recommended load for the vehicle.

Part No. A0000389937 Rev D 11/06/2024

©2024 Generac Power Systems, Inc.

All rights reserved.

Specifications are subject to change without notice.

No reproduction allowed in any form without prior written consent from
Generac Power Systems, Inc.

GENERAC | **MOBILE**

Generac Power Systems, Inc.
S45 W29290 Hwy. 59, Waukesha WI 53189
GeneracMobileProducts.com | 844-ASK-GNRC | 844-275-4672