

MDG100DF4 | 4.5 L | 100 kVA

MOBILE DIESEL GENERATOR SET

EPA Emissions Certification: Tier 4 Final

GENERAC | MOBILE

Standby Power Rating

85 kW, 106 kVA, 60 Hz

Prime Power Rating

80 kW, 100 kVA, 60 Hz



*Assembled in the USA using domestic and foreign parts



Picture shown may not reflect actual configuration

Codes and Standards

Generac Mobile products are designed to the following standards:



CSA



NATM



TIER 4 FINAL EMISSIONS



UL142, ULC-S601 CERTIFIED

Power When You and Where You Need It

Generac Mobile generators are designed and engineered to power a variety of projects, in the most extreme environments. Gensets are configured to meet customer needs, including choice of containment, cold weather packages, trailer options, and more.

Generac Mobile generators are manufactured to deliver reliable power, when and where you need it.

STANDARD FEATURES

ENGINE SYSTEM

- John Deere® 4045HFG04
- 4 cylinder
- Turbocharged & Aftercooled
- 275 in3 (4.5 L) Displacement
- EPA Tier 4 Final
- Power @ 1,800 RPM -hp (kW):
 - Prime: 122 (90)
 - Standby: 133 (99)
- Paper Element Air Filter
- Electronic Isochronous Governing
- Variable Speed Fan
- Spin On Cartridge Oil Filter
- Oil Drain Extension
- One CCV System Filter
- One Fuel Filters
- One Fuel-Water Separator Filter
- One 12 V, 720 CCA, Wet Cell Battery

COOLING SYSTEM

- Capable of Operating at 104 °F (40 °C) Ambient
- 50/50 Coolant (50% Ethylene Glycol)
- Coolant Drain Extension

FUEL SYSTEM

- Single Wall Fuel Tank
- Fuel tank capacity — US gal (L):
 - Total: 165 (625)
 - Usable: 146 (552)

- Maximum Runtime @ 75% load: 32 hr
- DEF Tank Capacity – US gal (L):
 - Total: 12 (45.4)
 - Usable: 9.1 (34.4)
- Padlockable Fuel and DEF Tank Caps

CONTROL SYSTEM

- Deep Sea Electronics® 7310 MKII Controller
- 3-Position Voltage Selection Switch
- 400 A Main Circuit Breaker (MCB), Manual, with Shunt Trip
- Individual Convenience Receptacle Circuit Breakers
- Emergency Stop Switch
- Remote 2-wire Start/Stop Contacts

ALTERNATOR SYSTEM

- 60 Hz Engine-Driven Alternator
- Standard Alternator
 - Brushless
 - 4 Pole
 - 2/3 pitch
 - Class H insulation
 - Corrosion Protection
- Marathon Electric® PM500 AVR
- Shunt Excitation System

POWER DISTRIBUTION

- Connection Lugs

- Convenience Receptacles
 - Two 120 V, 20 A, GFCI Duplex (NEMA 5-20R)
 - Three 120/240 V, 50 A, 3 Pole, 4 Wire Twist-lock (CS6369)

ENCLOSURE

- Aluminum, Sound Attenuated Enclosure, Insulated and Baffled
- UV and Fade Resistant, High Temperature Cured, White Polyester Powder Paint
- Central Lifting Point
- Fully Lockable Enclosure
- Multi Lingual Operating and Safety Decals
- Document Holder with Owner's Manual - includes AC and DC wiring diagrams

TRAILER

- Hydraulic Surge Brakes
- 3 in (76.2 mm) Pintle Ring
- Tires: ST225/75, 15 in. Rim
- Heavy Duty Trailer Jack
- Safety Chains with Spring Loaded Safety Hooks
- Transportation Tie Downs
- Plug Adapter, Round 7 Spade (SAE J2863)
- DOT Approved Tail, Side, Brake, and Directional Lights

WARRANTY

- 2 year limited or 2,000 hours
 - Unlimited hours covered in first year

CONTROL SYSTEM

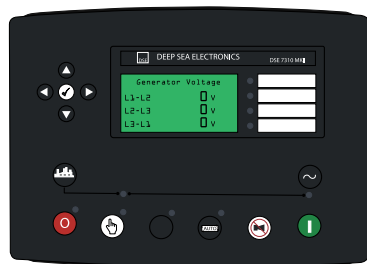

Deep Sea Electronics CONTROLLER AND DISPLAY

- Model DSE7310 MKII
- 4 Line Back Lit LCD Text Display
- -40 to 158 °F (-40 to 70 °C) Operating Temperature Range
- Multiple Language Options
- Configurable Timers and Alarms
- Configurable Start/Stop Timers
- Configurable Maintenance Alarms
- Heated Display

PUSH BUTTONS FOR EASY OPERATION

- Manual or Auto Start
- Engine Start
- Engine Stop/Reset
- User Friendly Setup and Button Layout
- Five Key Menu Navigation
- Multiple Parameters are Monitored and Displayed Simultaneously for Full Visibility
- View Controller Parameters (Configuration, Firmware Version, Connections)

ELECTRICAL CONTROLS

- Lockable Control Box Door with Diagnostics Window
- Lockable lug box with safety switch
 - Trips main breaker when door is opened
 - Disables voltage regulator
- Output ground connection lug inside lug box
- Voltage adjustment ±10%

LCD ALARM INDICATION

- Generator Diagnostic Display

- System kVA Output Display
- Line Output and Frequency Display
- Alarm Types: Warning, Shutdown, Electrical Trip, Engine
- Alarm List – Warnings/Shutdowns; 250 Event History Log – Date/Time Stamped
 - Fuel Level: Warning – 15%; Shutdown – 5%
 - Overspeed Protection: Shutdown – 110%
 - Engine Diagnostic Warnings Communicated Through J1939 CANbus
 - Battery Voltage: Over – 15 VDC; Under – 11 VDC
 - Generator Over Voltage: Warning – 110%; Electrical Trip – 115%
 - Generator Under Voltage: Warning – 90%; Shutdown – 85%
 - Generator Over Frequency: Warning – 105%; Electrical Trip – 110%
 - Generator Under Frequency: Warning – 95%; Electrical Trip – 90%
- Auto Schedule
- Status

MDG100DF4 | 4.5 L | 100 kVA

MOBILE DIESEL GENERATOR SET

EPA Emissions Certification: Tier 4 Final

GENERAC® | **MOBILE**

CONFIGURABLE OPTIONS*

ENGINE SYSTEM

- o Positive Air Shutdown (PAS), Electronic
- o Oil Evacuation System - requires customer-sourced, specialized equipment to use for oil change

COLD WEATHER

- o Engine Block Heater - included with selection of any other CW heater option
- o Two Heated Fuel Filters
- o Oil Heater
- o Crankcase Ventilation (CCV) System Heater
- o Battery Heater
- o 10 A Battery Charger
- o 60/40 Coolant (60% Ethylene Glycol)

CONTROL SYSTEM

- o 4-Position Voltage Selection Switch
- o Paralleling Capability
 - Deep Sea Electronics® 8610 MKII Controller
 - 400 A Main Circuit Breaker (MCB), Motorized, with Shunt Trip
 - Mobile Switching Center (MSC) Cable Connections
- o Telemetry
- o Lojack Equipment Recovery System
- o Battery Disconnect Switch

FUEL SYSTEM

- o Containment Pan - for use with standard single wall fuel tank
 - 110% Containment - engine fluid (oil, coolant, & DEF) and fuel
- o Double Wall Fuel Tank
 - 110% Containment - engine fluid (oil, coolant, & DEF) and fuel
 - UN31A Certification
 - UL142/ULC-S601 Certification
- o Fuel Tank Capacity - gal (L)
 - Total: 128 (485)
 - Usable: 120 (454)
- o Runtime @ 75% load: 26.5 hr
- o Engine Fluid & Fuel Leak Detection Sensor - option available only with selection of double wall fuel tank option

ALTERNATOR SYSTEM

- o SUPERSTART® Alternator
- o VFLEX (600 V) Alternator
- o Marathon Electric® DVR2400 DVR
- o Permanent Magnet Generator (PMG) Excitation System

POWER DISTRIBUTION

- o Camlocks—Six Sets, Female (US or Canada Color Code)
- o Buck Transformer

ENCLOSURE

- o Control Panel Lights
- o Interior Lights
- o Fire Extinguisher

TRAILER

- o Skid Mount (Non-trailer)
- o Electric Brakes
- o Tandem Axle
- o 2-5/16 in. (58.7 mm) Ball Hitch, Adjustable
- o 2 in. (50.8 mm) Ball Hitch, Adjustable
- o Rear Stabilizer Jacks
- o Toolbox Aluminum, 49 x 15 x 18.5 in. (125 x 38 x 47 cm)
- o Spare Tire

RATING DEFINITIONS

Standby: Applicable to varying emergency load for the duration of a utility power outage.

Prime: Applicable to supplying power to a varying load in lieu of utility for an unlimited amount of running time.

*Consult factory for availability



APPLICATION AND ENGINEERING DATA

ENGINE SPECIFICATIONS

General

Make (Model)	John Deere (4045HFG04)
EPA Emissions Compliance	Tier 4 Final
After Treatment System	DOC and SCR
Cylinder #	4
Type	In-line
Displacement: in ³ (L)	275 (4.5)
Bore: in (mm)	4.2 (10.6)
Stroke: in (mm)	5.0 (12.7)
Compression Ratio	17:1
Intake Air Method	Turbocharged & Aftercooled

Engine Governing

Governor	Electronic
Frequency Regulation (Steady State)	2%

Lubrication System

Oil Pump	Gear Driven
Oil Filter Type	Spin-On Cartridge, Full Flow
Engine Oil Capacity: qt (L)	15.9 (15)

Cooling System

Cooling System Type	Radiator and CAC
Water Pump Type	Engine Belt Driven
Fan Type	Pusher
Fan Speed: RPM	Variable Speed Clutch
Fan Diameter: in (mm)	23.2 (59.0)
Cooling System Capacity — qt (L)	22.0 (20.8)

Fuel System

Fuel Type	Ultra Low Sulfur Diesel
Fuel Specifications	EN 590 / ASTM D975
Fuel Filtering	Primary: 10 Final: 2
Fuel Injection Pump – Make (Model)	Denso (HP3)
Fuel Pump Type	Engine Gear Driven
Injector Type	Electronic
Engine Type	Direct Injection High Pressure Common Rail
Fuel Supply Line Diameter – in (mm)	0.375 (9.5)
Fuel Return Line Diameter – in (mm)	0.375 (9.5)

Engine Electrical System

System Voltage: VDC	12
Battery Charger Alternator – VDC (A)	12 (90)
Battery – CCA	720
Battery – V (Qty)	12 (1)
Ground Polarity	Negative (-)

STANDARD ALTERNATOR SPECIFICATIONS

Make (Model)	Marathon Electric (362CSL1606)
Poles	4
Field Type	Rotating
Insulation Class — Rotor	Class H
Insulation Class — Stator	Class H
Total Harmonic Distortion (THD)	< 3.5%
Telephone Interference Factor (TIF)	< 50

Standard Excitation	Shunt
Bearings	Single Bearing
Coupling	Direct Flexible Disc
Prototype Short Circuit Test	Yes
Voltage Regulator Type	AVR
Quantity of Sensed Phases	1
Regulation Accuracy (Steady State)	± 0.5%

SUPERSTART ALTERNATOR SPECIFICATIONS

Make (Model)	Marathon Electric (362PSL1650)
Poles	4
Field Type	Rotating
Insulation Class — Rotor	Class H
Insulation Class — Stator	Class H
Total Harmonic Distortion (THD)	< 3.5%
Telephone Interference Factor (TIF)	< 50

Standard Excitation	Shunt
Bearings	Single Bearing
Coupling	Direct Flexible Disc
Prototype Short Circuit Test	Yes
Voltage Regulator Type	AVR
Quantity of Sensed Phases	1
Regulation Accuracy (Steady State)	± 0.5%

APPLICATION AND ENGINEERING DATA (CONTINUED)

VFLEX ALTERNATOR SPECIFICATIONS

Make (Model)	Marathon Electric (362PSL36115)	Standard Excitation	Shunt
Poles	4	Bearings	Single Bearing
Field Type	Rotating	Coupling	Direct Flexible Disc
Insulation Class — Rotor	Class H	Prototype Short Circuit Test	Yes
Insulation Class — Rotor	Class H	Voltage Regulator Type	AVR
Total Harmonic Distortion (THD)	<3.5%	Quantity of Sensed Phases	1
Telephone Interference Factor (TIF)	<50	Regulation Accuracy (Steady State)	± 0.5%

OPERATING DATA

POWER RATINGS

	Standard Alternator		SUPERSTART Alternator		VFLEX Alternator	
	Standby:	Prime:	Standby:	Prime:	Standby:	Prime:
	kW/kVA (A)	kW/kVA (A)	kW/kVA (A)	kW/kVA (A)	kW/kVA (A)	kW/kVA (A)
1-phase, 120/240 VAC @ 1.0 pf-zig zag*	78/78 (325)	78/78 (325)	78/78 (325)	78/78 (325)	40/40 (166)	40/40 (166)
3-phase, 120/208 VAC @ 0.8 pf-low wye	85/106 (295)	80/100 (278)	85/106 (295)	80/100 (278)	83/104 (288)	78/98 (271)
3-phase, 120/240 VAC @ 0.8 pf-delta**	85/106 (256)	80/100 (241)	85/106 (256)	80/100 (241)	83/104 (250)	78/98 (235)
3-phase, 277/480 VAC @ 0.8 pf-high wye	85/106 (128)	80/100 (120)	85/106 (128)	80/100 (120)	85/106 (128)	80/100 (120)
3-phase, 346/600 VAC @ 0.8 pf-high wye	N/A	N/A	N/A	N/A	85/106 (102)	80/100 (96)

*Alternator limited.

**Power ratings achieved through use of optional 4-position voltage selection switch.

FUEL CONSUMPTION RATES

Prime Load	Fuel: gph (L/hr)	DEF: gph (L/hr)
25%	1.9 (7.2)	0.07 (0.26)
50%	3.2 (12.1)	0.13 (0.49)
75%	4.5 (17.0)	0.20 (0.76)
100%	6.0 (22.7)	0.26 (0.98)
110% (Standby)	6.4 (24.2)	0.31 (1.17)

Deration – Operational characteristics consider maximum ambient conditions. Derate factors may apply under atypical site conditions.

Please consult a Generac Mobile Authorized Service Dealer for additional details. All performance ratings in accordance with ISO3046, BS5514, ISO8528, ISO8665, ISO3046, SAE J1228, SAE J1995, and DIN6271 standards.

MDG100DF4 | 4.5 L | 100 kVA

MOBILE DIESEL GENERATOR SET

EPA Emissions Certification: Tier 4 Final



DIMENSIONS AND WEIGHTS*

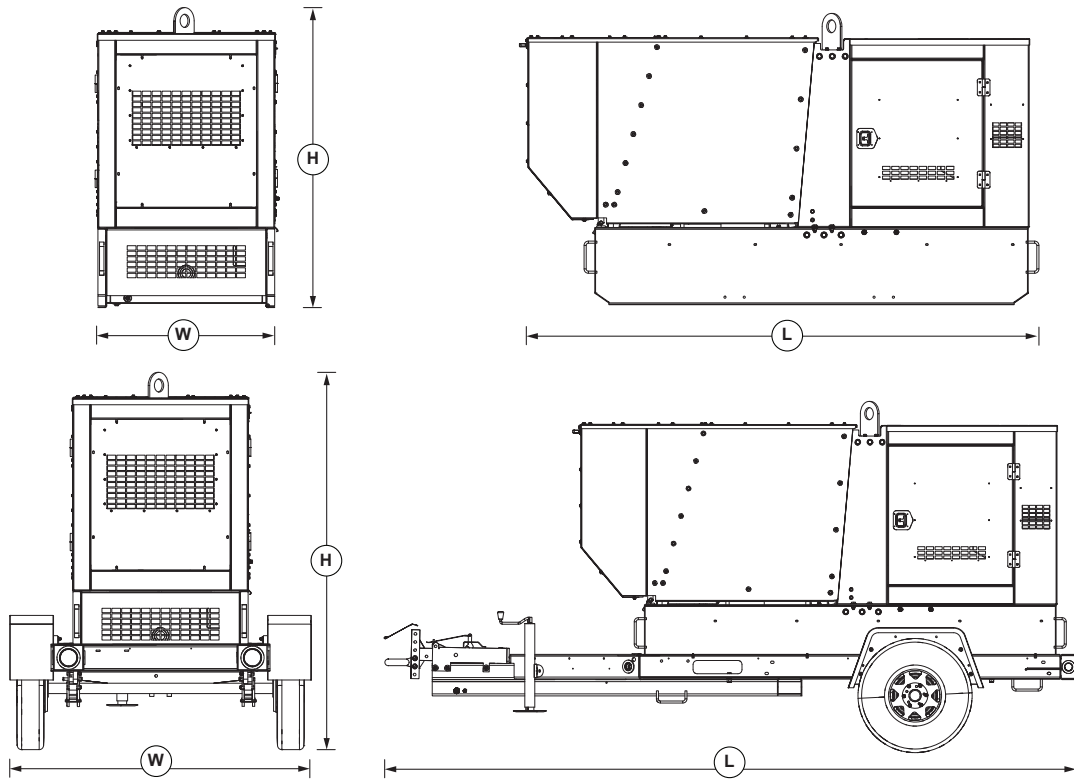

	Runtime: hr*	Usable Fuel Capacity: gal (L)	Dimensions – L×W×H: in (m)	Weight: lb (kg)
Skid	32	146 (552)	119 (3.02)×40 (1.02)×62 (1.57)	Dry: 3,980 (1,805) Operating: 4,940 (2,240)
Trailer	32	146 (552)	170 (4.31)×69 (1.75)×80 (2.03)	Dry: 4,680 (2,122) Operating: 5,640 (2,555)

*Runtime based on 75% of prime rated power

SOUND RATING

- 74 dB(A) @ 23 ft (7 m) @ prime power

* All measurements are approximate and for estimation purposes only.

YOUR FACTORY RECOGNIZED GENERAC MOBILE DEALER

Specification characteristics may change without notice. Dimensions and weights are for preliminary purposes only. Please consult a Generac Mobile Authorized Service Dealer for detailed installation drawings.