

# ***MFH900***

## ***Flameless Air Heater***

### ***Owner's Manual***

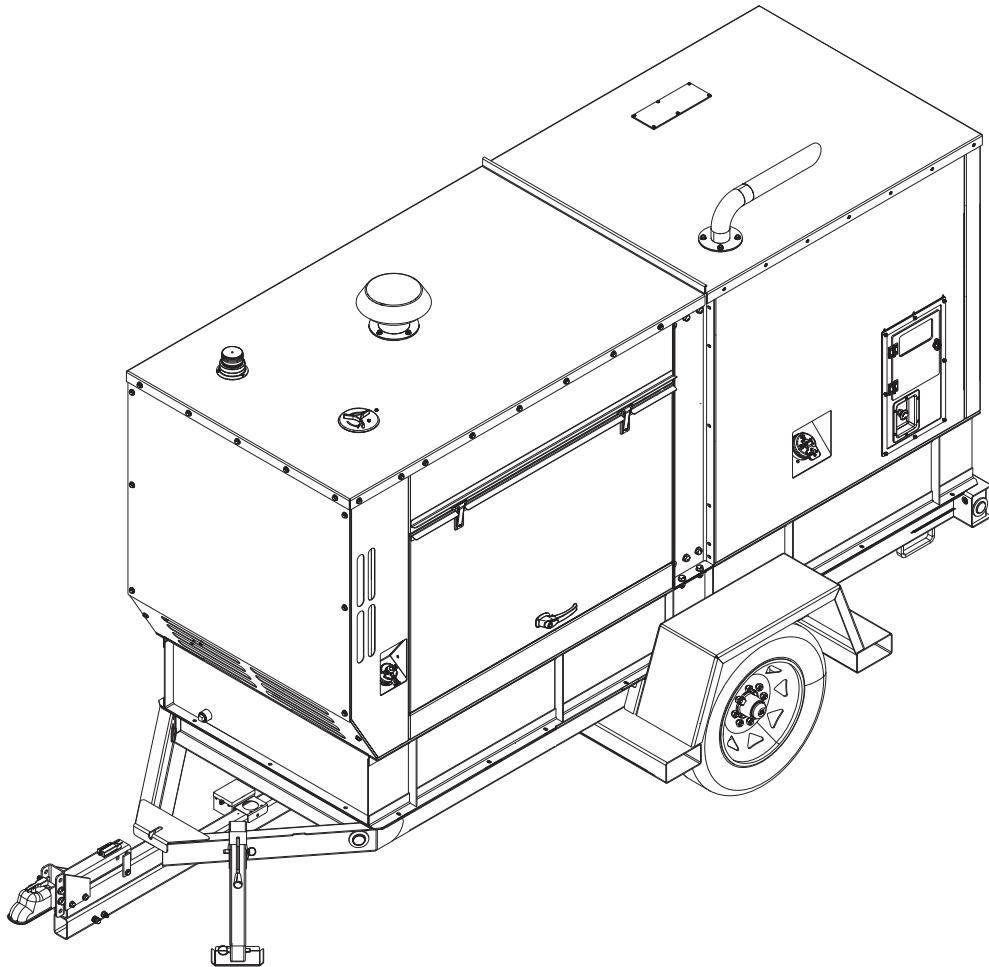

For technical assistance contact:

[www.generacmobileproducts.com](http://www.generacmobileproducts.com)

Technical Support

1-800-926-9768

***SAVE THIS MANUAL FOR FUTURE REFERENCE***

---

**Use this page to record important information about your unit**

Unit Model No.	
Unit Serial No.	
Engine Model No.	
Engine Serial No.	
Generator Model No.	
Generator Serial No.	

Record the information found on your unit data label on this page. See Unit Serial Number Locations.

Engine and generator serial numbers are located on data plates affixed to the engine and generator, respectively. When contacting a Generac Mobile Authorized Service Dealer (GMASD) about parts and service, always provide the unit model and serial number.

**Operation and Maintenance:** Proper maintenance and care of the unit ensures a minimum number of problems and keeps operating expenses at a minimum. It is the operator's responsibility to perform all safety checks, to verify that all maintenance for safe operation is performed promptly, and to have the equipment checked periodically by a GMASD. Normal maintenance, service, and replacement of parts are the responsibility of the owner/operator and, as such, are not considered defects in materials or workmanship within the terms of the warranty. Individual operating habits and usage may contribute to the need for additional maintenance or service.

 **WARNING****CANCER AND REPRODUCTIVE HARM**

[www.P65Warnings.ca.gov](http://www.P65Warnings.ca.gov)

(000393a)

 **WARNING**

Breathing diesel engine exhaust exposes you to chemicals known to the State of California to cause cancer and birth defects or other reproductive harm.

- Always start and operate the engine in a well-ventilated area.
- If in an enclosed area, vent the exhaust to the outside.
- Do not modify or tamper with the exhaust system.
- Do not idle the engine except as necessary.

For more information go to

[www.P65Warnings.ca.gov/diesel](http://www.P65Warnings.ca.gov/diesel) (000394)

# Table of Contents

<b>Section 1: Introduction and Safety</b> .....	<b>1</b>	<b>Section 3: Operation</b> .....	<b>19</b>
<b>Introduction</b> .....	<b>1</b>	<b>Before Starting Engine</b> .....	<b>19</b>
Read This Manual Thoroughly .....	1	Pre-start Checklist .....	19
<b>Safety Rules</b> .....	<b>1</b>	Engine Oil Check .....	19
How to Obtain Service .....	1	Hydraulic Oil Check .....	19
<b>General Hazards</b> .....	<b>2</b>	Engine Coolant Check .....	19
<b>Explosion and Fire Hazards</b> .....	<b>2</b>	Battery Check .....	19
<b>Trailer Hazards</b> .....	<b>3</b>	<b>Starting Engine and Heater</b> .....	<b>20</b>
<b>Battery Hazards</b> .....	<b>3</b>	<b>Adjusting Air Output Temperature</b> .....	<b>20</b>
<b>Service Safety</b> .....	<b>3</b>	<b>Adjusting Heater CFM</b> .....	<b>21</b>
<b>Towing Safety</b> .....	<b>3</b>	<b>Changing Controller Mode</b> .....	<b>21</b>
Hitch and Coupling .....	4	<b>Shutting Down Engine and Heater</b> .....	<b>21</b>
Running Lights .....	4	<b>Emergency Stop Switch</b> .....	<b>22</b>
Safe Towing Techniques .....	4	<b>Battery Disconnect Switch</b> .....	<b>22</b>
<b>Reporting Trailer Safety Defects</b> .....	<b>4</b>	<b>Before Towing Unit</b> .....	<b>22</b>
<b>Section 2: General Information</b> .....	<b>5</b>	<b>Section 4: Maintenance</b> .....	<b>23</b>
<b>Specifications</b> .....	<b>5</b>	<b>Maintenance Tasks</b> .....	<b>23</b>
<b>Unit Dimensions</b> .....	<b>6</b>	Daily Walk Around Inspection .....	23
<b>Unit Serial Number Locations</b> .....	<b>6</b>	Checking Engine Oil Level .....	23
<b>Component Locations</b> .....	<b>7</b>	Draining Fluids—Union Fluid Drain .....	24
Exterior .....	7	Adding Coolant .....	24
Interior .....	8	Removing Crankcase Filter .....	25
<b>Control Panel</b> .....	<b>10</b>	Engine Diagnostic Port and ECM (Engine Control Module) .....	25
<b>Controller</b> .....	<b>11</b>	<b>Maintenance Schedule</b> .....	<b>26</b>
Controller Display: Alert (Icon) Definitions .....	12	Engine Maintenance Schedule .....	26
Controller Faceplate Icons .....	13	Hydraulic Oil Schedule .....	27
<b>Emissions Information</b> .....	<b>13</b>	Hydraulic Oil Filters Schedule .....	27
<b>Engine Oil Recommendations</b> .....	<b>13</b>	Accessing and Resetting Controller Service Intervals .....	27
<b>Coolant Recommendation</b> .....	<b>13</b>	<b>Other Maintenance Checks</b> .....	<b>28</b>
<b>Fuel System</b> .....	<b>14</b>		
<b>Hydraulic Oil</b> .....	<b>14</b>		
<b>Trailer Towing Guidelines</b> .....	<b>14</b>		
Wheel Chock Guidelines .....	14		
<b>Rooftop Beacon</b> .....	<b>15</b>		
<b>Home Page (Default Operator Display)</b> .....	<b>15</b>		
Controller Mode .....	15		
Controller Monitoring, Diagnostic, and Protective Features .....	17		
Advanced Controller Functions .....	18		
		<b>Section 5: Troubleshooting</b> .....	<b>29</b>
		<b>General Troubleshooting Guide</b> .....	<b>29</b>
		<b>Controller Warnings and Faults</b> .....	<b>32</b>
		<b>Section 6: Wiring Diagrams</b> .....	<b>35</b>
		<b>Main Control System</b> .....	<b>35</b>
		<b>Perkins Engine Aftertreatment</b> .....	<b>36</b>
		<b>J1939 CAN Bus Network</b> .....	<b>37</b>
		<b>Trailer Harness—Electric Brakes</b> .....	<b>38</b>
		<b>Trailer Harness—Lights Only or With Surge Brakes</b> .....	<b>39</b>
		<b>Hydraulic Circuit</b> .....	<b>41</b>

---

**This page intentionally left blank.**

# Section 1: Introduction and Safety

---

## Introduction

Thank you for purchasing a Generac Mobile product. This unit has been designed to provide high-performance, efficient operation, and years of quality use when maintained properly.

The MFH900 flameless air heater is designed and built for sustained, reliable heat production in industrial operating conditions and environments. The MFH900 is built to withstand frequent handling under these conditions.

The unit is mounted on a trailer that has forklift pockets, tie-down points, and a central lifting point. The fully enclosed design protects the operating components, allowing all-weather storage and operations.

The information in this manual is accurate based on products produced at the time of publication. The manufacturer reserves the right to make technical updates, corrections, and product revisions at any time without notice.

## Read This Manual Thoroughly



Consult Manual. Read and understand manual completely before using product. Failure to completely understand manual and product could result in death or serious injury.

(000100a)

If any section of the manual is not understood, contact your nearest Generac Mobile Authorized Service Dealer (GMP ASD), or contact Generac Mobile customer service at 800-926-9768, or visit [www.generacmobileproducts.com](http://www.generacmobileproducts.com) with any questions or concerns.

The owner is responsible for proper maintenance and safe use of the equipment. The manufacturer strongly recommends that if the operator is also the owner, to read the owner's manual and thoroughly understand all instructions before using this equipment. The manufacturer also strongly recommends instructing other users to properly start and operate the unit. This prepares them if they need to operate the equipment in an emergency.

SAVE THESE INSTRUCTIONS for future reference. This manual contains important instructions for the machine that should be followed during installation, operation, and maintenance of the heater and batteries. Always supply this manual to any individual that will use this machine.

## Safety Rules

The manufacturer cannot anticipate every possible circumstance that might involve a hazard. The alerts in this manual, and on tags and decals affixed to the unit, are not all inclusive. If using a procedure, work method, or

operating technique that the manufacturer does not specifically recommend, verify that it is safe for others and does not render the equipment unsafe.

Throughout this publication, and on tags and decals affixed to the unit, DANGER, WARNING, CAUTION, and NOTE blocks are used to alert personnel to special instructions about a particular operation that may be hazardous if performed incorrectly or carelessly. Observe them carefully. Alert definitions are as follows:



Indicates a hazardous situation which, if not avoided, will result in death or serious injury.

(000001)



Indicates a hazardous situation which, if not avoided, could result in death or serious injury.

(000002)



Indicates a hazardous situation which, if not avoided, could result in minor or moderate injury.

(000003)

**NOTE:** Notes contain additional information important to a procedure and will be found within the regular text of this manual.

These safety alerts cannot eliminate the hazards that they indicate. Common sense and strict compliance with the special instructions while performing the action or service are essential to preventing accidents.

## How to Obtain Service

When the unit requires servicing or repairs, contact a GMP ASD for assistance. Service technicians are factory-trained and are capable of handling all service needs. For assistance locating a dealer, go to <https://www.generacmobileproducts.com/parts-service/find-service>.

When contacting a GMP ASD about parts and service, always supply the complete model and serial number of the unit as given on the data decal located on the unit. Record the model and serial numbers in the spaces provided on the front cover of this manual.

## General Hazards



### **⚠ DANGER**

Asphyxiation. Running engines produce carbon monoxide, a colorless, odorless, poisonous gas. Carbon monoxide, if not avoided, will result in death or serious injury.

(000103)

### **⚠ WARNING**

Personal injury. Do not operate unit during transport. Doing so could result in death, serious injury, or property damage.

(000231a)



### **⚠ WARNING**

Moving Parts. Keep clothing, hair, and appendages away from moving parts. Failure to do so could result in death or serious injury.

(000111)

### **⚠ WARNING**

Equipment damage. Do not attempt to start or operate a unit in need of repair or scheduled maintenance. Doing so could result in serious injury, death, or equipment failure or damage.

(000291)



### **⚠ WARNING**

Hot Surfaces. When operating machine, do not touch hot surfaces. Keep machine away from combustibles during use. Hot surfaces could result in severe burns or fire.

(000108)



### **⚠ WARNING**

Hearing Loss. Hearing protection is recommended when using this machine. Failure to wear hearing protection could result in permanent hearing loss.

(000107)

### **⚠ CAUTION**

Equipment or property damage. Do not block air intake or restrict proper air flow. Doing so could result in unsafe operation or damage to unit.

(000229)

### **⚠ CAUTION**

Unit damage. Do not stop engine before heating unit is cooled. Doing so could result in unit damage.

(000240a)

### **⚠ CAUTION**

Equipment Damage. The emergency stop switch is not to be used to power down the unit under normal operating circumstances. Doing so could result in equipment damage.

(000246b)

## Explosion and Fire Hazards



### **⚠ DANGER**

Explosion and Fire. Fuel and vapors are extremely flammable and explosive. Add fuel in a well ventilated area. Keep fire and spark away. Failure to do so will result in death or serious injury.

(000105)



### **⚠ DANGER**

Explosion and Fire. Do not fill fuel tank past full line. Allow for fuel expansion. Overfilling may cause fuel to spill onto engine causing fire or explosion, which will result in death or serious injury.

(000214)



### **⚠ DANGER**

Explosion and Fire. Fuel and vapors are extremely flammable and explosive. Store fuel in a well ventilated area. Keep fire and spark away. Failure to do so will result in death or serious injury.

(000143)



### **⚠ WARNING**

Risk of Fire. Unit must be positioned in a manner that prevents combustible material accumulation underneath. Failure to do so could result in death or serious injury.

(000147)



### **⚠ WARNING**

Fire risk. Fuel and vapors are extremely flammable. Do not operate indoors. Doing so could result in death, serious injury, or property or equipment damage.

(000281)



### **⚠ WARNING**

Explosion and fire risk. Do not smoke near unit. Keep fire and spark away. Failure to do so could result in death, serious injury, or property or equipment damage.

(000282)

## Trailer Hazards

### ⚠️ WARNING

Personal injury. Trailer must be securely coupled to the hitch with the chains correctly attached. Uncoupled or unchained towing could result in death or serious injury.

(000233a)

### ⚠️ WARNING

Crushing hazard. Verify unit is properly secured and on level ground. An unsecured unit can suddenly roll or move, causing death or serious injury.

(000234a)

### ⚠️ WARNING

Property or Equipment Damage. Tighten wheel lug nuts after first 50 miles to factory specifications. Failure to do so could result in death, serious injury, property or equipment damage.

(000235)

### ⚠️ WARNING

Rollover hazard. Unit must be placed on flat, level ground to prevent tipping or rollover. Failure to do so could result in death, serious injury, or property or equipment damage.

(000283)

### ⚠️ WARNING

Property or equipment damage. Do not alter the trailer. Alterations can damage essential safety items. Doing so could result in death, serious injury, or property or equipment damage.

(000285)

## Battery Hazards



### ⚠️ WARNING

Explosion. Do not dispose of batteries in a fire. Batteries are explosive. Electrolyte solution can cause burns and blindness. If electrolyte contacts skin or eyes, flush with water and seek immediate medical attention.

(000162)



### ⚠️ WARNING

Risk of burn. Do not open or mutilate batteries. Batteries contain electrolyte solution which can cause burns and blindness. If electrolyte contacts skin or eyes, flush with water and seek immediate medical attention.

(000163a)

### ⚠️ WARNING

Accidental Start-up. Disconnect the negative battery cable, then the positive battery cable when working on unit. Failure to do so could result in death or serious injury.

(000130)



### ⚠️ WARNING

Vision Loss. Eye protection is required to avoid spray from spark plug hole when cranking engine. Failure to do so could result in vision loss.

(000181)

### ⚠️ WARNING

Environmental Hazard. Always recycle batteries at an official recycling center in accordance with all local laws and regulations. Failure to do so could result in environmental damage, death, or serious injury.

(000228)

Always recycle batteries in accordance with local laws and regulations. Contact your local solid waste collection site or recycling facility to obtain information on local recycling processes. For more information on battery recycling, visit the Battery Council International website at: <http://batteryCouncil.org>

## Service Safety

### ⚠️ CAUTION

Personal injury. Wear appropriate personal protective equipment at all times while operating and servicing unit. Failure to do so could result in personal injury.

(000419)

- **DO NOT** perform even routine service (oil/filter changes, cleaning, etc.) unless all electrical components are shut down.
- Replace all missing and hard to read decals. Decals provide important operating instructions and warn of dangers and hazards.

## Towing Safety

Towing a trailer requires care. The trailer and vehicle must be in good condition and securely fastened to each other to reduce the possibility of an accident. Some states require that large trailers be registered and licensed. Contact your local Department of Transportation (DOT) office to verify license requirements for your particular unit.

## Hitch and Coupling

- Verify the hitch and coupling on the towing vehicle are rated equal to, or greater than, the trailer's Gross Vehicle Weight Rating (GVWR).
- Verify the trailer hitch and the coupling are compatible. Verify the coupling is securely fastened to the vehicle.
- **DO NOT** tow the trailer using defective parts. Inspect the hitch and coupling for wear or damage before every tow.
- To eliminate squeaking, wipe the coupler clean and apply fresh grease each time the trailer is towed.
- Connect safety chains in a crossing pattern under the tongue.
- Before towing the trailer, verify that the weight of the trailer is equal across all tires. On trailers with adjustable height hitches, adjust the angle of the trailer tongue to keep the trailer as level as possible.
- Verify all access doors on the trailer are closed and locked.

## Running Lights

- Verify directional and brake lights on trailer are connected and working properly.

## Safe Towing Techniques

- Practice turning, stopping, and backing up in an area away from heavy traffic prior to transporting the unit.
- Maximum recommended speed for highway towing is 45 mph (72 km/h). Recommended off-road towing speed is 10 mph (16 km/h) or less, depending on terrain.
- When towing, maintain extra space between vehicles and avoid soft shoulders, curbs, and sudden lane changes.
- Reduce speed before curves, and maintain speed throughout the curve.

Reduce speed before going over bumps or holes. Keep your foot off the accelerator while going over bumps or holes.

## Reporting Trailer Safety Defects

If you believe your trailer has a defect which could cause a crash, injury, or death, you should immediately inform the National Highway Traffic Safety Administration (NHTSA) in addition to notifying Generac Mobile Products, LLC.

If NHTSA receives similar complaints, it may open an investigation. If it finds that a safety defect exists in a group of vehicles, it may order a recall and remedy cam-

paign. However, NHTSA cannot become involved in an individual problem between you, your dealer, or Generac Mobile Products, LLC.

To contact NHTSA, you may either call the Auto Safety Hotline toll-free at 1-888-327-4236 (TTY:1-800-424-9153), go to <http://www.safercar.gov>, or write to:

Administrator  
NHTSA  
1200 New Jersey Avenue S.E.  
Washington, DC 20590

You can also obtain other information about motor vehicle safety from <http://www.safercar.gov>.



# Section 2: General Information

## Specifications

Description	Unit of Measure	MFH900
<b>Engine</b>		
Make (Model)	—	Perkins (1204F-E44TTA)
EPA Certification	tier	4 Final
Type	—	Diesel, liquid cooled, 4-stroke
Horsepower At Operating Speed	hp (kW)	150 (112 kW)
Operating Speed	rpm	2,200
Displacement	in <sup>3</sup> (L)	268.5 (4.4)
Cylinders	qty	4
Fuel Type	—	#1 diesel (below 32 °F [0° C]), #2 diesel
Fuel Consumption	gph (Lph)	4.9 (29.9)
DEF Consumption	gph (Lph)	0.4 (1.51)
Fan	—	Puller type, 26 in (66 cm) diameter, seven blades, 26° pitch
<b>Capacities</b>		
Minimum Run Time	hr	26
Fuel—Tank, Usable	gal (L)	200 (757.1), 178 (673.8)
DEF—Tank, Usable	gal (L)	10 (38), 8 (30)
HTF—Tank, System	gal (L)	14 (53), 20.6 (77.9 L)
Coolant	gal (L)	4.8 (18)
Oil	qt (L)	10.3 (9.75)
<b>Heater</b>		
Type	—	Flameless, self-contained
Maximum Heat Produced	BTU/hr (kW/hr)	875,000 (256.44)
Air Output—Temperature Range	°F (°C)	120–180 (48.9–82.2)
Air Output—Volume	ft <sup>3</sup> /min (m <sup>3</sup> /min)	3,500–5,000 (99.1–141.6)
Air Ducts	qty, diameter	Two, 12 in (30.5 cm)
Estimated Efficiency	%	85
HTF Pump	type	Variable displacement piston pump
<b>Trailer</b>		
Brakes	Type	Electric
Per-Axle Rating	lb (kg)	8,000 (3,628.7)
Axles	qty	1
Tire Size	—	ST215/75R15.7
Hitch	size, type	2-5/16 in, ball coupler
Maximum Tire Pressure	psi (kPa)	123 (848)
<b>Electrical</b>		
System Voltage	VDC	24
Battery—Voltage (Quantity Per Unit)	VDC (qty)	12 (2)
Battery—Rating	CCA	950
Battery—Group Number	—	31
Controller, Display	—	Epec 3610, Wachendorf OPUS A3
<b>Unit Weight</b>		
Dry	lb (kg)	6,590 (2,992)
Operating	lb (kg)	7,700 (3,512)

Specifications are subject to change without notice.

## Unit Dimensions

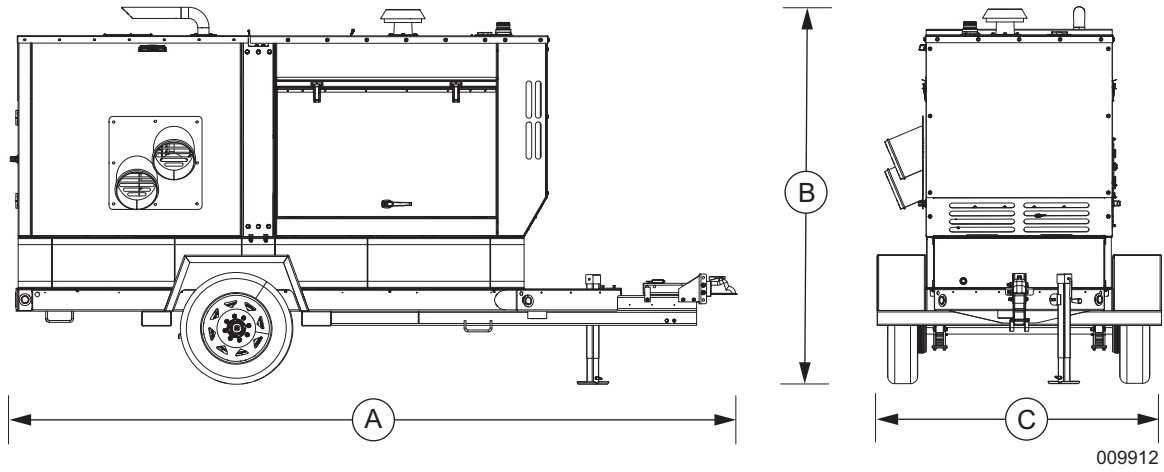

Figure 2-1. MFH900

A	B	C
192 in (4.88 m)	94 in (2.39 m)	76.5 in (1.93 m)

## Unit Serial Number Locations

See **Figure 2-2** for unit ID tag and Vehicle Identification Number (VIN) tag. Important information, such as the unit serial number, model number, VIN and tire loading information are found on these tags. Record the

information from these tags so it is available if the tags are lost or damaged. When ordering parts or requesting assistance, you may be asked to provide this information.

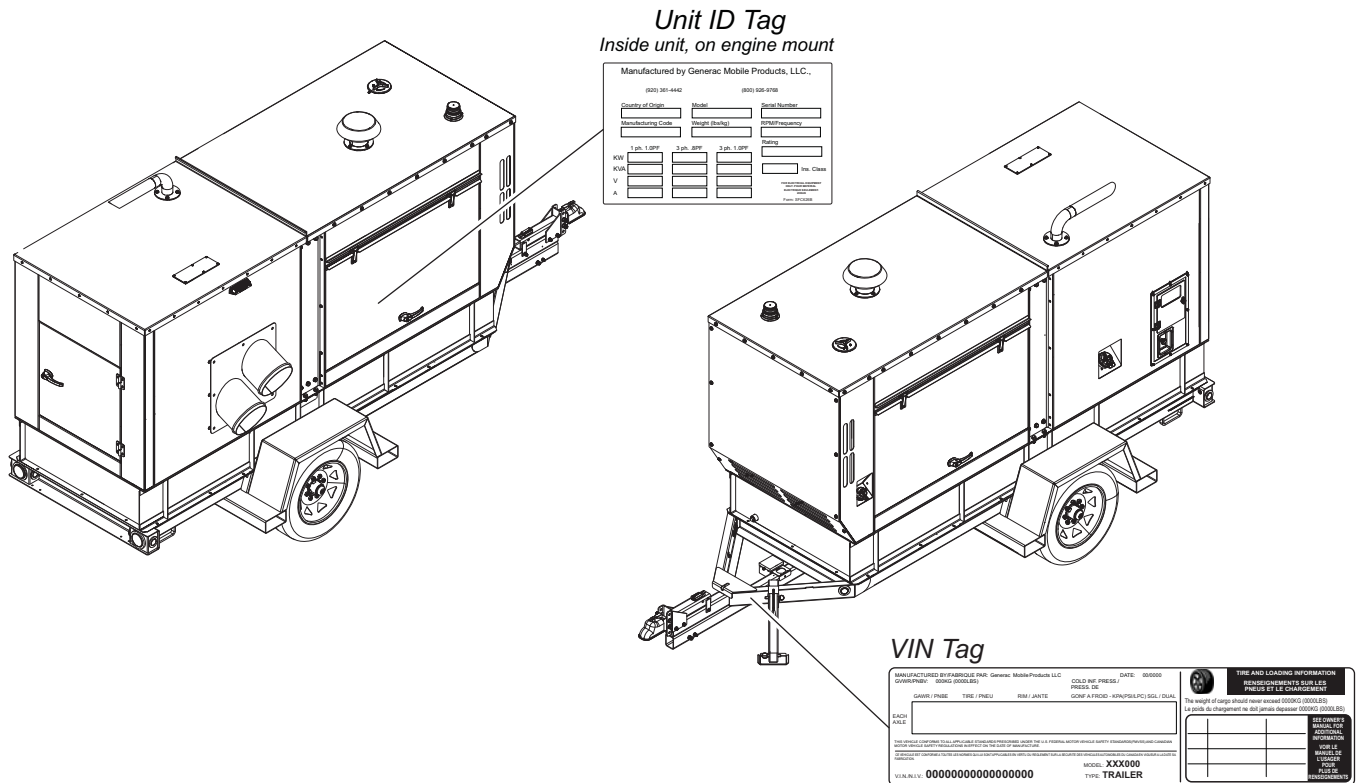
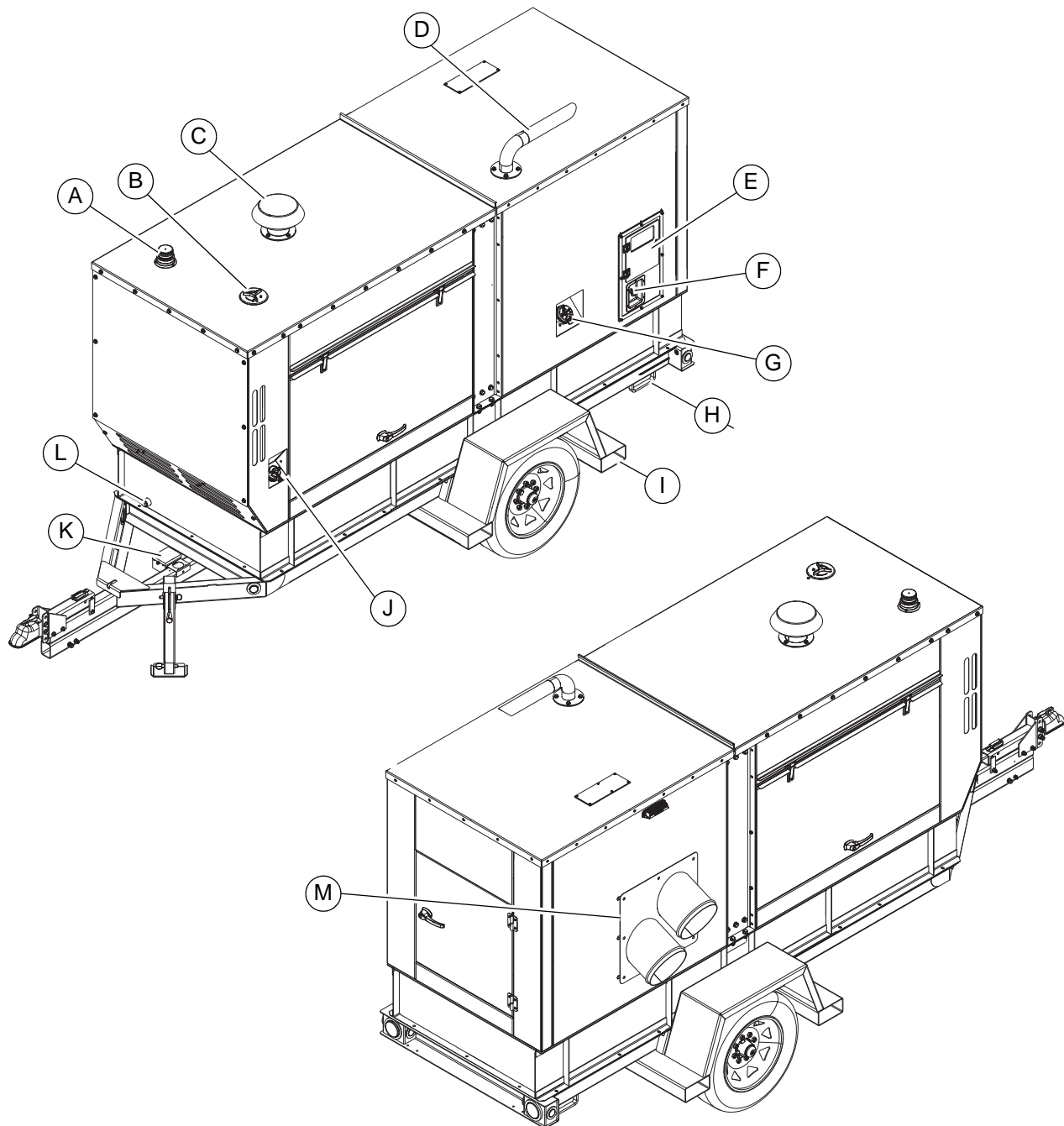

Figure 2-2. Serial Number Locations

## Component Locations

### Exterior



**Figure 2-3. Exterior Components**

- |   |                            |   |                               |
|---|----------------------------|---|-------------------------------|
| A | Roof beacon                | G | Fuel fill                     |
| B | Radiator fill access panel | H | Tie-down (4 locations)        |
| C | Air intake                 | I | Forklift pocket (4 locations) |
| D | Exhaust                    | J | DEF fill                      |
| E | Control panel              | K | Battery for breakaway brakes  |
| F | Emergency stop switch      | L | Union fluid drain port        |
|   |                            | M | Hot air discharge ducts       |

Interior

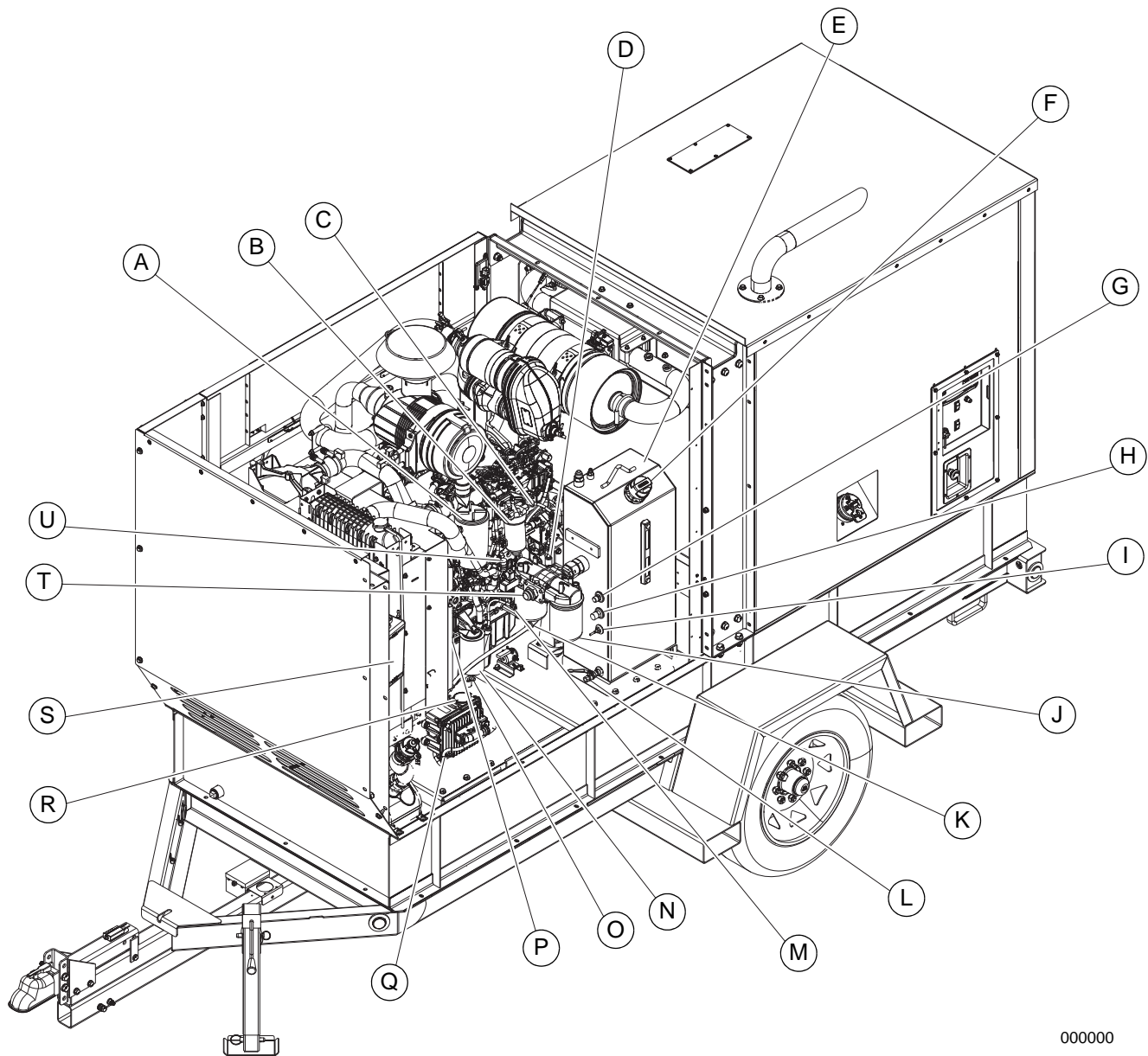

000000

**Figure 2-4. Interior Components—1 of 2**

- |  |                                      |
|--|--------------------------------------|
| A Engine crankcase filter                                | L HTF ball valve                     |
| B Secondary fuel filter                                  | M Engine oil level gauge (dipstick)  |
| C Primary fuel filter (water separator)                  | N Engine oil filter                  |
| D Fuel lift pump   | O Engine oil ball valve              |
| E Heat transfer fluid (HTF or hydraulic fluid) reservoir | P Engine oil fill                    |
| F HTF fill point and breather                            | Q DEF pump                           |
| G HTF level switch                                       | R DEF pump filter (under cap)        |
| H HTF high-temperature switch                            | S Coolant overflow tank              |
| I HTF thermistor   | T Clog sensor for HTF filters        |
| J HTF filter (2 locations)                               | U Perkins ECU engine diagnostic port |
| K Inline fuel filter                                     |                                      |

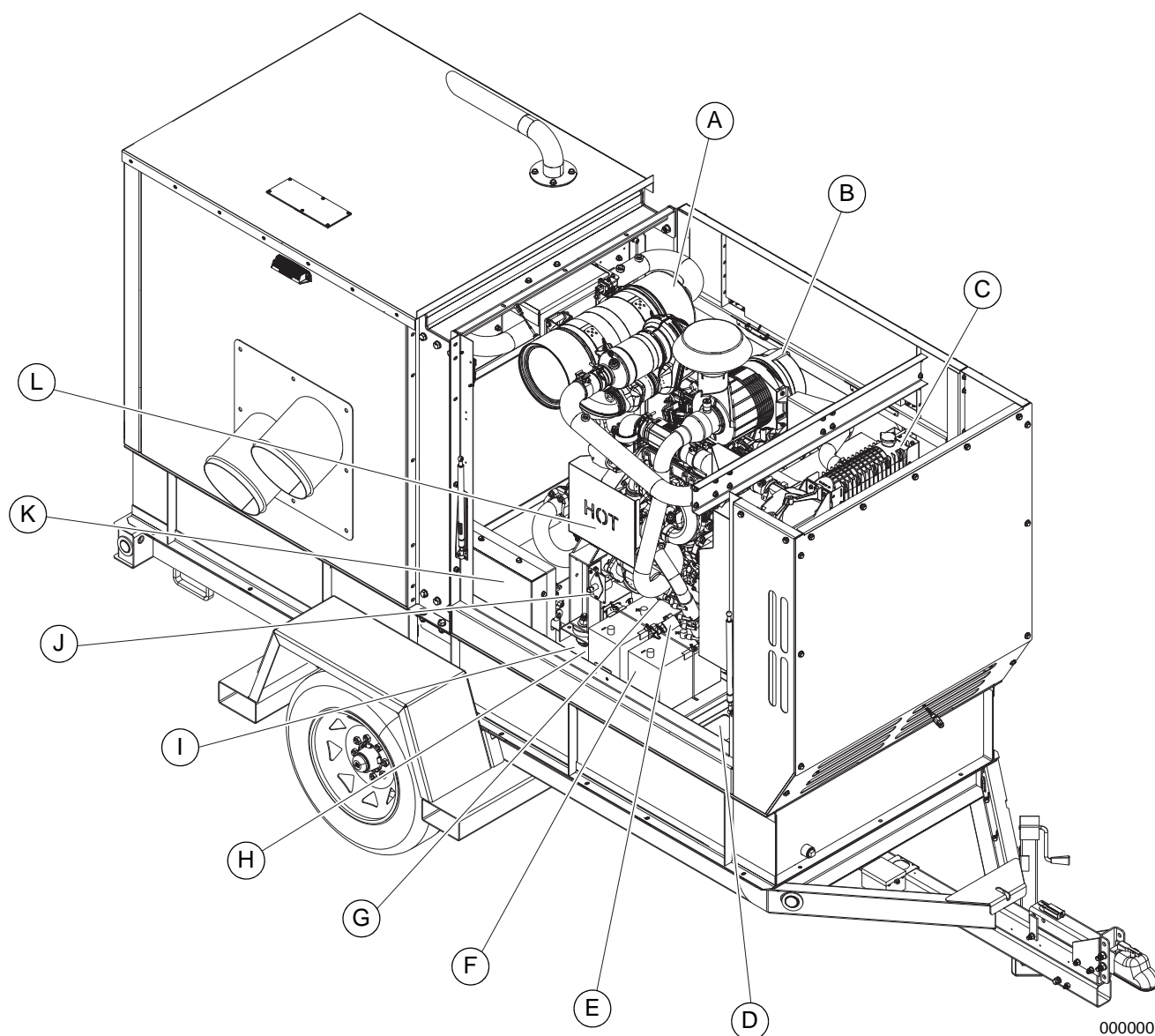

**Figure 2-5. Interior Components—2 of 2**

- |   |   |   |                                     |
|---|---|---|-------------------------------------|
| A | Selective catalytic reduction (SCR) canister  | G | Engine starter                      |
| B | Intake air filter   | H | Ground strip (on floor)             |
| C | Engine radiator   | I | Fuse block (next to ground strip)   |
| D | Union drain manifold (through hole in floor)—ball valves for DEF, coolant, and fuel | J | Battery disconnect switch           |
| E | Positive air shutdown (PAS)   | K | Hydraulic manifold (behind shield)  |
| F | Battery (2 locations)   | L | Series turbocharger (behind shield) |

## Control Panel

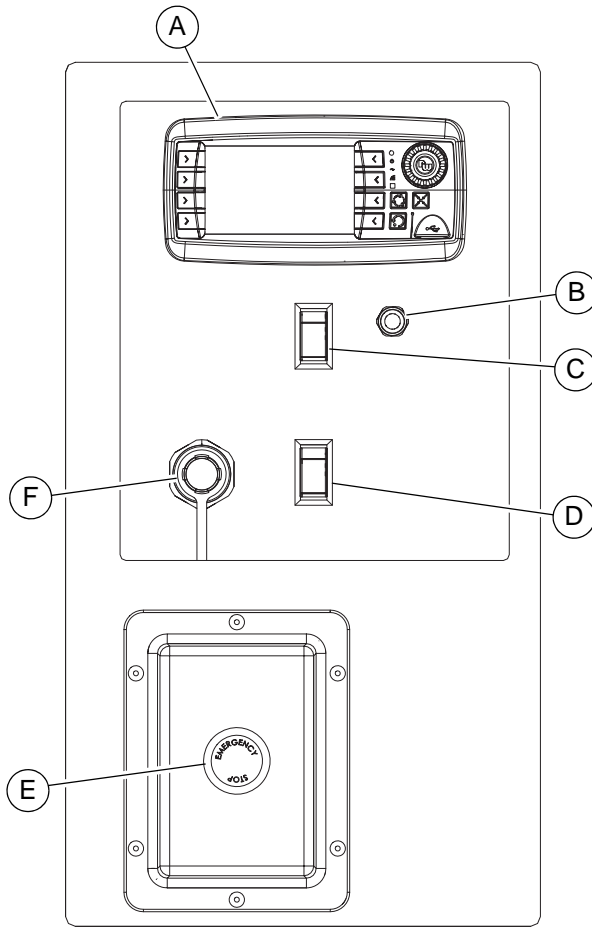

**Figure 2-6. Control Panel**

- A** Controller
- B** Unit start switch
- C** Main power switch
- D** Light switch
- E** Emergency stop switch
- F** USB port

**Controller**

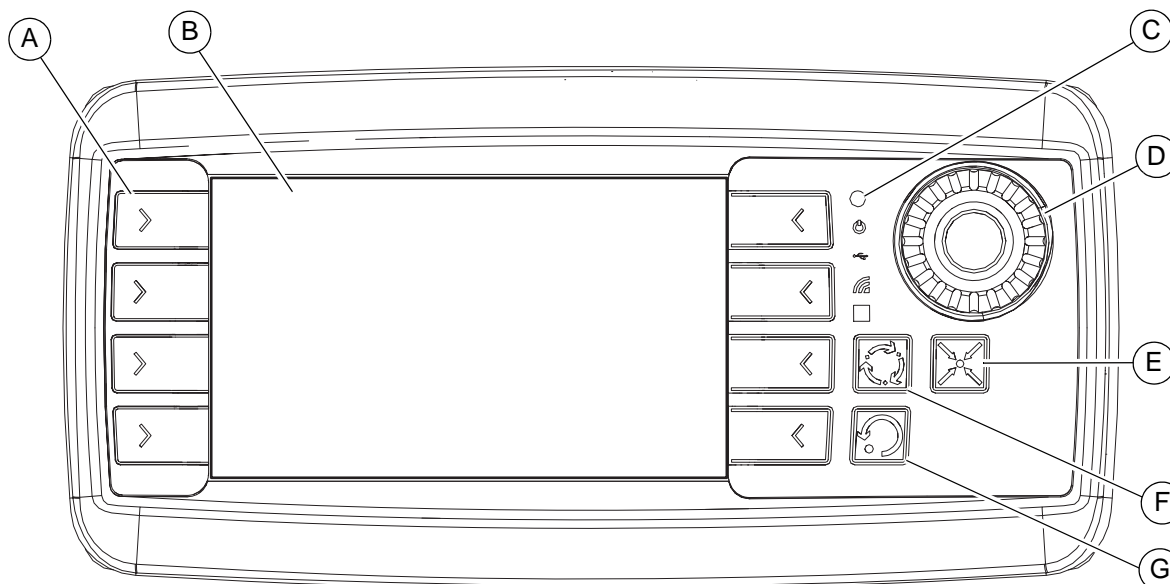

**Figure 2-7. MFH900 Controller—Common Functions**

- A** Main button (eight)  
Eight buttons around the screen are for page-to-page navigation or real-time heater adjustment. See [Figure 2-8](#). On most pages, an icon displays next to each button (A). Each icon indicates what navigation or adjustment occurs when the corresponding button is pushed.

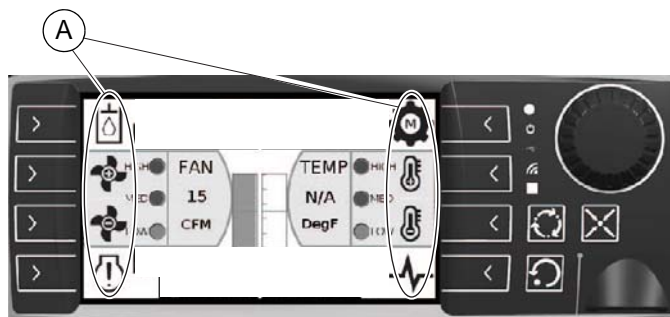

**Figure 2-8. Home Page**

More information is provided throughout this manual.

- B** Screen
- C** Faceplate icon (four)
- D** Knob  
Navigates selection on current page:
  - Twist knob: Scroll
  - Push knob: Select
- E** Go to Home page
- F** [not used]
- G** Go to previous page

## Controller Display: Alert (Icon) Definitions

See [Figure 2-9](#). The controller displays many alerts in specific areas of the controller (A). Alerts are often accompanied by explanatory text (B).

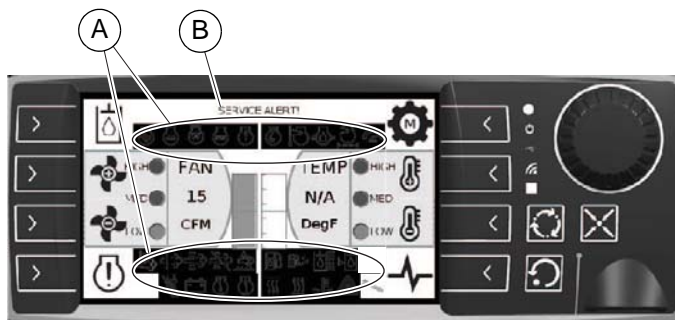

**Figure 2-9. Alerts Display**

Some alerts are routine and indicate normal unit function; others indicate problems.

### Routine Alerts

The alerts described below are routine and indicate normal unit function.

Icon	Icon ID	State	Indicated Condition
	Engine At Work Speed	Steady ON (green)	Engine is at desired work speed or higher (about 2,200 rpm or higher)
	Engine At Idle	Steady ON (green)	Engine is at idle rpm (about 800 rpm or lower)
	Wait to Start	Steady ON	Glow plugs are ON—engine is preheating
	Engine Heating	Steady ON (amber)	Engine is heating coolant to a minimum temperature
	Engine Cooling	Steady ON (blue)	Engine ECU indicates engine is cooling
	Heater Cooling	Steady ON	During unit shutdown
	Heater Heating	Steady ON	During unit shutdown
	Wait To Disconnect	Steady ON (amber)	DEF purge cycle in progress (may take up to 10 minutes) Corresponds with battery disconnect indicator light
	Delayed Engine Shutdown	Steady ON	DPF outlet temperature is above a set temperature threshold
		Steady ON (amber) and Steady ON—Engine Cooling lamp	Engine is cooling

### Warning and Fault Alerts

When a warning or fault alert displays, the unit requires inspection or service. See [Troubleshooting](#) for more information.



### Controller Faceplate Icons

See **Figure 2-6**, Four icons are stamped into the controller faceplate. They illuminate according to situation.

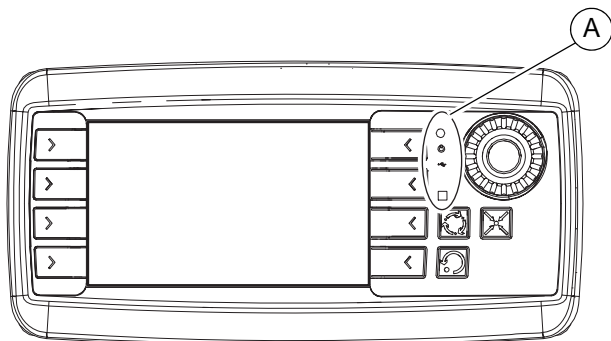

**Figure 2-10. Faceplate Icons**

Icon (Lit)	Indicates
	Photo sensor for controller display (day or night mode)
	When lit (green), controller power is ON
	When lit, USB cable is connected
	[not used]

### Emissions Information

For emissions information, see OEM engine manual.

### Engine Oil Recommendations

Genuine Generac parts are recommended for all maintenance items.

All Generac oil kits meet minimum American Petroleum Institute (API) Service Class CJ-4/SM. Select the appropriate viscosity oil grade according to the expected operating temperature. Synthetic oil also can be used in the appropriate weight as standard, once the engine has been broken in. Once synthetic oil is used, it should be used for the life of the unit. It is not recommended to go back to a mineral oil. Do not use special additives.

See **Specifications** for engine oil capacity.

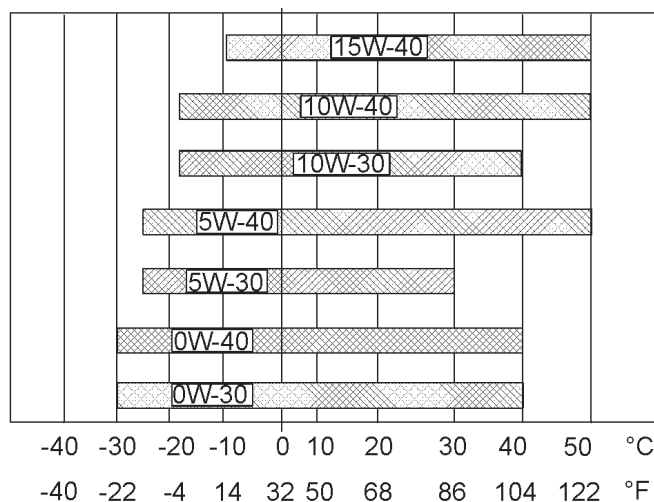

**Figure 2-11. MFH900 Engine Oil Viscosity**

**NOTE:** For temperatures below -4 °F (-20 °C), use SAE 5W-30.

For more information, see OEM engine manual.

### Coolant Recommendation



**▲ DANGER**

Risk of poisoning. Do not use mouth to siphon coolant. Doing so will result in death or serious injury.

(000149)

Where the atmospheric temperature falls below freezing, the cooling system should be drained after engine operation. To eliminate the need for repeated draining and refilling, the use of a 50/50 Ethylene glycol base antifreeze/water mix is recommended. Never exceed a 60/40 antifreeze/water mix.

**NOTE:** Recommended coolant is ZEREX™ Nitrate Free Extended Life Antifreeze/Coolant.

Freezing Point °F (°C)	3 (-16)	-13 (-25)	-31 (-35)	-58 (-50)
Coolant (% Volume)	30	40	50	60
Water (% Volume)	70	60	50	40

See **Specifications** for coolant capacity.

For more information, see OEM engine manual.

## Fuel System



### **⚠ DANGER**

Explosion and Fire. Fuel and vapors are extremely flammable and explosive. Keep fire and spark away. Failure to do so will result in death or serious injury. (000168)



### **⚠ DANGER**

Explosion and Fire. Do not overfill fuel tank. Overfilling may cause fuel to leak and ignite or explode, resulting in death or serious injury. (000204)

The heater is designed to operate with diesel fuel.

See [Specifications](#) for fuel tank capacity.

**IMPORTANT NOTE: Comply with all laws regulating the storage and handling of fuels.**

Follow these guidelines:

- Use only ultra-low-sulfur diesel fuel.
- When temperatures are at or below freezing, use No. 1D diesel fuel.
- When temperatures are above freezing, use No. 2D diesel fuel.
- In some areas of the country, climatized fuel—a mixture of 1D and 2D, may also be used.

## Hydraulic Oil



### **⚠ DANGER**

Hydraulic Fluid Injection. High-pressure, high-temperature hydraulic fluid can pierce skin and cause severe burns. Do not check for leaks with hands. Seek immediate medical attention in case of accident. Failure to protect body accordingly will result in death or serious injury. (000239)

**NOTE:** Sometimes referred to as *heat transfer fluid* or *HTF*.

Type: Thrive DTE-10 ISO VG 68 hydraulic oil

See [Specifications](#) for tank and system capacities.

## Trailer Towing Guidelines

### **⚠ WARNING**

Personal injury. Trailer must be securely coupled to the hitch with the chains correctly attached. Uncoupled or unchained towing could result in death or serious injury. (000233a)

### **⚠ WARNING**

Property or Equipment Damage. Tighten wheel lug nuts after first 50 miles to factory specifications. Failure to do so could result in death, serious injury, property or equipment damage. (000235)

Driving a vehicle with a trailer in tow is vastly different than driving the same vehicle without a trailer in tow. Consider the following:

- It takes longer to get up to speed.
- More room is needed to turn and pass.
- More distance is needed to stop.
- The driver is responsible for keeping the vehicle and trailer in control.

Before towing, verify the following:

1. The coupling, safety chains, safety brake, tires, wheels, and lights are in working order.
2. The breakaway battery is fully charged.
3. Wheel lug nuts are tightened to 85–95 ft-lbs (115–129 Nm).
4. Brake controller engages the trailer brakes before the tow vehicle brakes.

While towing, make regular stops to verify the following:

1. Coupler is secured to the hitch and locked.
2. Electrical connections are made.
3. Appropriate slack in the safety chains.
4. Appropriate slack in the breakaway switch pull-pin cable.
5. Tires are inflated to proper air pressure and no damage or unusual wear to tread or sidewalls.
6. Trailer and doors are secured and latched.

## Wheel Chock Guidelines

### **⚠ WARNING**

Crushing hazard. Verify unit is properly secured and on level ground. An unsecured unit can suddenly roll or move, causing death or serious injury. (000234a)

- Select wheel chock according to equipment type and size.
- Always use in pairs and on firm surfaces.

- Chock in direction of grade.
- Chock both sides of wheel if direction of grade is unknown.
- Use wheel chock only after parking brake is applied and tested.
- Center chocks squarely against tread of each wheel.
- Do not drive over wheel chocks.

### Rooftop Beacon

See [Figure 2-3](#). The unit is equipped with a rooftop beacon. The beacon indicates the following:

Beacon State	Definition
Off	Unit OFF or in forced shutdown due to malfunction
Strobe	Unit operational

### Home Page (Default Operator Display)

See [Figure 2-13](#). The Home page is the default operator display: Every time the unit fully starts without a shutdown fault, the Home page displays.

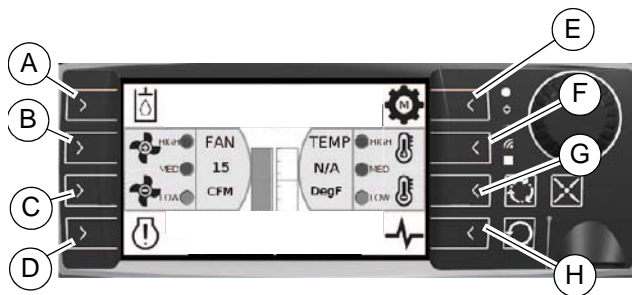

Figure 2-12. Home Page

Item	Description
A	Access Hydraulic System Information page
B	Increase airflow CFM
C	Decrease airflow CFM
D	Access Engine & Fuel Information page
E	Change mode
F	Increase air-output temperature
G	Decrease air-output temperature
H	Access Engine Diagnostics page

### Accessing Home Page from Other Pages

When the Home icon displays (A), press corresponding

button once to display Home page.

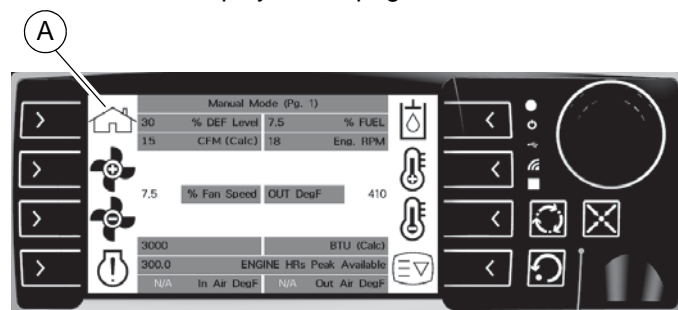

Figure 2-13. Home Icon (A) Provides Access to Home Page.

### Controller Mode

The controller has two modes—AUTO and MANUAL.

- AUTO mode is for everyday unit operation, providing basic unit functions and access to related operational information.
- MANUAL mode provides advanced functions, and is only accessible by keying a password.

**NOTE:** The unit starts in the mode in which it was last shut down.

### Changing Mode

1. See [Figure 2-14](#). When the Mode icon displays (A), press corresponding button once

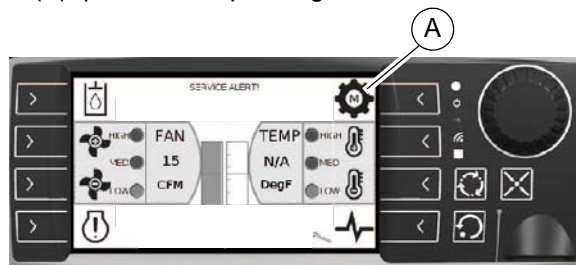

Figure 2-14. Mode Icon (A)

See [Figure 2-15](#). The Password Entry page displays.

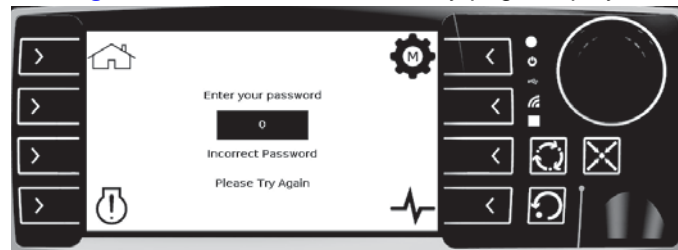

Figure 2-15. Password Entry Page

2. Enter the password.

**IMPORTANT NOTE:** Contact Generac Mobile Technical Service for password.

**About AUTO Mode**

In AUTO Mode, three temperatures are available. At each temperature, three airflow volumes are available. See table below.

Setting	Temperature—°F (°C)	Airflow—CFM
Low	120 (48.9)	Low: 4,630 Med: 4,770 High: 4,920
Med	150 (65.6)	Low: 4,050 Med: 4,170 High: 4,280
High	180 (82.2)	Low: 3,660 Med: 3,760 High: 3,860

**AUTO Mode Navigation**

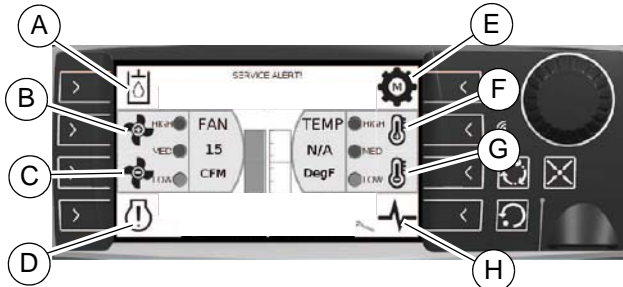

Figure 2-16. AUTO Mode Home Page

Item	Description
A	Access Hydraulic System Information page
B	Increase airflow volume
C	Decrease airflow volume
D	Access Engine & Fuel Information page
E	Change mode
F	Increase air-output temperature
G	Decrease air-output temperature
H	Access Engine Diagnostics page

**About MANUAL Mode**

In MANUAL mode, temperature is adjustable by single degrees (F) and blower speed is adjustable by single CFM. See [Specifications](#) for ranges.

MANUAL mode provides advanced access to maintain, diagnose, and troubleshoot the unit. A password is required to access MANUAL mode.

**MANUAL Mode Navigation**

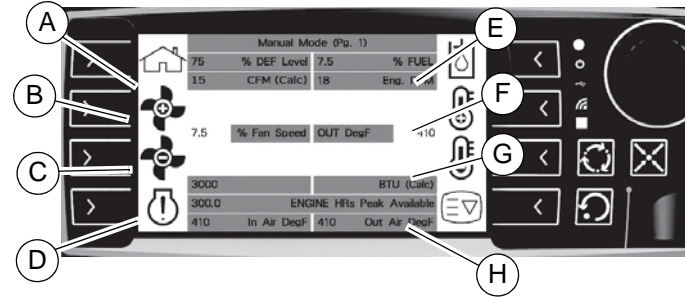

Figure 2-17. Manual Mode Home Page (1 of 2)

Function	Description
A	Go to Home page
B	Increase heater CFM
C	Decrease heater CFM
D	Go to Engine & Fuel Information page
E	Go to Hydraulic System Information page
F	Increase air-output temperature
G	Decrease air-output temperature
H	Scroll to next page

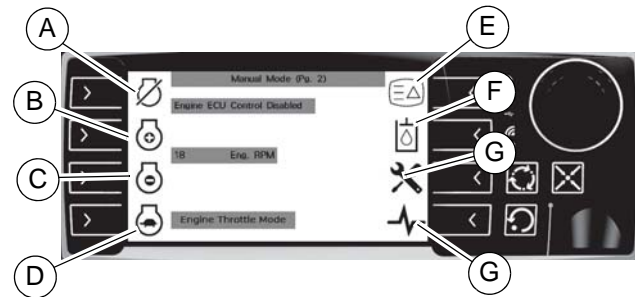

Figure 2-18. Manual Mode Home Page (2 of 2)

Function	Description
A	Go to Home page
B	Increase engine throttle
C	Decrease engine throttle
D	Adjust throttle to idle speed
E	Scroll to previous page
F	Go to Hydraulic System Information page
G	Go to parameters (password protected)
H	Go to Engine Diagnostics page

See [Advanced Controller Functions](#) for more information.

## Controller Monitoring, Diagnostic, and Protective Features

Mechanical and electrical systems are connected to various sensors that monitor unit status. If conditions occur outside of predetermined manufacturing parameters, the controller will automatically stop the machine and display fault information. The controller can also display a variety of critical alerts, diagnostics, and recommendations. The controller provides a variety of real-time current operating condition data on outlet temperature, engine rpm, and fuel level. For more information, refer to the controller wiring diagrams.

### Accessing Engine Diagnostics Page

This procedure accesses MANUAL mode. A password is required for this procedure.

1. See [Figure 2-19](#). Access a page displaying the Diagnostics icon (A).

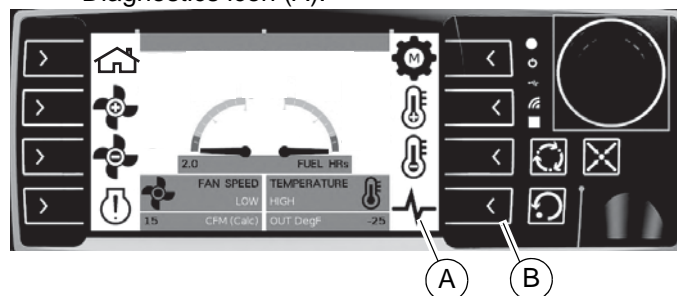

Figure 2-19. Accessing Engine Diagnostics

2. Press the Diagnostics button (B).
3. See [Figure 2-20](#). The Password Prompt page displays. Press the Diagnostics button (A).

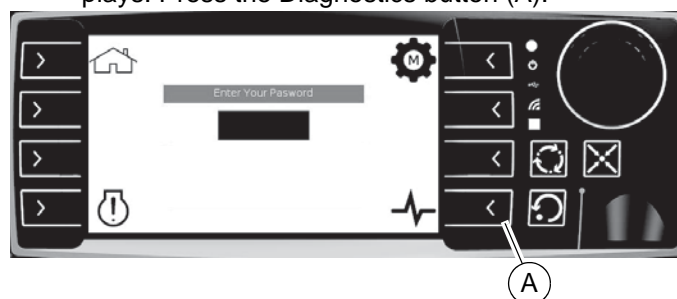

Figure 2-20. Password Prompt Page

4. See [Figure 2-21](#). The Password Entry page displays. Enter the password.

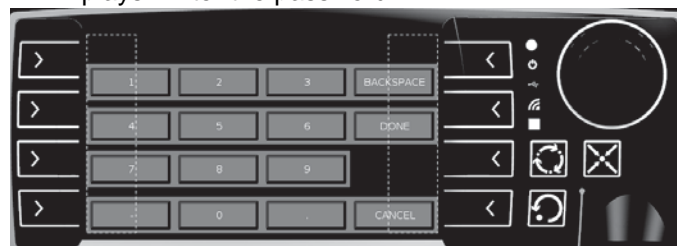

Figure 2-21. Password Entry Page

**NOTE:** To enter password: Twist knob to scroll through on-screen items. When the desired number is highlighted, press knob. Repeat until all numbers are entered. Then, scroll to DONE and press the knob.

### Using Engine Diagnostics Page

See [Figure 2-22](#). The Engine Diagnostics page:

- Displays warnings and faults.
- Provides access to detailed functional information and display brightness/contrast.

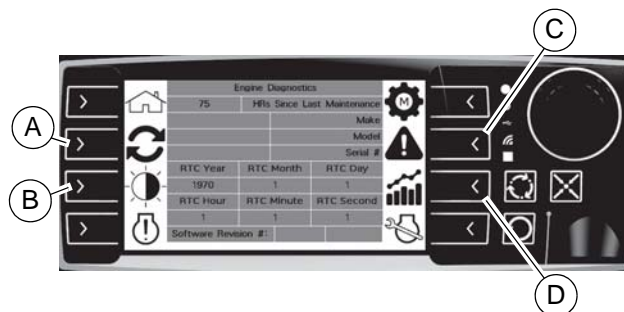

Figure 2-22. Engine Diagnostics Page

Item	Definition
A	Reset Service Interval button
B	Go to Controller Brightness/Contrast page
C	Faults button
D	Data Logging button

### Reset Service Interval (A)

Press the Reset Service Interval button to reset *HRs Since Last Maintenance* ([Figure 2-22](#)).

### Controller Brightness/Contrast (B)

Press the Controller Brightness Contrast button (B) to access controller display preferences.

### Faults (C)

Press the Faults button (C) to access fault codes and alerts.

See [Figure 2-23](#). The Enter Password page displays.

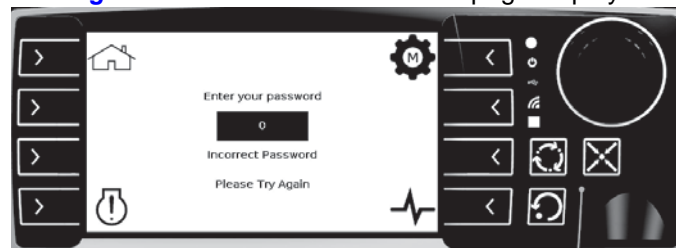
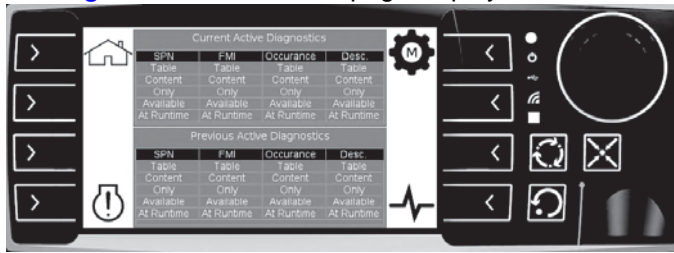

Figure 2-23. Enter Password Page

5. Enter the password.

See [Figure 2-24](#). The Faults page displays.



**Figure 2-24. Faults Page**

**NOTE:** For more information, see [Troubleshooting](#).

**Data Logging (D)**

Press this button to display engine errors and other codes. See the engine manual for more information.

**Accessing Engine and Fuel Information**

See [Figure 2-25](#). When the Engine and Fuel icon displays (A), press corresponding button once.

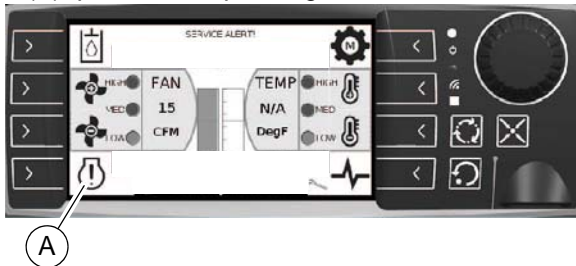

**Figure 2-25. Engine and Fuel Icon (A)**

See [Figure 2-26](#). The Engine & Fuel Information page displays.

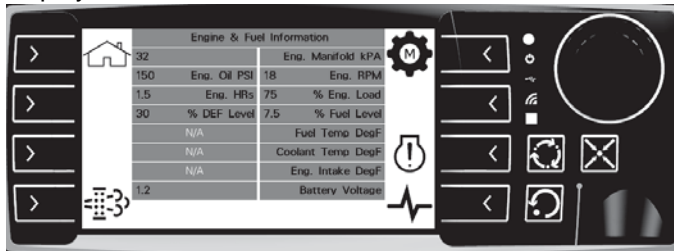

**Figure 2-26. Engine & Fuel Page**

**Advanced Controller Functions**

Advanced controller functions are only available in MANUAL mode. A password is required.

To access an advanced controller function:

1. Change controller mode to MANUAL. See [Controller Mode](#).

See [Figure 2-27](#). The Home page (1 of 2) for MANUAL mode displays.

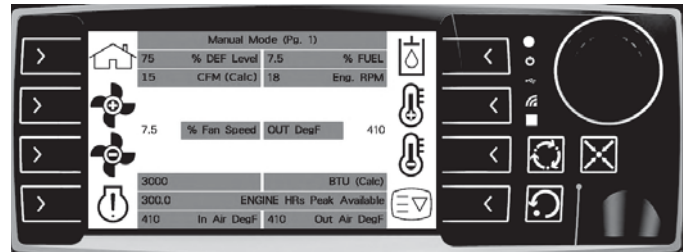

**Figure 2-27. Home Page (1 of 2)**

2. Choose a function or setting.

**Hydraulic System Information**

The Hydraulic System Information page displays hydraulic system data—HTF temperature, HTF pressure, and electrical current. To access:

1. From the Home page (1 of 2), press the Hydraulic System Information button (A).

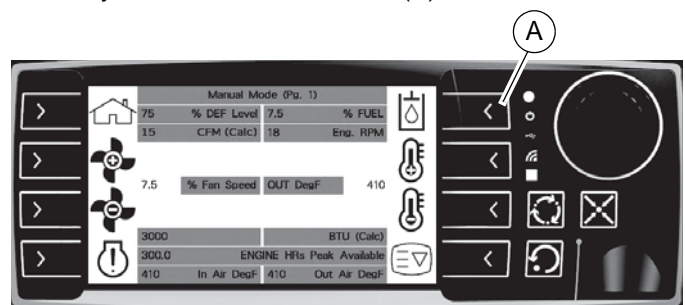

**Figure 2-28. Hydraulic System Information Button**

See [Figure 2-29](#). The Hydraulic System Information page (1 of 2) displays.

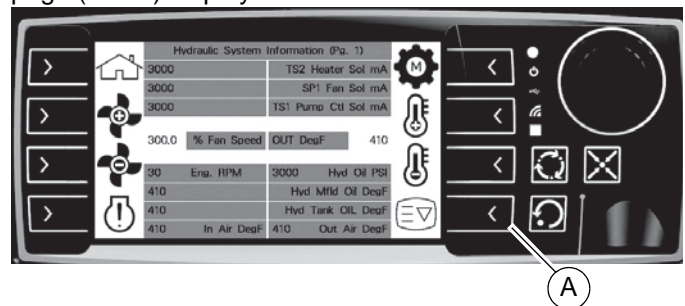

**Figure 2-29. Hydraulic System Information Page (1 of 2)**

2. Press the scroll button (A). See [Figure 2-30](#). Page 2 displays.

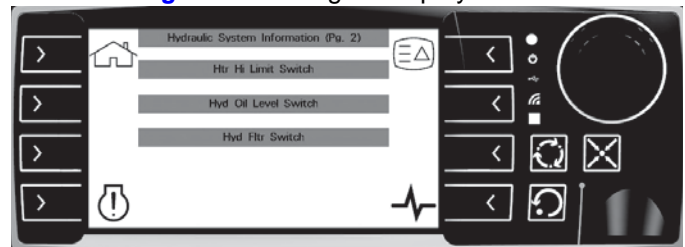

**Figure 2-30. Hydraulic System Info Page (2 of 2)**

# Section 3: Operation

## Before Starting Engine

### Pre-start Checklist



#### **WARNING**

Hot Surfaces. When operating machine, do not touch hot surfaces. Keep machine away from combustibles during use. Hot surfaces could result in severe burns or fire.

(000108)

- Verify all maintenance procedures are up to date. For more information, see [Maintenance](#).
- Verify unit is not leaking fluids: check inside and outside the unit for leaking fuel, engine oil, HTF, DEF, and engine coolant.
- Check levels of fuel, HTF, DEF, engine oil, and engine coolant.
- Remove all flammable materials and fire hazards within 5 ft (1.5 m) of heater.
- Keep heater a minimum of 5 ft (1.5 m) from structures or barricades.
- Verify the following are clear of debris and obstructions:
  - Engine air intake
  - Unit intake
  - Exhaust stack
  - Outlets and fan intakes
- Verify unit is properly secure with jacks deployed, if applicable, wheels chocked and level.
- Check alternator drive belt for tension and wear.
- Verify the emergency stop switch is pulled out

### Engine Oil Check

#### **CAUTION**

Engine damage. Verify proper type and quantity of engine oil prior to starting engine. Failure to do so could result in engine damage.

(000135)

1. Remove oil dipstick from crankcase and wipe it clean.
2. Insert oil dipstick fully and remove slowly.
3. Oil level must be between the FULL and ADD marks on the oil dipstick.

### Hydraulic Oil Check

On the hydraulic fluid reservoir tank is a gauge showing hydraulic oil level. Verify level is between MIN and MAX.

### Engine Coolant Check



#### **WARNING**

Risk of burns. Do not open coolant system until engine has completely cooled. Doing so could result in serious injury.

(000154)

1. Remove radiator fill cap.
2. Check coolant level and degree of fouling.

**NOTE:** Coolant level should be approximately 0.4 in (10.2 mm) below the radiator core top.

3. Install radiator cap securely.

### Battery Check



#### **WARNING**

Electrical shock. Disconnect battery ground terminal before working on battery or battery wires. Failure to do so could result in death or serious injury.

(000164)



#### **WARNING**

Risk of burn. Do not open or mutilate batteries. Batteries contain electrolyte solution which can cause burns and blindness. If electrolyte contacts skin or eyes, flush with water and seek immediate medical attention.

(000163a)



#### **WARNING**

Explosion. Batteries emit explosive gases while charging. Keep fire and spark away. Wear protective gear when working with batteries. Failure to do so could result in death or serious injury.

(000137a)



#### **CAUTION**

Equipment damage. Do not make battery connections in reverse. Doing so will result in equipment damage.

(000167a)

**IMPORTANT NOTE: Verify battery cable connections are not loose or corroded.**

## Starting Engine and Heater

This section applies both to MANUAL and AUTO modes.

**NOTE:** The unit starts in the mode in which it was last shut down.

1. Perform **Pre-start Checklist**.
2. Close all doors.
3. Switch PAS to OFF (O).

**NOTE:** See **Figure 2-5** for location of PAS and battery disconnect switch.

4. Switch battery disconnect to ON (I).
5. Attach ducting to unit.
6. On control panel, switch MAIN POWER to ON (I).
7. See **Figure 3-1**. Wait for controller to display **OK To Crank Engine (A)**.

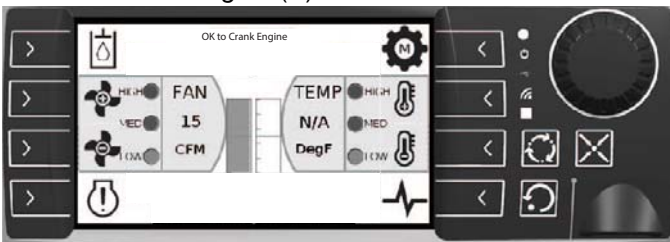

**Figure 3-1. OK to Crank Engine**

8. On control panel, press PUSH TO START button.



Equipment Damage. Do not continuously crank engine for more than ten seconds. Doing so will lead to overdischarge of batteries and starter seizure.

(000230)

Unit engine starts and begins HTF warm-up. During HTF warm-up, controller displays **Wait – Heater Warming (Figure 3-2)**.

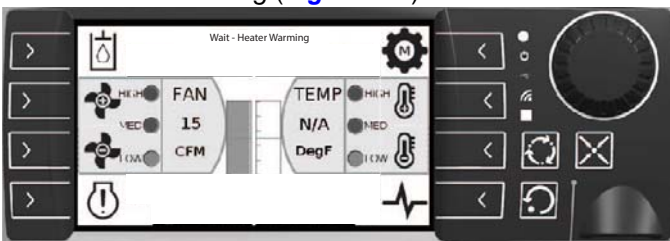

**Figure 3-2. HTF Warm-Up**

9. See **Figure 3-3**. Wait for controller to display **Heater Run**.

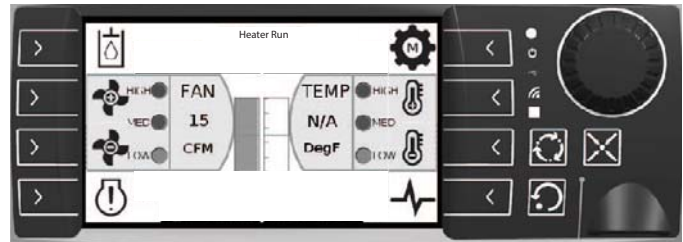

**Figure 3-3. Heater Run**

10. Adjust air output temperature and heater CFM.

## Adjusting Air Output Temperature

This section applies both to MANUAL and AUTO modes.

1. Verify unit is fully operational—controller must display **Heater Run**.
2. See **Figure 3-4**. Adjust temperature by pressing **Increase (A)** or **Decrease (B)**.

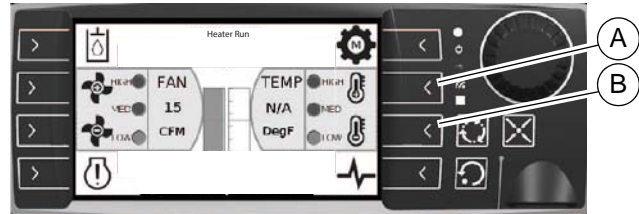

**Figure 3-4. Air Output Temperature Adjustment**

- In AUTO mode, choose one of three temperatures—120, 150, or 180 °F.
- In MANUAL mode, choose any output temperature between 120 and 180 °F.



## Adjusting Heater CFM

This section applies both to MANUAL and AUTO modes.

1. Verify unit is fully started—controller must display *Heater Run*.
2. See [Figure 3-5](#). Adjust heater CFM by pressing *Increase* (A) or *Decrease* (B).

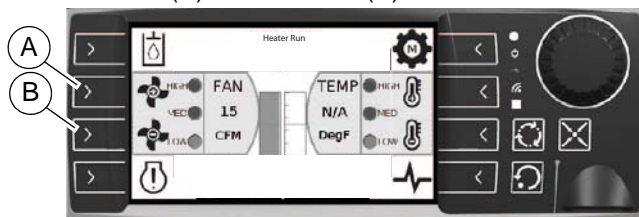

**Figure 3-5. Heater CFM Adjustment**

- In AUTO mode, choose Low, Medium, or High.

**NOTE:** In AUTO mode, selected temperature determines what heater CFM setpoints are available. See [About AUTO Mode](#) for more information.

- In MANUAL mode, choose any CFM between 2,800 and 4,900.

## Changing Controller Mode

See [Figure 3-6](#). The Mode icon (A) displays on various pages. When it displays, change controller mode by pressing corresponding button once.

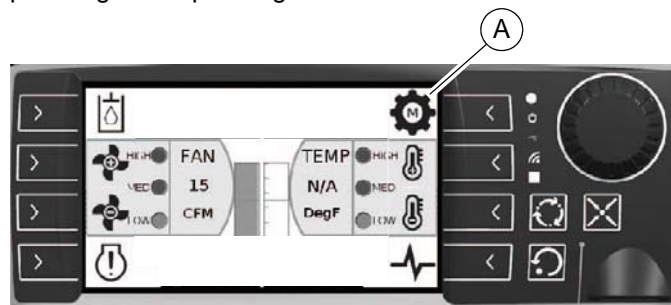

**Figure 3-6. Mode Icon**

## Shutting Down Engine and Heater

1. Switch main power to OFF (O).  
Engine runs until heat exchangers are cooled.
2. When engine stops, disconnect and stow ducting.
3. When amber light on battery disconnect switch shuts off, switch battery disconnect to OFF (O).
4. Pull (detach) the battery disconnect lever from battery disconnect switch.

**NOTE:** See [Figure 3-7](#). While the amber light is on, the Wait to Disconnect icon displays on the controller.



**Figure 3-7. Wait to Disconnect Icon**

**IMPORTANT NOTE:** Do not switch battery disconnect OFF (O) until amber light switches off. The light indicates DEF is being purged from the DEF lines. Purging the lines (the *purge cycle*) prevents DEF freezing in the lines.

**NOTE:** The purge cycle lasts up to 10 minutes.

## Emergency Stop Switch



Equipment Damage. The emergency stop switch is not to be used to power down the unit under normal operating circumstances. Doing so could result in equipment damage. (000246b)

See **Figure 3-8**. The unit is equipped with one emergency stop switch. The red button is clearly labeled EMERGENCY STOP. The switch can be accessed and activated with all doors closed and locked.

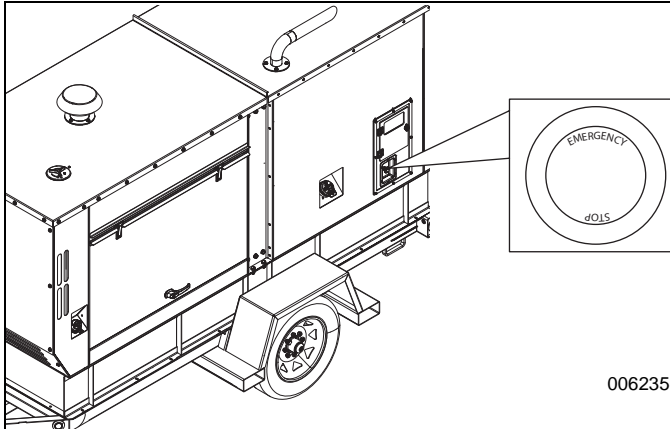

**Figure 3-8. Emergency Stop Switch**

Activate the emergency stop switch by pushing the button in until it locks down. This trips the main circuit breaker which then opens the contact, disconnecting the load to the connection lugs. This will also open the fuel circuit, shutting down the engine. The emergency stop fault will be displayed on the control panel. The switch will remain closed until it is pulled out.

## Battery Disconnect Switch

When switching OFF the battery disconnect switch:

1. Switch to the OFF position.
2. Remove the lever from the switch.

## Before Towing Unit

Before towing unit:

- Drain any fluids from containment.
- Close and lock all doors.
- Verify tire pressure.

# Section 4: Maintenance

---

**NOTE:** Normal maintenance, service, and replacement of parts are the responsibility of the owner and are not considered defects in materials or workmanship within the terms of the warranty. It is strongly recommended that equipment be periodically checked by an IASD.

## Maintenance Tasks

Daily checks must be performed when unit is operated continuously for extended periods of time. Daily checks and routine monthly checks can be performed by an authorized operator.

### Daily Walk Around Inspection

See [Maintenance Schedule](#) for additional daily tasks.

Look for conditions that could hinder performance or safety, such as (but not limited to) oil, coolant, or fuel leakage, blocked vents, loose or missing hardware, and improper electrical connections. Check for foreign matter blocking the vents and on top of unit.

- Inspect engine air cleaner service indicator
- Inspect outer cover for significant damage beyond scuffs and small nicks.
- Inspect for wire abrasion.
- Inspect the fan belt for cracks, fraying, and stretching. Verify belt is properly seated in the pulley grooves. Every 750 hours, it is recommended that the belt be removed and checked for wear. While belt is removed, inspect pulleys and bearing. Rotate and feel for hard turning or unusual sounds.
- Check coolant.
- Check electrical connectors, battery, and ground points. Look for loose or missing hardware.
- Check all flexible rubber hoses for deterioration.
- Check hydraulic hoses for signs of wear.
- Verify hoses are not crushed, kinked or twisted.
- Verify there are no cracks or corrosion.

### Checking Engine Oil Level



Engine damage. Verify proper type and quantity of engine oil prior to starting engine. Failure to do so could result in engine damage.

(000135)

**NOTE:** If engine was running, wait at least ten minutes before proceeding.

1. Remove oil dipstick and wipe it dry with a clean, lint free cloth.

2. Slowly insert the clean oil dipstick into the tube. Verify the oil dipstick is fully seated in the oil dipstick tube.
3. After 10 seconds, remove the oil dipstick and look at the oil level on both sides. The lower of the two readings will be the correct oil level measurement.
4. Add oil (if necessary) to adjust the level. After adding or changing the oil, the engine should run for one minute before checking the oil level. Wait ten minutes to allow the engine to cool and oil to fully drain into the oil pan.

Typical causes of inaccurate oil level readings:

- Reading the high level of the dipstick.
- Reading the dipstick before the oil fully drains into the oil pan.
- Inserting and removing the dipstick too quickly.
- The dipstick is not fully seated in the dipstick tube.

## Draining Fluids—Union Fluid Drain

See [Figure 4-1](#). This unit is equipped with a *union fluid drain* (A), an exterior drain port for multiple fluids—engine oil, engine fuel, engine coolant, hydraulic oil, and DEF.

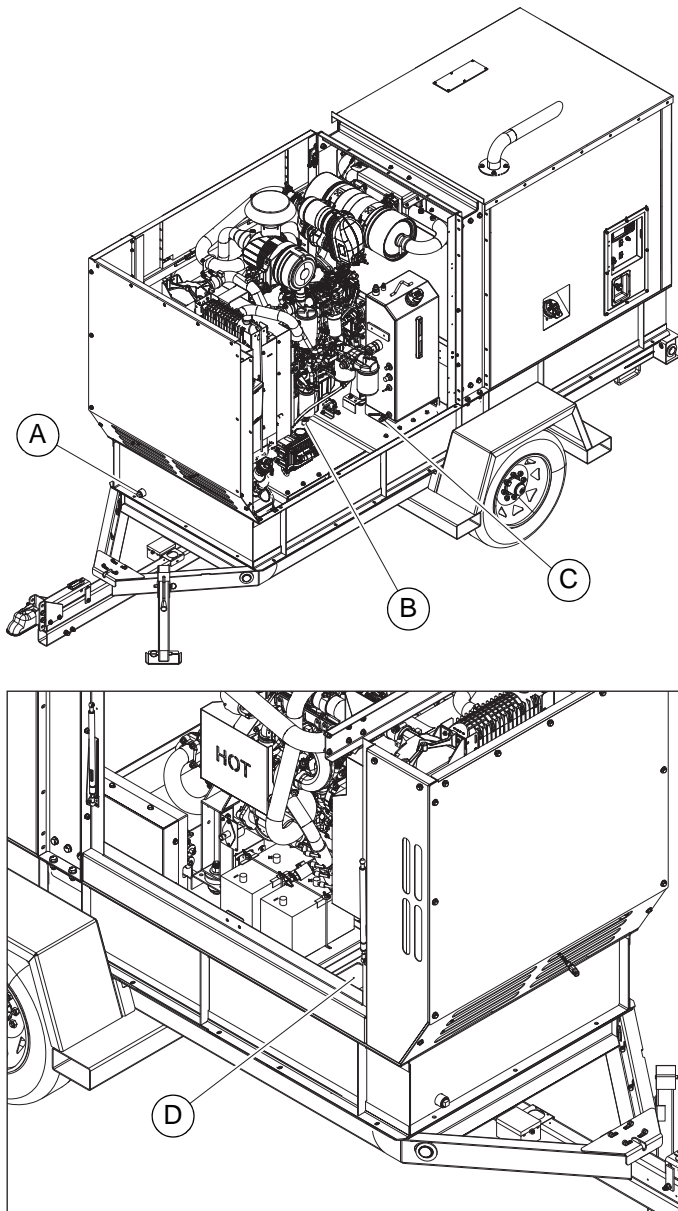

Figure 4-1.

Several ball valves (B, C, D) control fluid flows to exterior drain.

- A Union fluid drain (exterior drain port)
- B Ball valve—engine oil
- C Ball valve—hydraulic oil
- D Three ball valves—DEF, coolant, and fuel—see hole in floor

To drain a fluid:

**IMPORTANT NOTE: Drain one fluid at a time.**



**WARNING**

Risk of burns. Allow engine to cool before draining oil or coolant. Failure to do so could result in death or serious injury.

(000139)

**WARNING**

Potential of cancer. Prolonged or repeated contact with used motor oil has been shown to cause cancer in laboratory animals. Thoroughly wash exposed areas with soap and water.

(000127a)

1. Verify unit is off and interior components are cool.
2. Verify all ball valves are OFF.
3. Place suitable container under exterior drain.
4. Remove plug from exterior drain port.
5. Open a ball valve.

**IMPORTANT NOTE: Drain one fluid at a time—do not open more than one ball valve.**

6. Allow fluid to drain.
7. When fluid stops flowing from exterior drain, install exterior drain plug removed in step 4.
8. On the controller, reset the service interval. See [Accessing and Resetting Controller Service Intervals](#) for more information.

## Adding Coolant



**DANGER**

Risk of poisoning. Do not use mouth to siphon coolant. Doing so will result in death or serious injury.

(000149)



**WARNING**

Risk of burns. Do not open coolant system until engine has completely cooled. Doing so could result in serious injury.

(000154)

**CAUTION**

Risk of overheating. Do not use any chromate base rust inhibitor with propylene glycol base antifreeze, boosters, or additives. Doing so will cause overheating and possible equipment damage.

(000165a)

If coolant level is below the filler neck, coolant needs to be added (see [Coolant Recommendation](#)).

1. Verify engine is stopped and cooled.

2. Remove radiator cap.
3. Fill radiator slowly with coolant until it comes up to the filler neck.
4. Operate engine approximately five minutes at a low idle speed to bleed the air in the coolant circuit.

**NOTE:** Coolant level will drop.

5. Stop the engine and, once cooled, replenish with coolant.

### **Removing Crankcase Filter**

To remove crankcase filter, unscrew top and lift vertically.

**NOTE:** Removal may be difficult due to suction.

See engine manual for more information.

### **Engine Diagnostic Port and ECM (Engine Control Module)**

See engine manual.

## Maintenance Schedule

Periodic inspection, service, and maintenance of this unit is critical to ensure reliable operation. The following is the manufacturer's recommended maintenance schedule. The maintenance items will need to be performed more frequently if the heater is used in severe applications (such as very high or very low ambient conditions or extremely dirty/dusty environments). Use the heater hour meter or calendar time, whichever occurs first, from the previous maintenance interval to determine the next required maintenance interval. Note that some checks are based on hours of operation.

Follow all applicable safety alerts found in this manual or engine service manual before performing any maintenance checks or service.

This maintenance schedule reflects the minimum tasks that need to be accomplished to verify the heater remains operational. Some of the tasks can be performed by an authorized operator and others must be performed by an IASD.

**NOTE:** An authorized operator is one who has been trained by an IASD in proper operation and inspection of this unit.

### Engine Maintenance Schedule

For procedures, see the OEM engine manual.

Daily	<ul style="list-style-type: none"> <li>• Check coolant level</li> <li>• Check driven equipment</li> <li>• Inspect engine air cleaner service indicator</li> <li>• Check/clean engine air precleaner</li> <li>• Check engine oil level</li> <li>• Drain fuel system primary filter/water separator</li> <li>• Walk-around inspection</li> </ul>
Weekly	<ul style="list-style-type: none"> <li>• Inspect/replace hoses and clamps</li> </ul>
Every 50 hr or weekly	<ul style="list-style-type: none"> <li>• Drain fuel tank water and sediment</li> </ul>
Every 250 hr	<ul style="list-style-type: none"> <li>• Replace fuel filter elements*—inline filter, primary filter, and secondary filter</li> </ul>
Every 500 hr	<ul style="list-style-type: none"> <li>• Check fan clearance</li> </ul>
Every 500 hr or 1 yr	<ul style="list-style-type: none"> <li>• Check battery electrolyte level</li> <li>• Inspect/clean/replace engine air cleaner element (dual element)</li> <li>• Inspect/replace engine air cleaner element (single element)</li> <li>• Change engine oil and filter</li> <li>• Replace inline fuel filter</li> <li>• Replace fuel system primary filter (water separator) element</li> <li>• Replace fuel system secondary filter</li> <li>• Clean radiator</li> </ul>
Every 1,000 hr	<ul style="list-style-type: none"> <li>• Inspect belt</li> <li>• Check belt tensioner</li> <li>• Inspect water pump</li> <li>• Change hydraulic oil and filter</li> </ul>
Every 1,500 hr	<ul style="list-style-type: none"> <li>• Clean/replace diesel exhaust fluid filter</li> <li>• Replace engine crankcase breather element</li> </ul>
Every 2,000 hr	<ul style="list-style-type: none"> <li>• Inspect aftercooler core</li> <li>• Inspect alternator</li> <li>• Inspect clean-emissions module support</li> <li>• Inspect engine mounts</li> <li>• Inspect starting motor</li> <li>• Inspect turbocharger</li> </ul>
Every 3,000 hr	<ul style="list-style-type: none"> <li>• Replace alternator and fan belts</li> </ul>
Every 3,000 hr or 2 yr	<ul style="list-style-type: none"> <li>• Change coolant (DEAC)</li> </ul>

Every 4,000 hr	<ul style="list-style-type: none"> <li>• Clean/test aftercooler core</li> </ul>
Every 4,500 hr or 3 yr	<ul style="list-style-type: none"> <li>• Change DEF dosing unit filter</li> </ul>
Every 6,000 hr or 3 yr	<ul style="list-style-type: none"> <li>• Add coolant extender (ELC)</li> </ul>
Every 10,000 hr	<ul style="list-style-type: none"> <li>• Replace DEF manifold filters</li> </ul>
Every 12,000 hr or 6 yr	<ul style="list-style-type: none"> <li>• Change coolant (ELC)</li> </ul>
Commissioning	<ul style="list-style-type: none"> <li>• Check fan clearance</li> </ul>
As required	<ul style="list-style-type: none"> <li>• Clean DEF tank</li> <li>• Fill DEF tank</li> <li>• Flush DEF tank</li> <li>• Clean engine</li> <li>• Inspect/replace engine air cleaner element (dual element)</li> <li>• Inspect/replace engine air cleaner element (single element)</li> <li>• Replace battery</li> <li>• Prime fuel system</li> <li>• Obtain engine oil sample</li> </ul>

**NOTE:** All service and maintenance or repairs are recommended to be completed by an IASD to maintain the warranty status of a unit. You cannot be denied emissions warranty coverage solely based on failure to complete recommended service maintenance.

**NOTE:** For additional maintenance information, see engine manual.

### Hydraulic Oil Schedule

The hydraulic oil change schedule is:

1. Change every 1,000 hr and
2. Change at the end of the season.

### Hydraulic Oil Filters Schedule

The hydraulic oil filters should be changed on each of the following occasions:

- When changing hydraulic oil
- When hydraulic oil filters are clogged. See [Figure 4-2](#). When filters are clogged, The controller displays the illustrated icon.



**Figure 4-2. Hyd Return Filter icon - indicates clogged hydraulic filters**

### Accessing and Resetting Controller Service Intervals

After changing the oil, air filter, engine fuel filter, or hydraulic oil filters; the appropriate interval **MUST BE RESET ON THE CONTROLLER** in order to continue providing accurate data.

#### Engine Oil, Fuel Filter, and Air Filter

1. See [Figure 4-3](#). On the Service Alerts page, press the Diagnostics button (A),

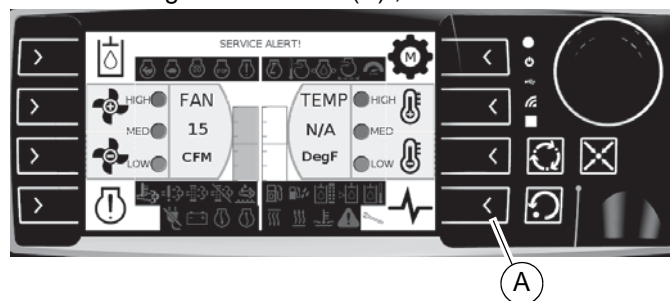

**Figure 4-3. Service Alerts Page**

2. See [Figure 4-4](#). The Engine Diagnostics page displays. Press the indicated button (A)

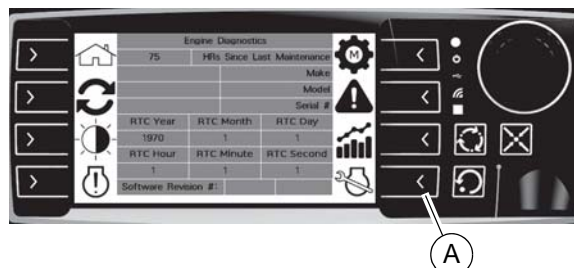

**Figure 4-4. Engine Diagnostics Page**

See **Figure 4-5**. The Service Hours Engine page displays.

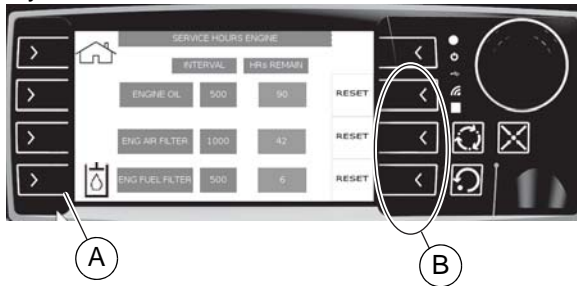

**Figure 4-5. Service Hours Engine Page**

3. On this page, you can:

- View service intervals.
- View hours remaining until next scheduled service.
- Press a RESET button to reset the corresponding HRs REMAIN (B).
- Access the hydraulic oil service interval (A).

### Hydraulic Oil

1. See **Figure 4-5**. On the Service Hours Engine page, press the indicated icon (A).

See **Figure 4-6**. The Service Hours Hydraulics page displays.

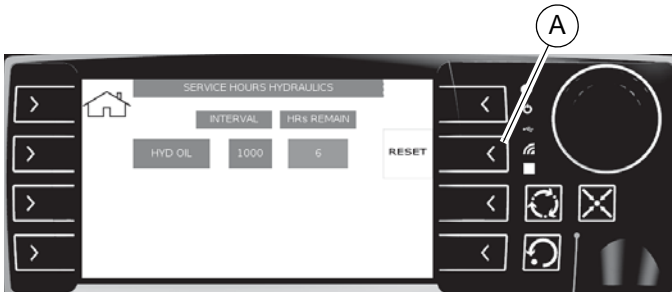

**Figure 4-6. Service Hours Hydraulics Page**

Here, you can:

- View service intervals.
- View hours remaining until next scheduled service.
- Press the RESET button to reset the HRs REMAIN for hydraulic oil (A).

## Other Maintenance Checks

The following inspections should be performed by an authorized service technician, or a properly trained authorized operator. These maintenance items require a high level of experience and skill to evaluate and correct.

- Inspect engine accessory drive belts
- Inspect hoses and connections
- Inspect fuel supply system
- Inspect exhaust system
- Inspect exhaust pipe sleeve



# Section 5: Troubleshooting

## General Troubleshooting Guide

Problem	Possible Cause	Solution
Engine cranks but does not start	No fuel	Verify there is no fuel leakage and replenish.
	Low oil level	Replenish oil to full.
	Emergency shutdown switch is ON	Turn emergency shutdown switch OFF.
	Air in fuel system	Purge air.
	Clogged fuel filter	Remove water and change element.
	Fuel is frozen	Warm fuel pipes with hot water or wait until ambient temperature rises.
	Injection pump failure	Contact an IASD.
	Electromagnetic type fuel pump failure	
	Engine control system failure	
	Restricted air flow	Check/replace air filter.
	LCD panel shows engine failure	Contact an IASD.
	Clogged strainer	
Pre-heating device failure		
Engine does not crank	Discharged battery	Replace battery.
	Battery terminal is disconnected, loose, or corroded	Replace corroded part and tighten securely.
	Starter ground terminal is disconnected, loose, or corroded	
	High engine oil viscosity	Change with oil of correct viscosity.
	Starter or electrical system failure	Contact an IASD.

Problem	Possible Cause	Solution
Engine starts but stops shortly thereafter	Low idle	Adjust by idling control equipment on the machine. If adjustment is not possible, contact ISUZU dealer.
	Clogged fuel filter	Remove water and change element.
	Clogged pre-fuel filter	Clean or change element.
	Clogged air cleaner	
	Engine control system failure	Contact an IASD.
	Injection pump failure	
	Clogged strainer	
	Electromagnetic type fuel pump failure	
Engine running is unstable	Fuel system failure	Purge air or remove water.
	Water or air is in fuel system	
	Engine control system failure	Contact an IASD.
Exhaust smoke is white	Insufficient warm-up time	Conduct warm-up operation.
	Excessive engine oil	Correct oil level.
	Engine control system failure	Contact an IASD.
	Injection pump failure	
	Fuel system failure	
Exhaust smoke is black	Excessive speed	Verify engine RPM. Check AVR adjustment.
	Injection pump failure	Contact an IASD.
	Clogged air cleaner	Clean or change element.
	Clogged intercooler	Contact an IASD.
	Fuel system failure	
	Clogged exhaust system	
Engine overheats	No coolant	Add coolant.
	Front of radiator is clogged with dust	Clean with soft brush.
	Sub tank cap is not tightened	Tighten or replace sub tank cap.
	Coolant is fouled	Clean inside of radiator and change coolant.
	Oil in coolant	Contact an IASD.
	Thermostat failure	Change thermostat.
Oil pressure does not rise	Incorrect engine oil viscosity	Change with oil of correct viscosity.
	Insufficient engine oil level	Replenish.
	Engine failure	Contact an IASD.
	Meter, lamp, or switch failure	

Problem	Possible Cause	Solution
Engine has no power	Clogged air cleaner	Clean element.
	Clogged pre-fuel filter	
	Clogged fuel filter	Remove water and change element.
	Clogged strainer	Contact an IASD.
	Engine control system failure	
	Engine failure	
	Clogged exhaust system	
	Fuel system failure	
	Incorrect fuel type	
	Electromagnetic type fuel pump failure	
Overheat/shutdown condition	Access doors are open	Close all access doors.
	Air outlets are not open	Open the air outlets and verify there are no obstructions or sharp bends in the ducting.
	Front radiator or rear oil cooler are full of debris	Clean the machine.
	Engine rpm is set too high based on ambient temperature	Lower the engine rpm.
	Faulty temperature sensor	Check air outlet sensor operation.
	Blower fan not operating correctly	Remove ducting; check blower fan operation.
No/low heat condition	Incorrect heater setting (target temperature too low)	Adjust heater output.
	Access doors are open	Close all access doors.
	Low HTF/hydraulic oil level	<ul style="list-style-type: none"> <li>• Check level on tank sight glass, adjust as needed.</li> <li>• Inspect HTF hoses for leaks or loose fittings.</li> <li>• Check fluid for foaming.</li> </ul>
	HTF/hydraulic oil filters clogged	Check restriction gauges/replace HTF filters.
	Ducting too long for ambient conditions	Move unit closer to heat recipient if possible.
	HTF pump drive sheared	Contact an IASD.

**IMPORTANT NOTE: See the OEM engine manual for related troubleshooting.**

## Controller Warnings and Faults



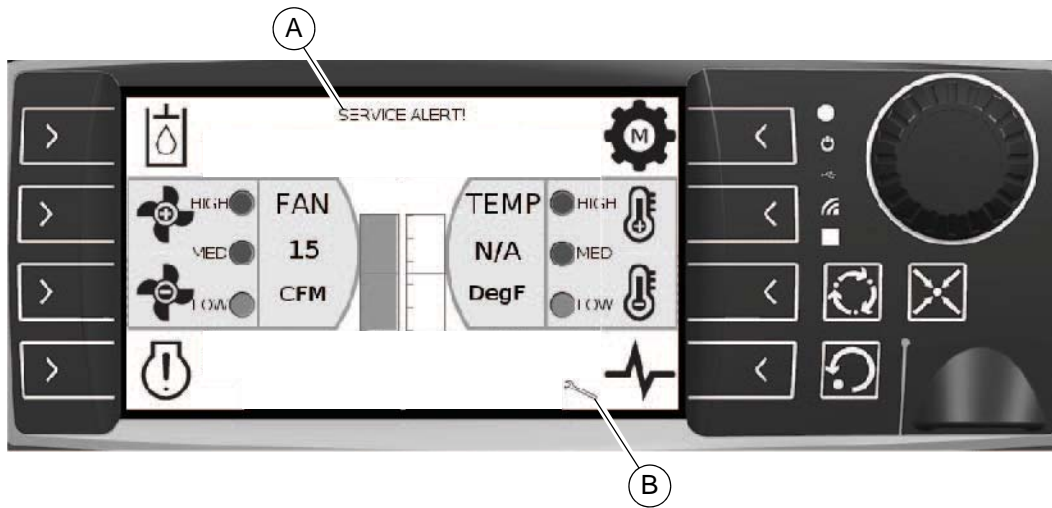







See **Figure 5-1** The controller indicates warnings and faults by displaying messages in the message bar (A) and/or by displaying an icon (B, for example).



**Figure 5-1.**

**NOTE:** For more information on warnings and faults, contact Generac Mobile Technical Service at 1-800-926-9786.

Icon	Icon ID	State	Indicated Condition
	Engine Stop/Shutdown	Steady ON	Indicates engine shutdown required for severe system faults/events.
	Engine Warning	Steady ON or Slow flash or Fast flash	Used to indicate engine and emissions system diagnostics.
	High Exhaust Temperature (HEST)	Steady ON	Engine is NOT at idle and the engine ECU is requesting high idle (typically, 1,200 rpm) Control system has granted permission for high idle state Typical when DPF is above 80% soot load
	DEF Fluid Level	Steady ON (amber)	DEF fluid level is 20%
		Slow flash (red)	DEF fluid level is 16% or below
	Engine Emissions Malfunction	Steady ON or Slow flash or Fast flash	Indicates failure of a critical emissions component. Engine derate: <ul style="list-style-type: none"> <li>• Steady ON: 0%</li> <li>• Slow flash: 50%</li> <li>• Fast flash: 100%</li> </ul>
	Regen Inhibit	Steady ON(amber)	Control system not allowing high idle that engine has requested
	Engine Oil Pressure	Steady ON	Severity level 1—0% derated engine power
		Flashing	Severity level 3—100% derated engine power
	Engine Intake Temperature	Steady ON (amber)	Engine intake temperature is above 253 °F (123 °C) <b>IMPORTANT NOTE: Temperature above 253 °F (123 °C) begins to deteriorate engine!</b>
	Hydraulic Oil Level Low	Fast flash (red)	Low hydraulic oil level

	Hydraulic Oil Temperature	Steady ON (amber)	Tank >160 °F (71 °C) or oil stream >200 °F (93 °C)
		Steady ON (red)	Tank >170 °F (77 °C) or oil stream >210 °F (99 °C)
		Steady ON	High-temperature cut-out switch open
	Hydraulic Return Filter		Filter condition
	Engine Overspeed	Steady ON	Engine rpm exceeds set parameter in EPEC ECU for overspeed, or the engine ECU transmits the overspeed indication Remains ON until engine cycles through a stopped state Setpoint: 2,600 rpm
	Low Diesel Fuel	Steady ON (amber)	Fuel level is 20%
		Slow flash (red)	Fuel level is 16%
		Fast flash (red)	Fuel level is 12% or below
	Control System Fault	Steady ON	Any control system fault
	Delayed Engine Shutdown	Steady ON	DPF outlet temperature is above a set temperature threshold
		Steady ON (amber) and Steady ON—Engine Cooling lamp	Engine is cooling
	Battery Charge	Steady ON	Battery voltage is below 25 V with engine in RUN
	Engine Coolant Temperature	Steady ON (amber)	Coolant level is above 228 °F (109 °C)
	Water In Fuel	Steady ON	Water detected in fuel
	Service Due	Steady ON	Service is due for one or more of: <ul style="list-style-type: none"> <li>• Engine oil</li> <li>• Air filter</li> <li>• Engine fuel filter</li> <li>• Hydraulic oil filters</li> </ul> See <a href="#">Draining Fluids—Union Fluid Drain</a> .

**This page intentionally left blank.**

# Section 6: Wiring Diagrams

## Main Control System

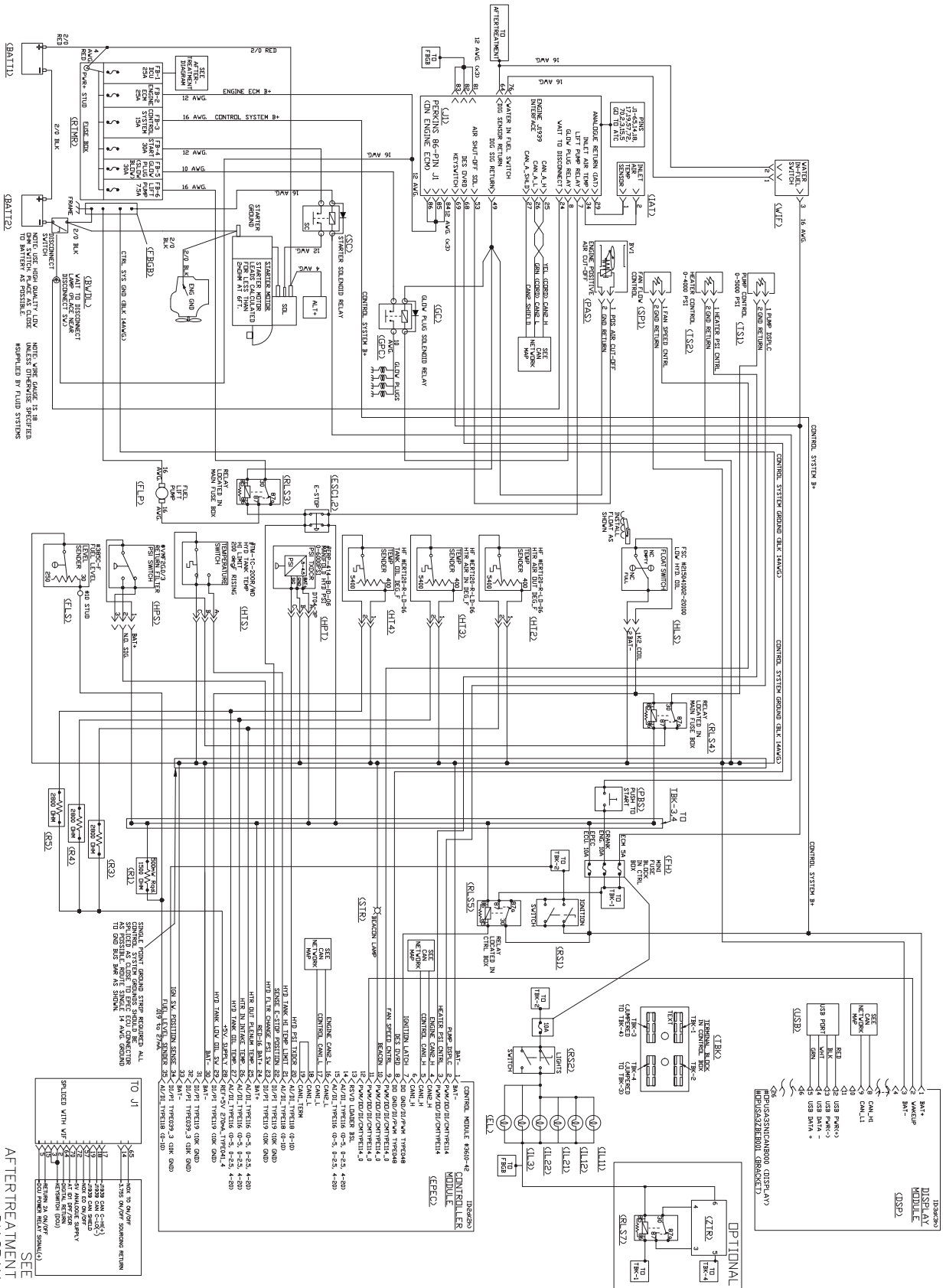

# Perkins Engine Aftertreatment

## GROUP G

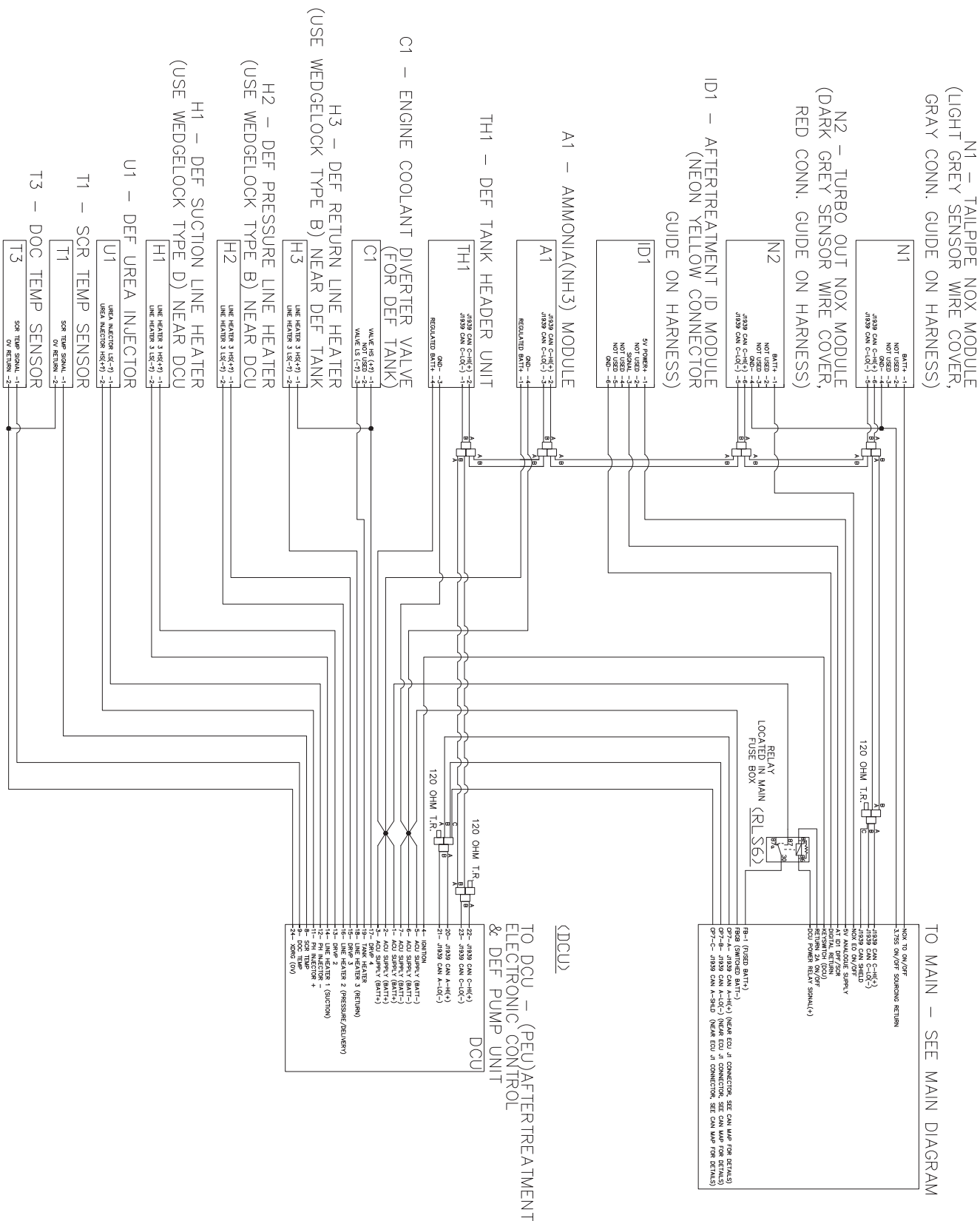



# J1939 CAN Bus Network

## GROUP G

J1939 CANBUS NETWORK DIAGRAM

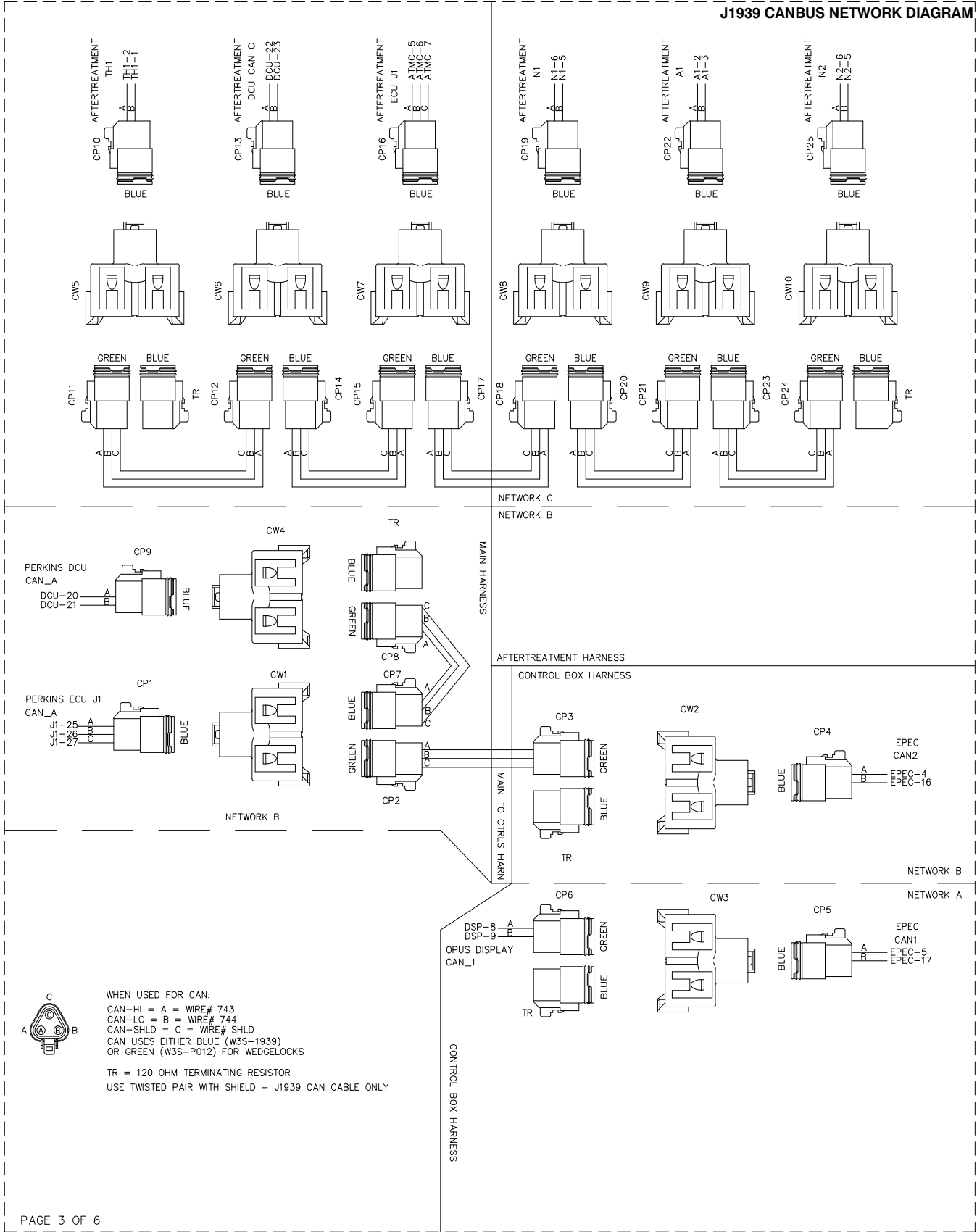

# Trailer Harness—Electric Brakes

## GROUP G

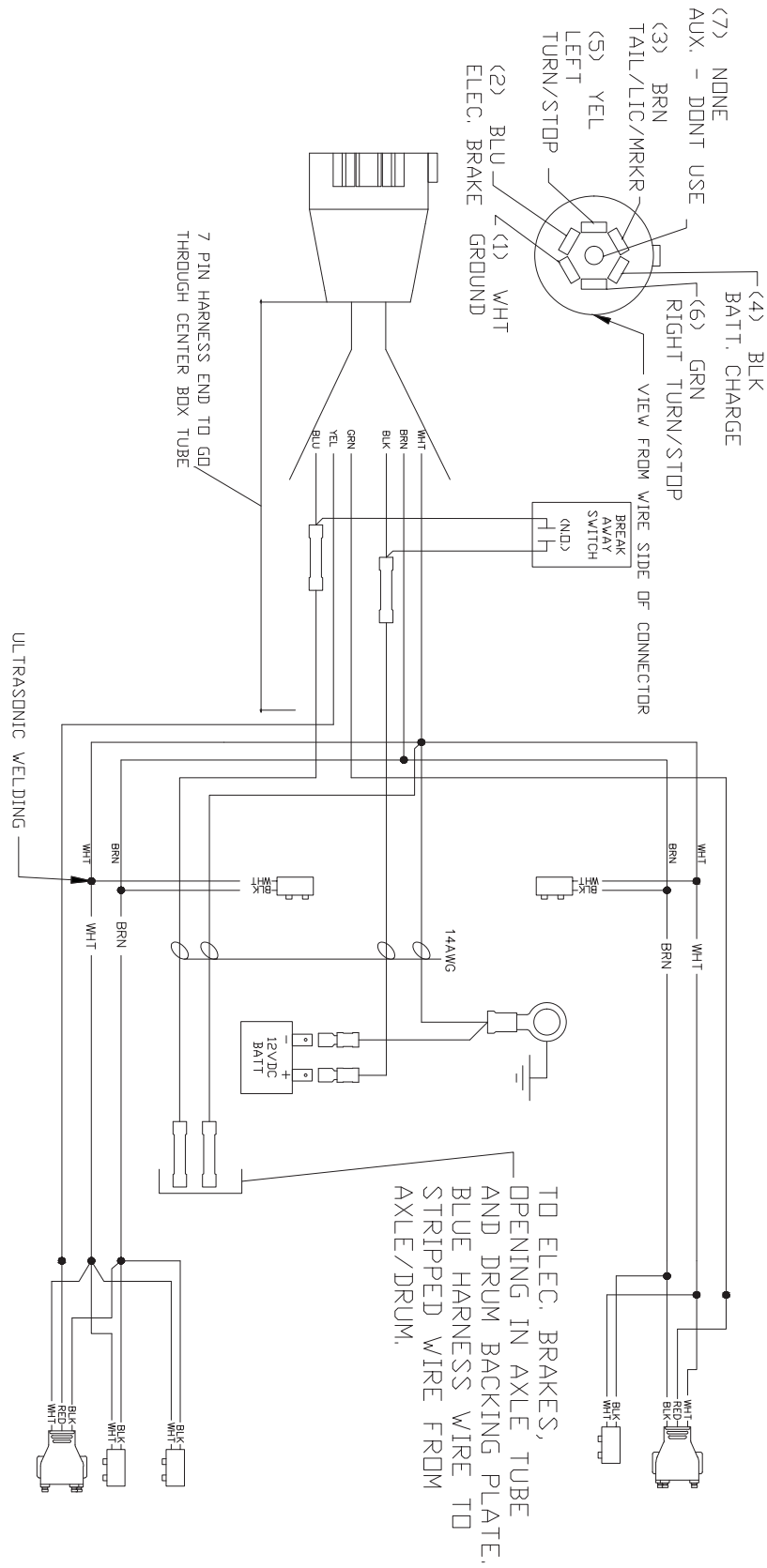

# Trailer Harness—Lights Only or With Surge Brakes

## GROUP G

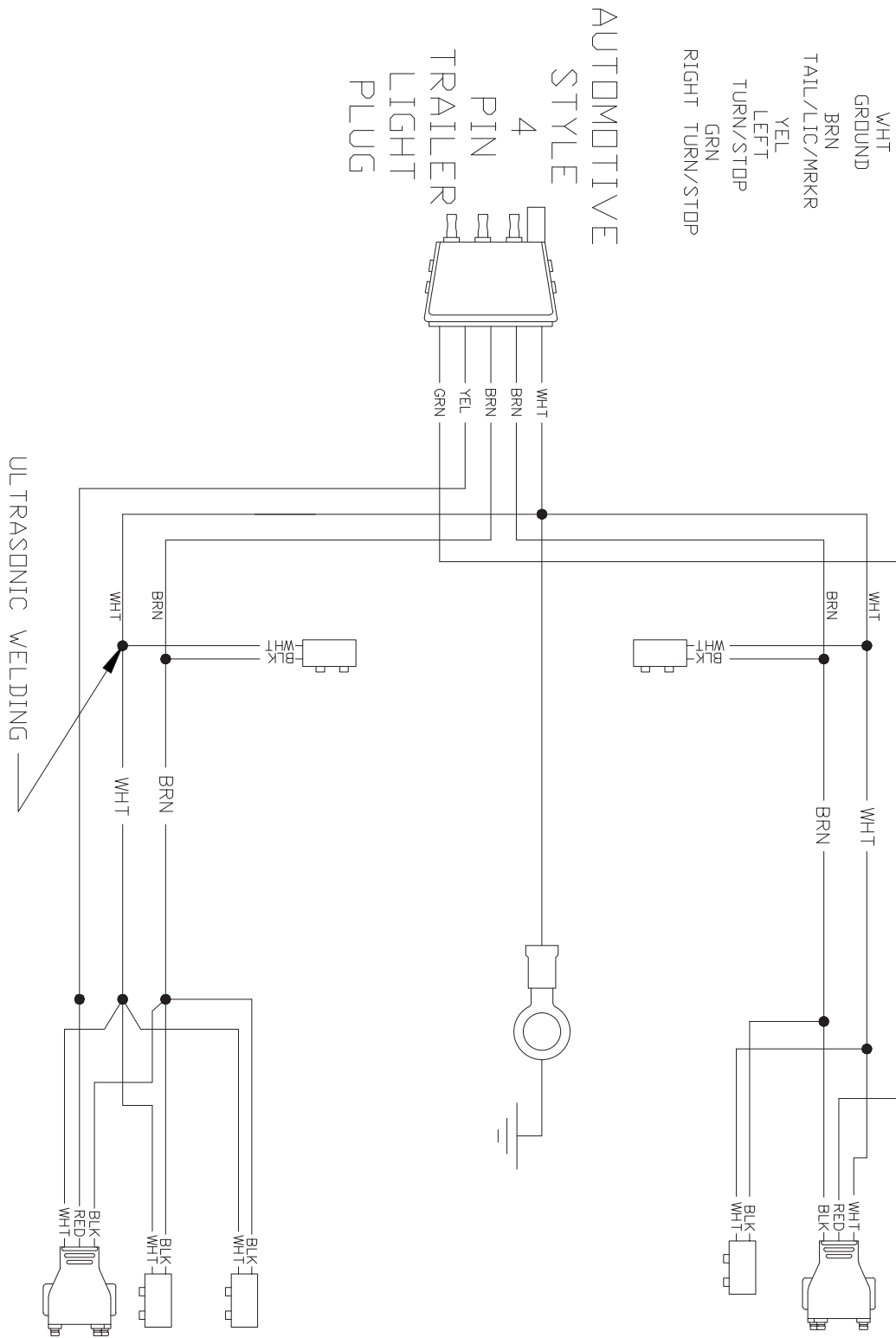

PAGE LEFT BLANK  
INTENTIONALLY



**This page intentionally left blank.**



Part No. A00004483332 Rev A 10/23/2019

©2018 Generac Mobile Products, LLC

All rights reserved.

Specifications are subject to change without notice.

No reproduction allowed in any form without prior written consent from Generac Mobile Products, LLC.

**GENERAC** | **MOBILE**

Generac Mobile Products, LLC  
215 Power Drive, Berlin, WI 54923

[GeneracMobileProducts.com](http://GeneracMobileProducts.com) | 800-926-9768 | 920-361-4442