

PLT240

LED Light Tower Parts Manual

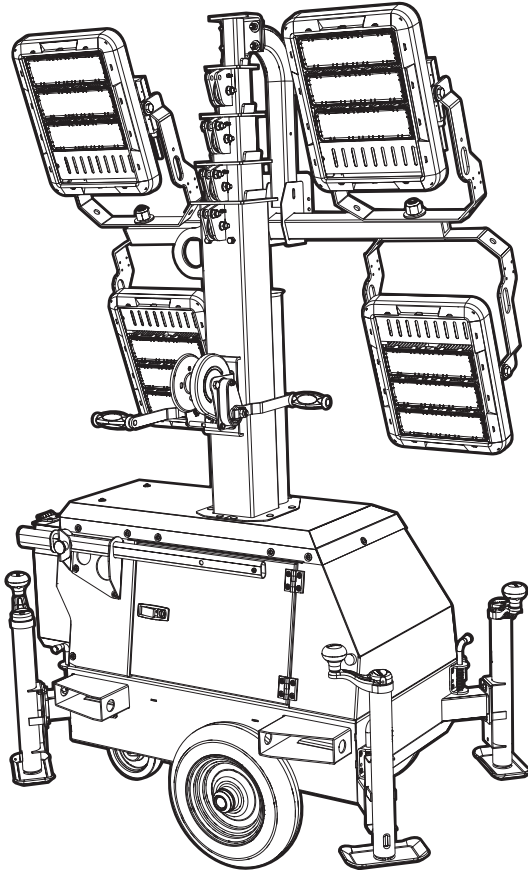

02644

MODEL NUMBER: _____

SERIAL NUMBER: _____

DATE PURCHASED: _____

SAVE THIS MANUAL FOR FUTURE REFERENCE

 **WARNING**

CANCER AND REPRODUCTIVE HARM

www.P65Warnings.ca.gov

(000393a)

Introduction

This parts manual was prepared based on the information available at the time of publication and is subject to change without notice. Generac Mobile Products reserves the right to change parts at any time. To check whether a revised parts manual is available, contact Generac Mobile Products.

DO NOT MODIFY or use this equipment for any application other than which it was designed for. To keep your equipment fully operational, it is suggested you maintain a stock of commonly used maintenance or service parts. A recommended spare parts list can be found in the back of this manual. To order service parts, please go to www.generacmobileproducts.com or call Generac Mobile Products.



WARNING

Consult Manual. Read and understand manual completely before using product. Failure to completely understand manual and product could result in death or serious injury. (000100a)

WARNING

Environmental Hazard. Always recycle batteries at an official recycling center in accordance with all local laws and regulations. Failure to do so could result in environmental damage, death or serious injury. (000228)

GENERAC MOBILE PRODUCTS LLC

215 Power Drive • Berlin, WI 54923 U.S.A.

Phone: 920-361-4442

FAX: 920-361-4416

Toll Free: 1-800-926-9768

www.generacmobileproducts.com

For technical or parts QUESTIONS, contact Generac Mobile Products Technical Service at 1-800-926-9768.

Engine Make: _____

Engine Serial Number: _____

Engine Model Number: _____

This Page Intentionally Left Blank

Table of Contents

Introduction	iii
Parts Manual Instructions	1
Unit Decals - Left Side	2
Unit Decals - Right Side	4
Lights, Doors and Control Box to Unit	6
Enclosure Assembly	8
Light Mast Assembly	10
Light Assembly	12
Mast Junction Box Assembly	14
Mast Assembly	16
Mast Base Assembly	18
Control Panel Cover	20
Control Panel Assembly (1 of 3).....	22
Control Panel Assembly (2 of 3).....	24
Control Panel Assembly (3 of 3).....	26
Trailer Assembly	28
Recommended Spare Parts	30

This Page Intentionally Left Blank

Parts Manual Instructions

Product illustrations are only representations. Products supplied may vary from the illustrations in this parts manual. Parts not shown in the illustration are indicated by a double dash (--) in the item column.

Please be prepared to provide the following information when ordering replacement parts: model number, serial number (on unit serial tag), part number, purchase order number (if applicable), shipping address, shipping method.

Refer to the illustration below to locate the unit ID tag on the unit. Important information, such as the unit serial number, model number, and tire loading information are found on these tags. Record the information from these tags so it is available if the tags are lost or damaged. When ordering parts or requesting assistance, you may be asked to provide this information.

Manufactured by Generac Mobile Products, LLC.
 (920) 361-4442 (800) 926-9768

Country of Origin	Model	Serial Number
Manufacturing Code	Weight (lbs/kg)	RPM/Frequency

1 ph. 1.0PF	3 ph. .8PF	3 ph. 1.0PF	Rating	Ins. Class
KW				
KVA				Production Date
V				
A				

SUITABLE FOR WET LOCATIONS

 FOR ELECTRICAL EQUIPMENT ONLY. FODR MATERIAL. ELECTROSTATIC DISCHARGE. 225649
 Form SF0226

*Located on mast
 inside enclosure*

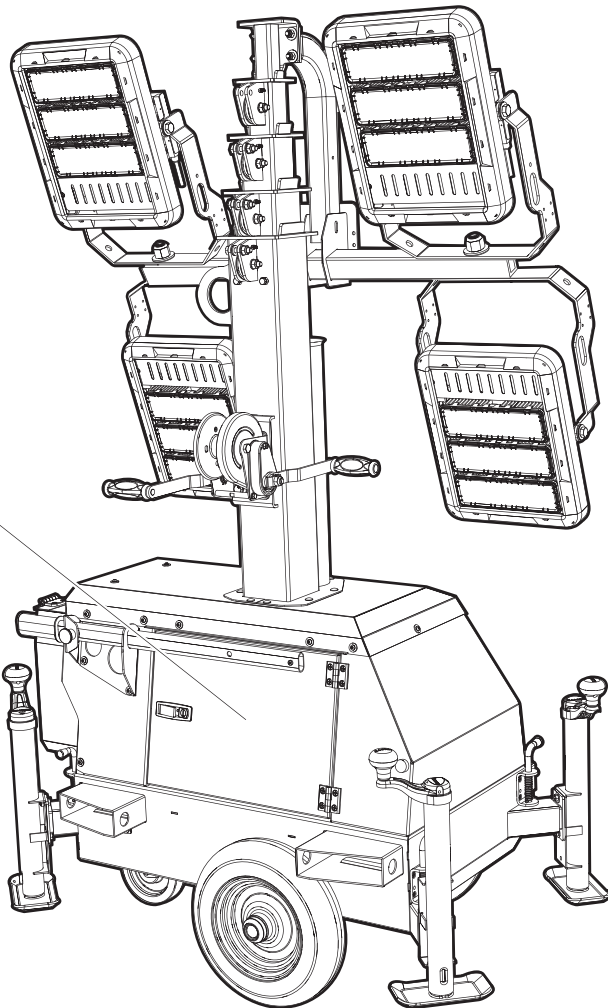

02645

UNIT DECALS - LEFT SIDE

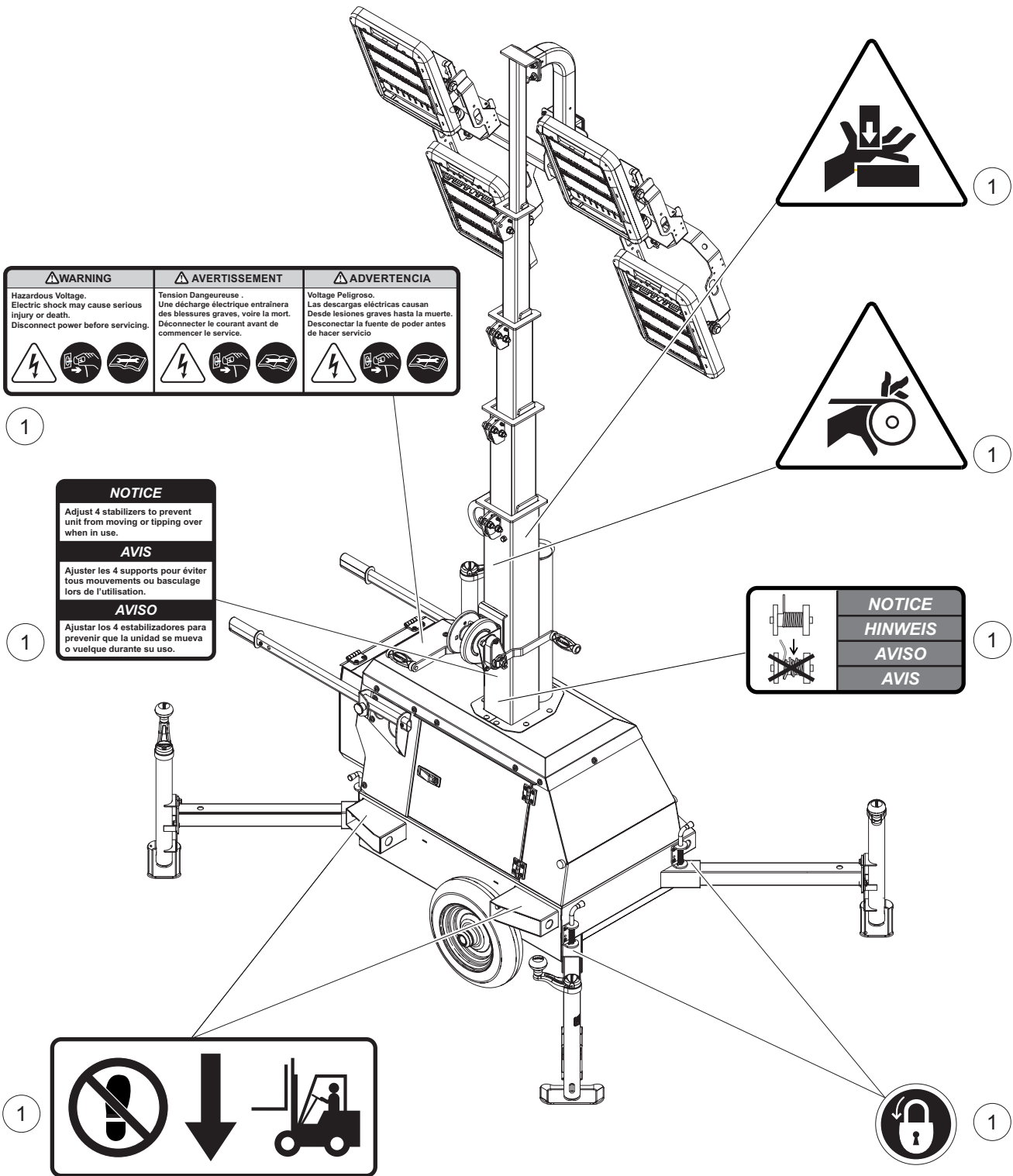

02646

UNIT DECALS - LEFT SIDE

Item	Part No.	Qty	Description	Notes
1	54939	1	Decals, safety, Rev A	

UNIT DECALS - RIGHT SIDE

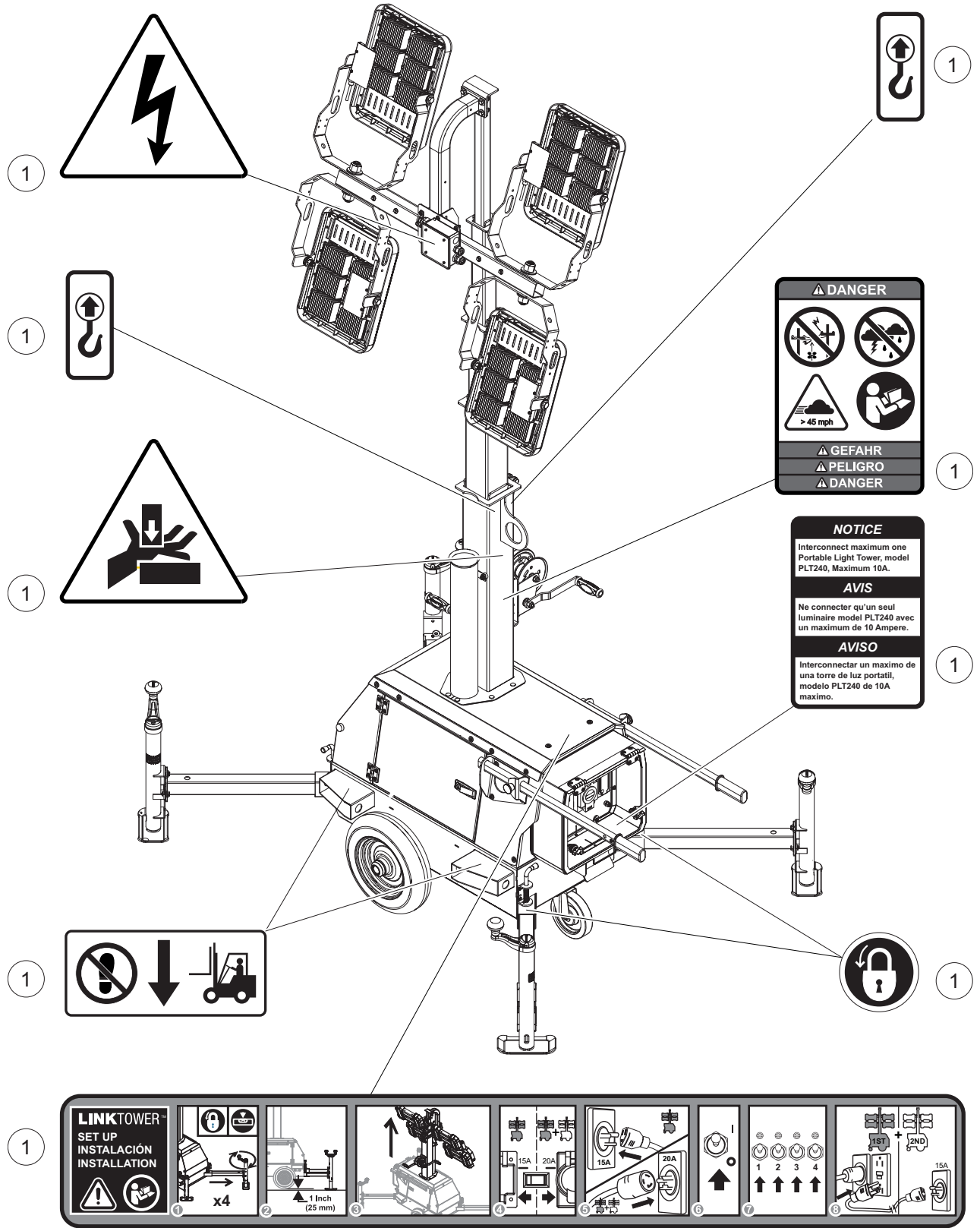

02647

UNIT DECALS - RIGHT SIDE

Item	Part No.	Qty	Description	Notes
1	54939	1	Decals, safety, Rev A	

LIGHTS, DOORS AND CONTROL BOX TO UNIT

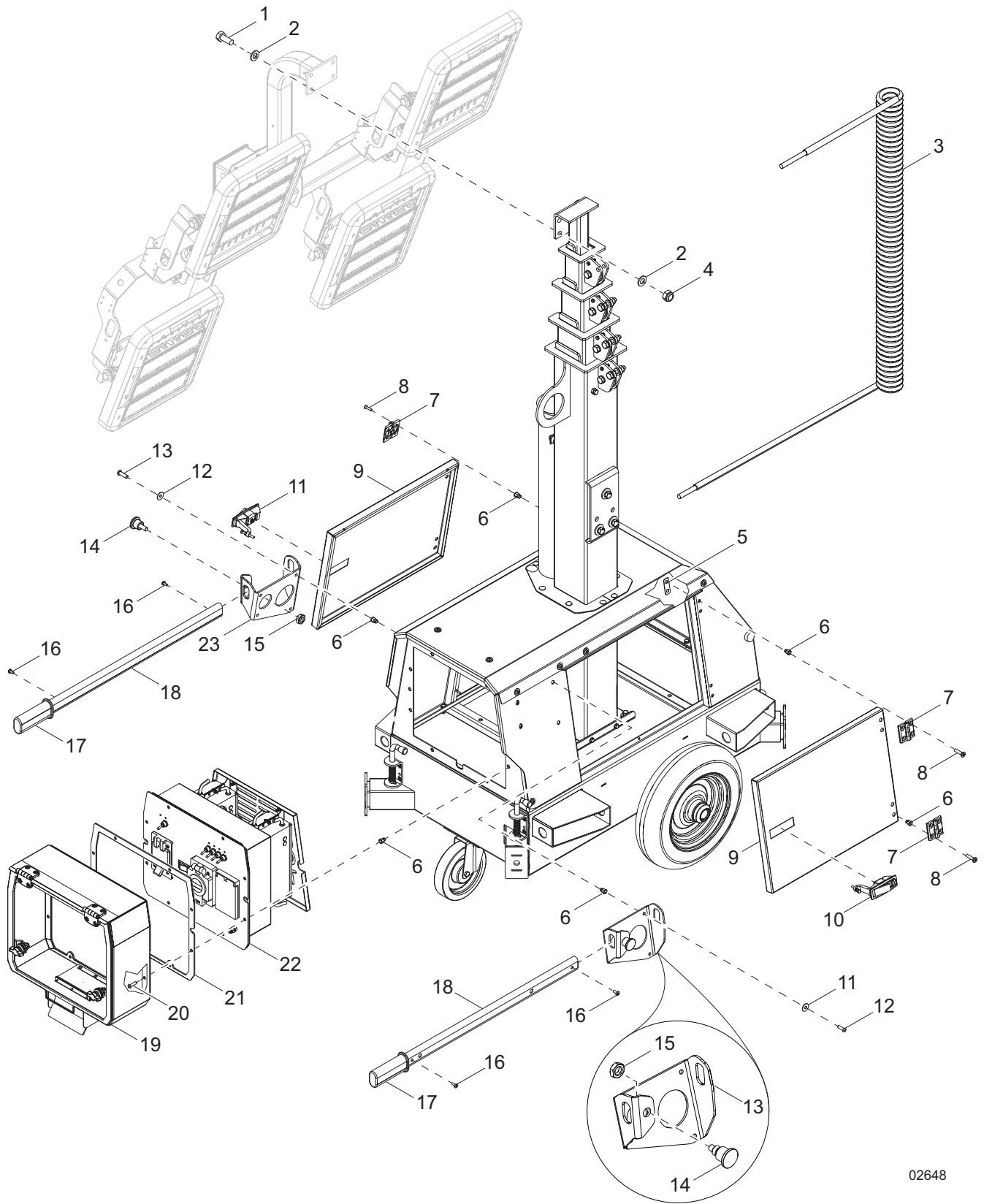

02648

LIGHTS, DOORS AND CONTROL BOX TO UNIT

Item	Part No.	Qty	Description	Notes
1	60352	4	Screw, .375-16 x 1.25 standard hex, G5	
2	60386	8	Washer, .375 .993/.064	
3	10000026846	1	Cord, coil #14/9 53 in - tail	
4	60358	4	Nut, .375-16 nylock - G5	
5	55089	4	Bracket, hinge mount	
6	69991	34	Insert, M6-1.00 hex .50-3.00mm grip	
7	56538	4	Hinge	
8	69979	16	Screw, M6-1.10 x 20 Phillips flat - SS	
9	56549	2	Panel, enclosure door	
10	56539	2	Handle, door - locking	
11	69975	8	Washer, M6 flat	
12	69978	8	Screw, M6-1.00 x 20 button hex	
13	56540	1	Bracket, handle mount - right	
14	56544	2	Plunger, pin 10MM	
15	69990	2	Nut, M16-1.5 jam, G4	
16	69976	4	Screw, M5-.800 x 12 pan Phillips	
17	56543	2	Grip, handle 30MM	
18	56542	2	Handle, grip 30MM x 740MM	
19	76941	1	Assembly, control panel cover	page 20
20	69984	10	Screw, M6-1.00 x 30 button hex	
21	76929	1	Gasket, control panel	
22	55090	1	Assembly, control box w/drivers	page 24
23	56541	1	Bracket, handle mount - left	

ENCLOSURE ASSEMBLY

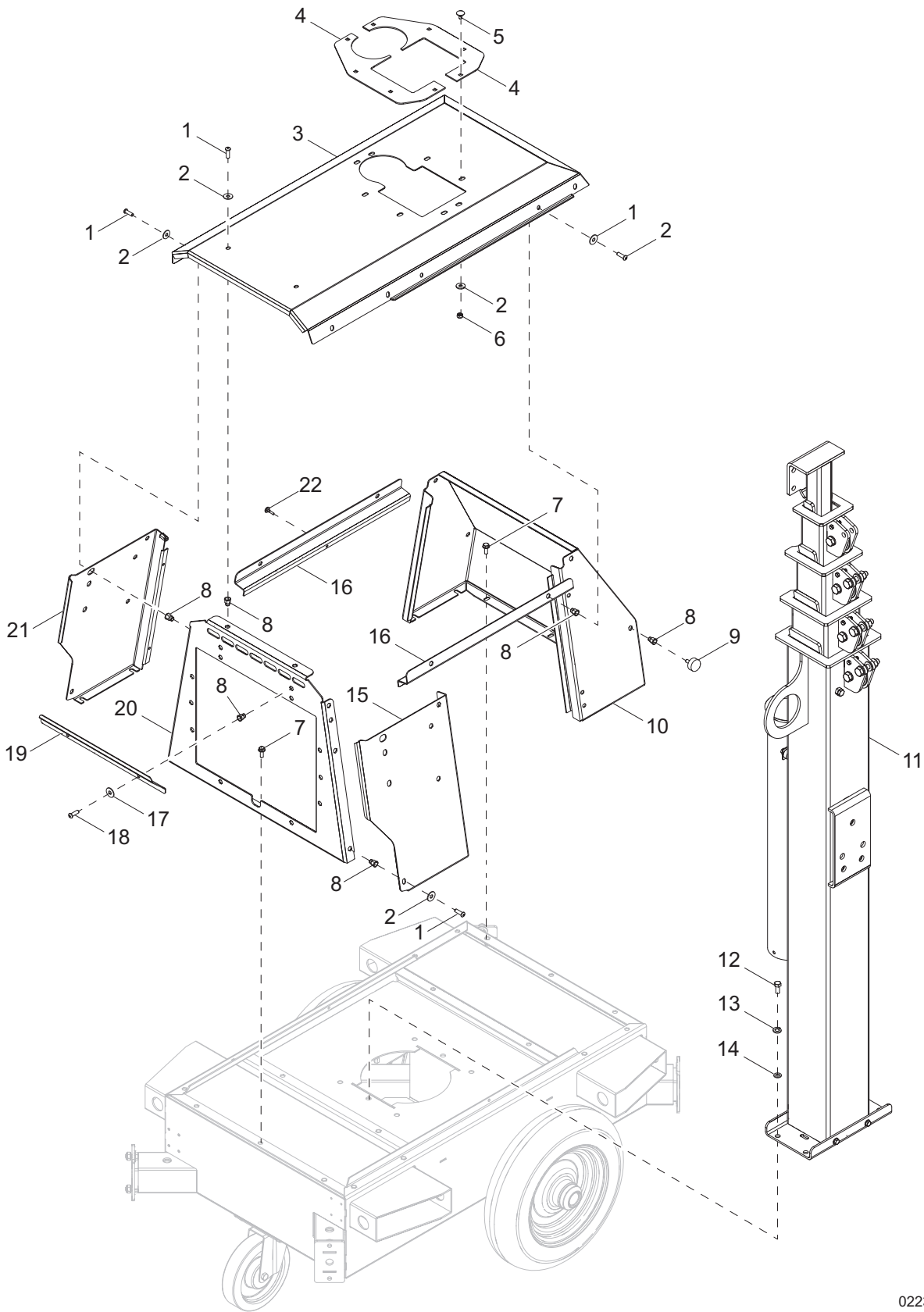

02233

ENCLOSURE ASSEMBLY

Item	Part No.	Qty	Description	Notes
1	69978	15	Screw, M6-1 x 20 button hex	
2	69975	15	Washer, flat M6	
3	56526	1	Panel, enclosure roof	
4	56535	2	Bracket, mast guide - right	
5	69980	8	Screw, M6-1.00 x 16 carriage, G4	
6	60047	8	Nut, M6 nylock, G8.8	
7	60087	14	Screw, M6-1.00 x 16 serrated flange, G8.8	
8	69991	27	Insert, M6-1.00 hex .50-3.00mm grip	
9	56537	2	Stopper, door - rubber	
10	56525	1	Panel, enclosure - back	
11	56552	1	Assembly, mast	
12	61082	4	Screw, M8-1.25 x 20 standard hex, G8.8	
13	60029	4	Washer, M8 split lock	
14	69981	4	Washer, M8 flat	
15	56524	1	Panel, enclosure - front right	
16	56527	2	Jamb, door - top	
17	69983	2	Washer, M6 flat	
18	69982	2	Screw, M6-1.0 x 16 button hex	
19	56522	1	Cover, enclosure - vent	
20	56521	1	Panel, enclosure - front	
21	56523	1	Panel, enclosure -front left	
22	56536	4	Stopper, door jamb - rubber	

LIGHT MAST ASSEMBLY

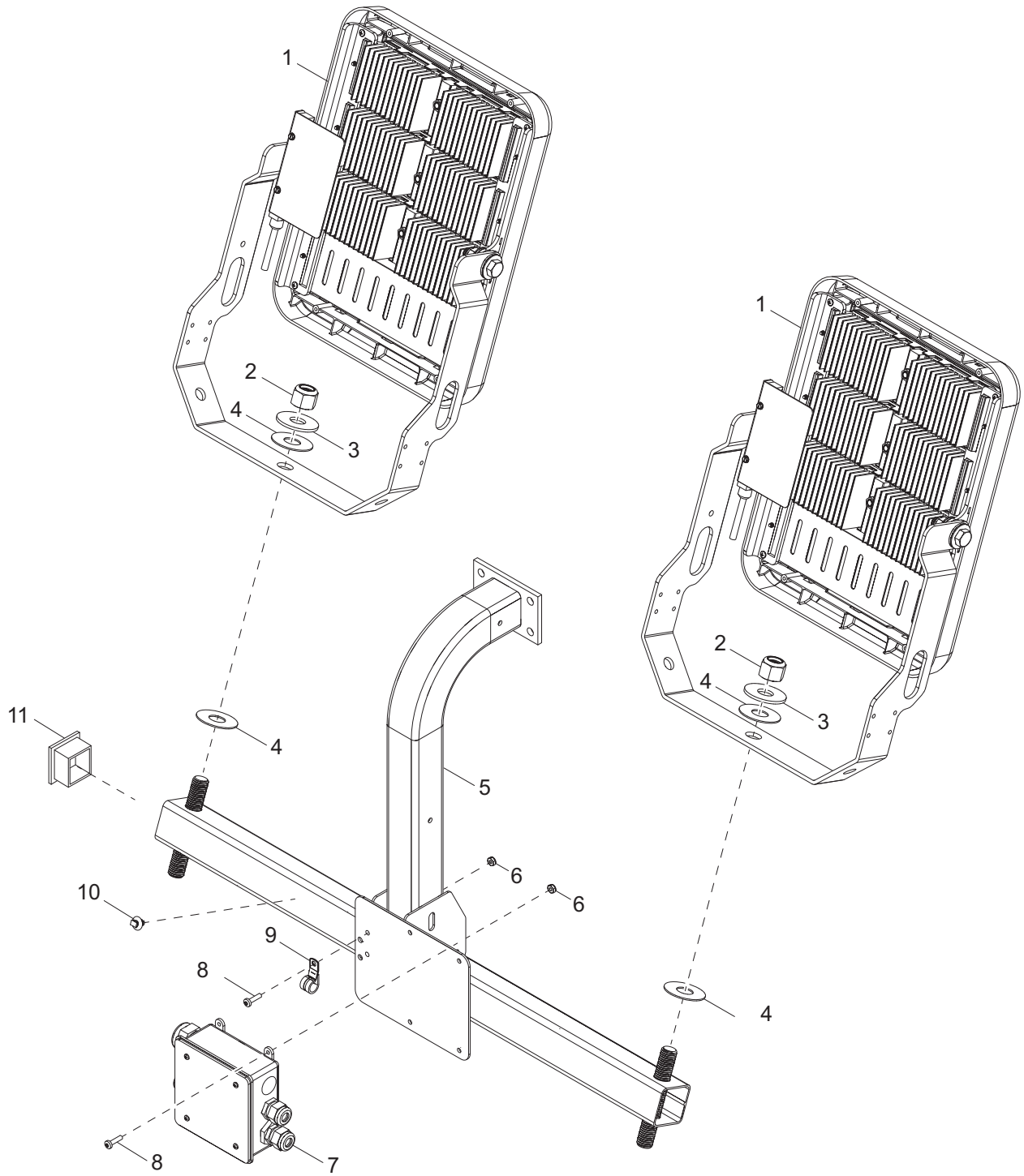

00000

LIGHT MAST ASSEMBLY

Item	Part No.	Qty	Description	Notes
1	10000032932	4	Assembly, LED light - 3 module, horizontal	
2	60584	4	Nut, .750-10 nylock	
3	60247	4	Washer, .750 flat 2.020/.130	
4	63357	8	Washer, .750 flat 2.0/.062 - plastic	
5	43201B	1	Weldment, mast, crossbar	
6	60061	5	Nut, 10-32 nylock	
7	72174SRV	1	Assembly, mast box - LED	
8	60062	5	Screw, 10-32 x .750 pan Phillips, G2	
9	16143	1	Clamp, tubing .500	
10	66685	6	Mount, cable tie	
11	10000023259	2	Plug, 2.0 square x .125 wall tube, plastic	

LIGHT ASSEMBLY

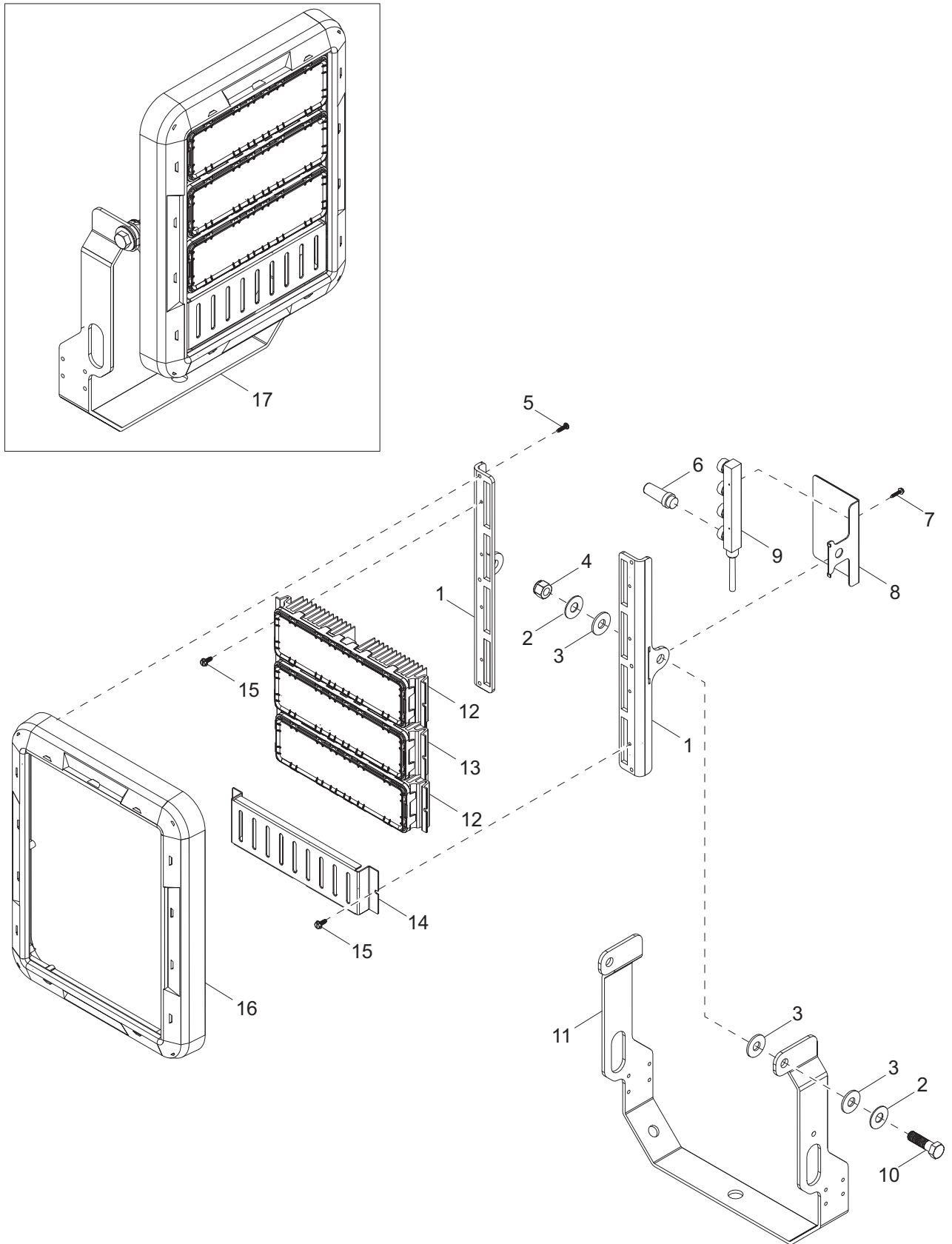

02650

LIGHT ASSEMBLY

Item	Part No.	Qty	Description	Notes
1	10000019192	2	Support, frame 4 LED module	
2	60700	4	Washer, .500 flat 1.25/.060 - SS	
3	72134	6	Washer, .500 nylon 1.25/.100	
4	62221	2	Nut, .500-13 nylock, G5	
5	10000019163	6	Screw, 8-16 x .625 PLST pan Phillips	
6	10000032905	1	Plug, ZJ seal connector block - LED	
7	73219	2	Screw, 6-20 x .750 sheet metal - SS	
8	10000019164	1	Bracket, connector block	
9	72120	1	Connector block, 4 module	
10	60830	2	Screw, .500-13 x 1.75 hex - SS	
11	10000023721	1	Trunnion, LED module - horizontal	
12	10000019170	2	Module, 60° 28 LED 24-27VDC - 60W	
13	10000019160	1	Module, 40° 28 LED 24-27VDC - 60W	
14	10000032906	1	Bracket, module blank	
15	10000019182	8	Screw, 10-24 x .500 hex - flanged	
16	10000019135	1	End cap, LED module - horizontal	
17	10000032932	1	Assembly, LED 3 module w/ blank	Items 1-16

MAST JUNCTION BOX ASSEMBLY

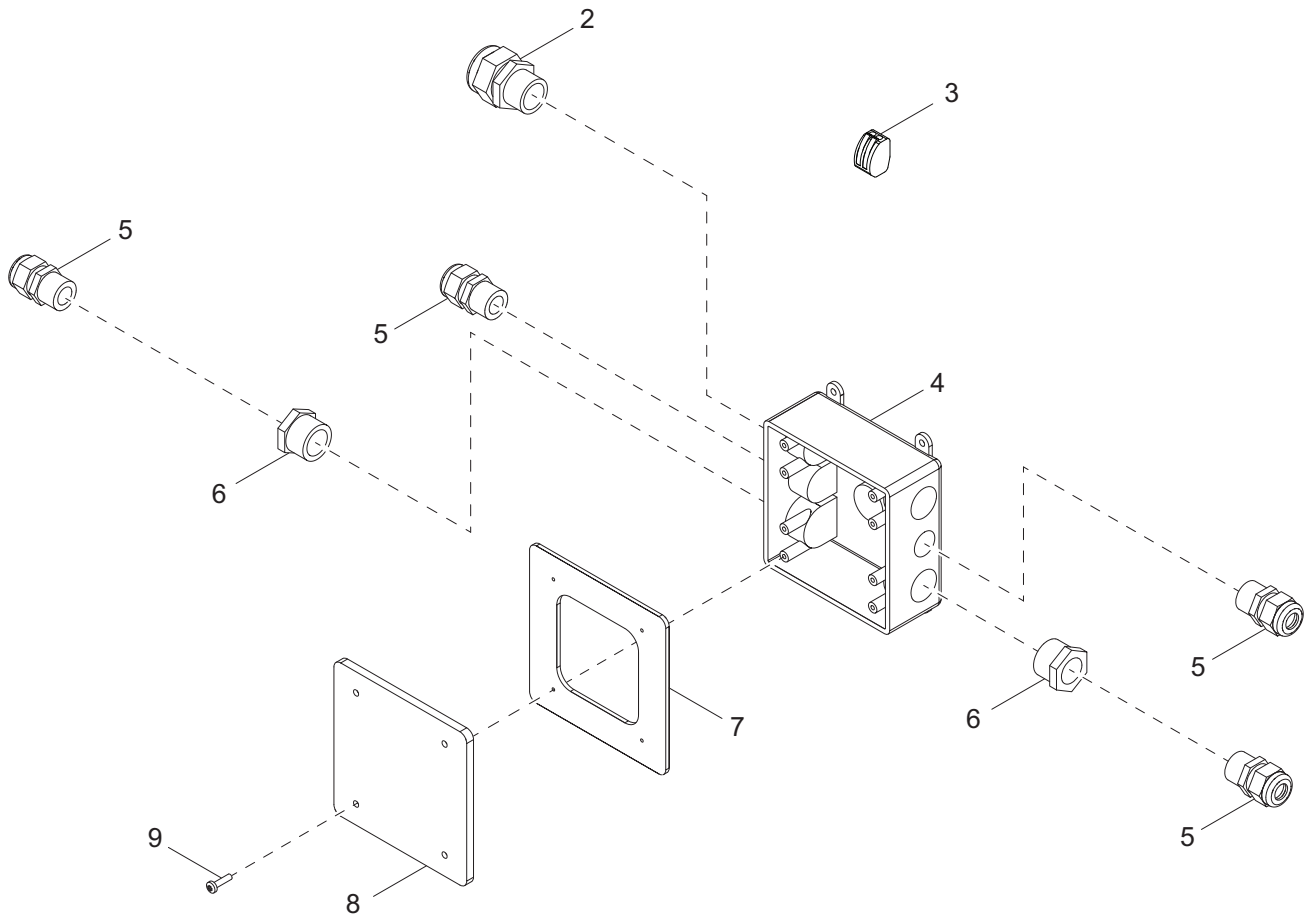
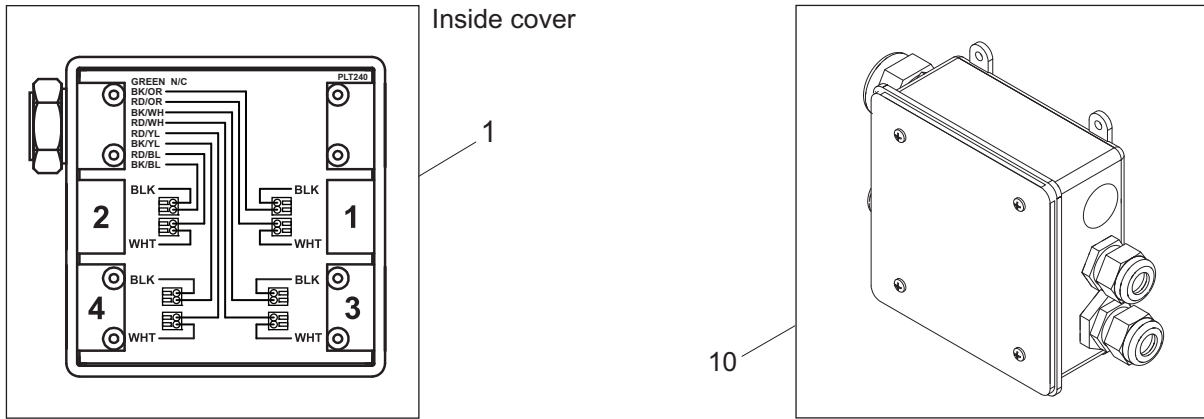

02651

MAST JUNCTION BOX ASSEMBLY

Item	Part No.	Qty	Description	Notes
1	73123	1	Decal, mast junction box	
2	14656	1	Strain relief, .750NPT water tight	
3	66100	8	Connector, 2 position	
4	12094	1	Box, junction	
5	15864	4	Strain relief, .500NPT water tight	
6	60755	2	Fitting, straight .750MNPT x .500FNPT, nylon	
7	13749SRV	1	Gasket, junction box - HFI 281000	
8	12109	1	Cover, box, 2-gang plastic	
9	60424	4	Screw, 6-32 x .750 pan Phillips, G2	
10	72174	1	Assembly, junction box	

MAST ASSEMBLY

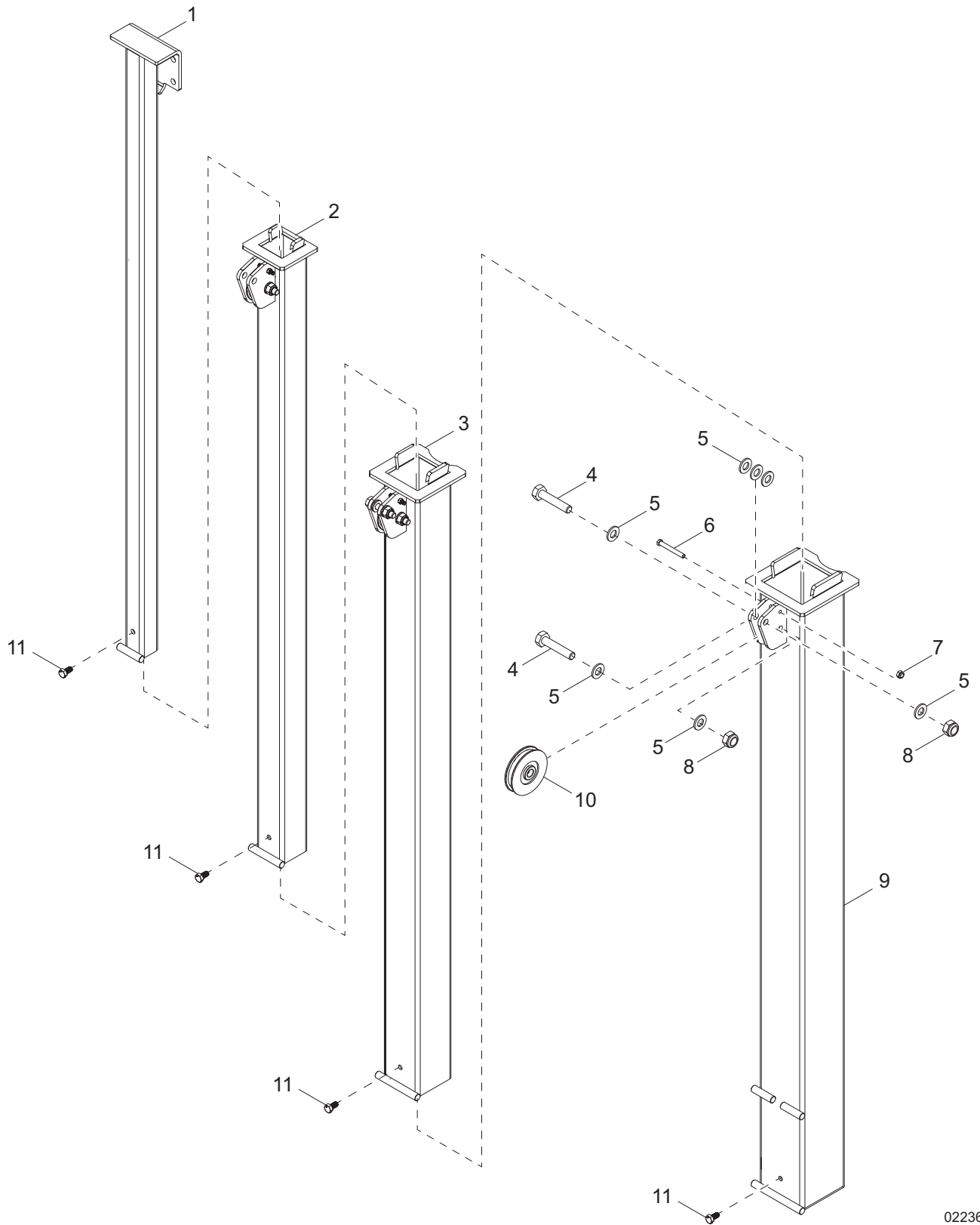

02236

MAST ASSEMBLY

Item	Part No.	Qty	Description	Notes
1	56532	1	Weldment, mast 40MM	
2	56531	1	Weldment, mast 60MM	
3	56530	1	Weldment, mast 80MM	
4	69970	5	Screw, M10-1.50 x 55 standard hex, G8.8	
5	69971	16	Washer, M10 flat	
6	69969	3	Screw, M5-.80 x 40 standard hex, G8.8	
7	60038	3	Nut, M5-.80 nylock, G6	
8	60097	5	Nut, M10-1.50 nylock, G8.8	
9	56529	1	Weldment, mast 100MM	
10	56534	3	Pulley, 62mm x 10.5mm	
11	60113	4	Screw, M8-1.125 x 16 standard hex, G8.8	
--	56545	1	Cable, .5 x 88.6 long	top cable
--	56546	1	Cable, .5 x 44.9 in. long	bottom cable
--	56547	2	Cable, .5 x 45.7 in. long	middle cable

MAST BASE ASSEMBLY

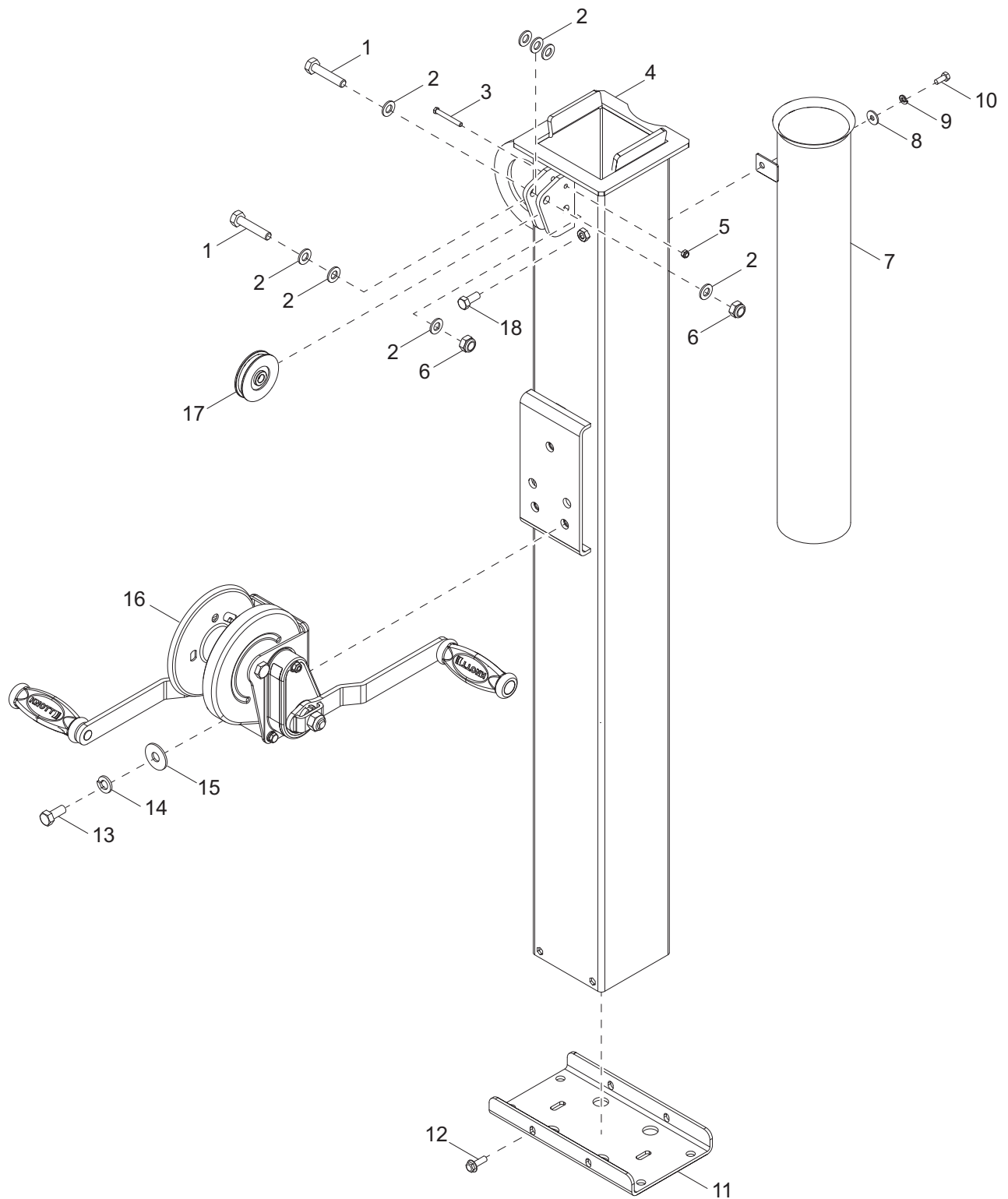

02237

MAST BASE ASSEMBLY

Item	Part No.	Qty	Description	Notes
1	69970	2	Screw, M10-1.50 x 55 standard hex, G8.8	
2	69971	7	Washer, M10 flat	
3	69969	1	Screw, M5-.80 x 40 standard hex, G8.8	
4	56528	1	Weldment, mast 120mm	
5	60038	1	Nut, M5-.80 nylock, G6	
6	60097	2	Nut, M10-1.50 nylock, G8.8	
7	56533	1	Tube guide, coil cord	
8	69975	1	Washer, M6 flat	
9	38522	1	Washer, M6 split lock	
10	69974	1	Screw, M6-1.0 x 12 standard hex, G8.8	
11	56520	1	Bracket, mast mount	
12	60087	4	Screw, M6-1.00 x 16 serrated flange hex, G8.8	
13	69972	3	Screw, M10-1.50 x 25 standard hex, G8.8	
14	60026	3	Washer, M10 split lock	
15	69973	3	Washer, M10 flat	
16	72127	1	Winch, manual 1500lb - dual handle	
17	56534	1	Pulley, 62mm x 10.5mm	
18	61082	2	Screw, M8-1.25 x 20 standard hex, G8.8	

CONTROL PANEL COVER

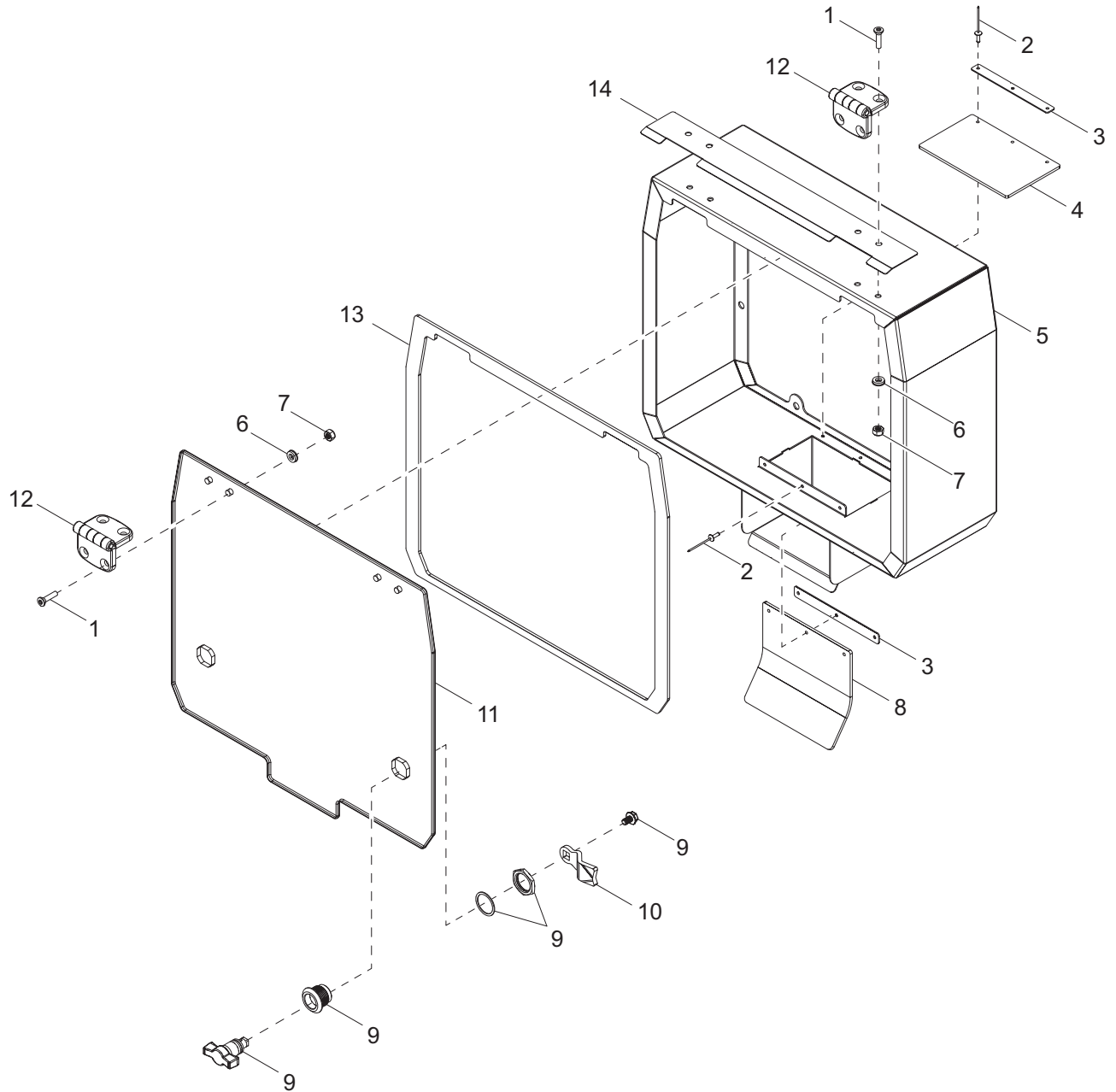

02238

CONTROL PANEL COVER

Item	Part No.	Qty	Description	Notes
1	69967	8	Screw, M6 x 1.00 - 20 flat Phillips - SS	
2	60267	6	Rivet, .125 dia x .191 to .270 grip	
3	76949B	2	Plate, backing	
4	10000007754	1	Flap, cover - rubber	
5	76940	1	Weldment, control panel cover	
6	69968	8	Washer, sealing .26 x .50 - SS/neoprene	
7	60047	8	Nut, M6-1.00 nylock, G8.8	
8	76943	1	Flap, rubber	
9	76945	2	Latch, wing knob	
10	76946	2	Cam, latch 8mm offset	
11	76925	1	Lid, control panel cover	
12	76944	2	Hinge, butt - 6mm mount	
13	76930	1	Gasket, control panel lid	
14	10000007540	1	Drip edge	

CONTROL PANEL ASSEMBLY (1 OF 3)

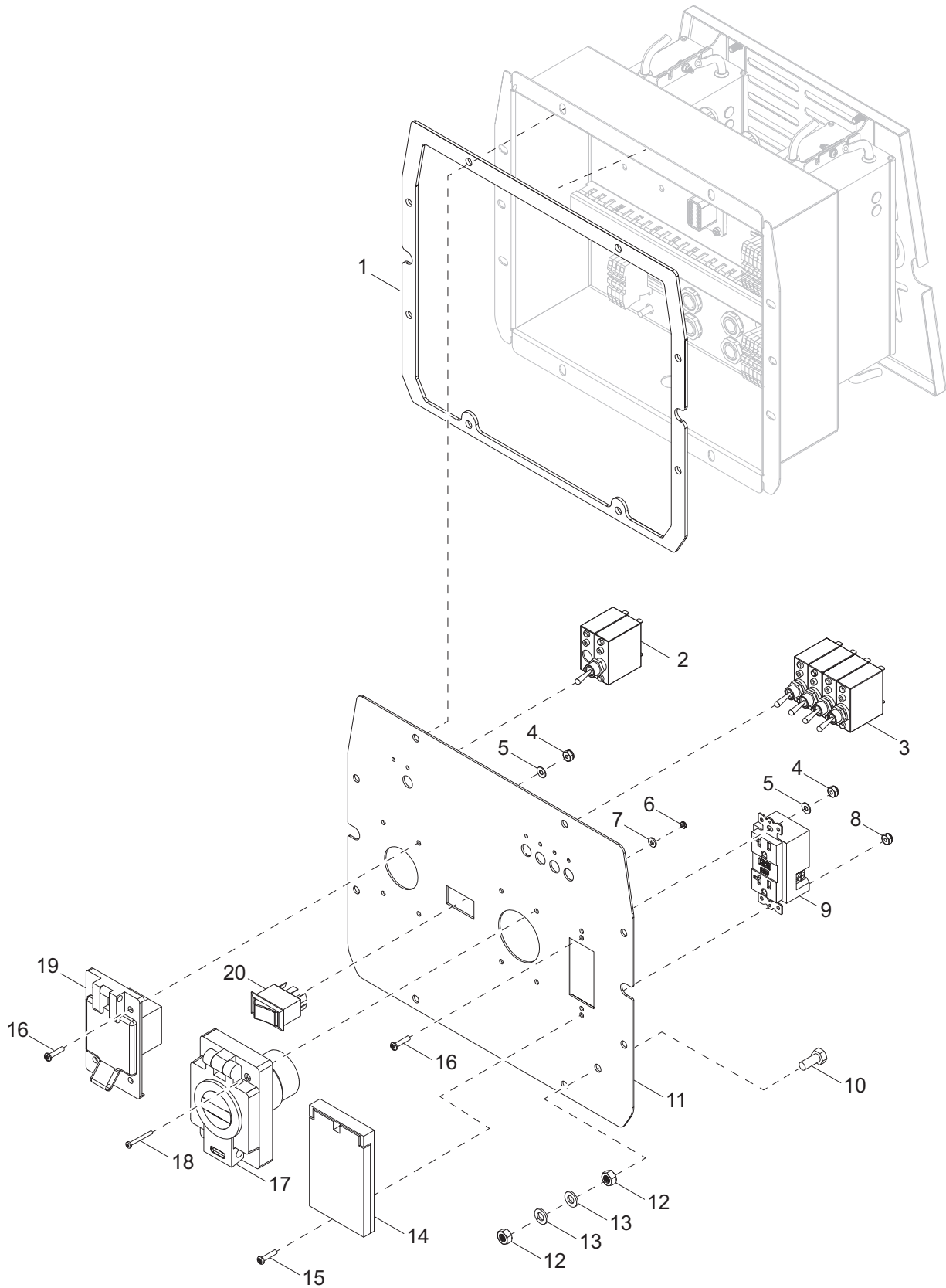

02652

CONTROL PANEL ASSEMBLY (1 OF 3)

Item	Part No.	Qty	Description	Notes
1	76929	1	Gasket, control panel	
2	75015	1	Breaker, 2-pole, 15A & 20A - dual linked	
3	75016	4	Switch, lights, 5A	
4	60270	6	Nut, 8-32 nylock	
5	60269	6	Washer, #8 flat .433/.036	
6	60728	4	Nut, 6-32 nylock, G5	
7	60289	4	Washer, #6 flat	
8	60758	2	Nut, 4-40 nylock, G2	
9	14130	1	Receptacle, 120V/20A GFI	
10	69985	1	Screw, M8-1.25 x 25 standard hex - brass	
11	56510	1	Plate, control panel	
12	69986	2	Nut, M8-1.25 - brass	
13	69987	2	Washer, M8 flat - brass	
14	37017	1	Cover, receptacle - weather proof	
15	60757	2	Screw, 4-40 x .750 pan Phillips, G2	
16	60694	6	Screw, 8-32 x .750 pan Phillips - SS	
17	75014	1	Receptacle, 120V/20A inlet w/cover	
18	69988	4	Screw, 6-32 x 1.25 pan Phillips - SS	
19	65385	1	Receptacle, 120V/15A inlet w/cover	
20	68530	1	Switch, rocker DPDT - on/on	
	55090	1	Assembly, control box with drivers	

CONTROL PANEL ASSEMBLY (2 OF 3)

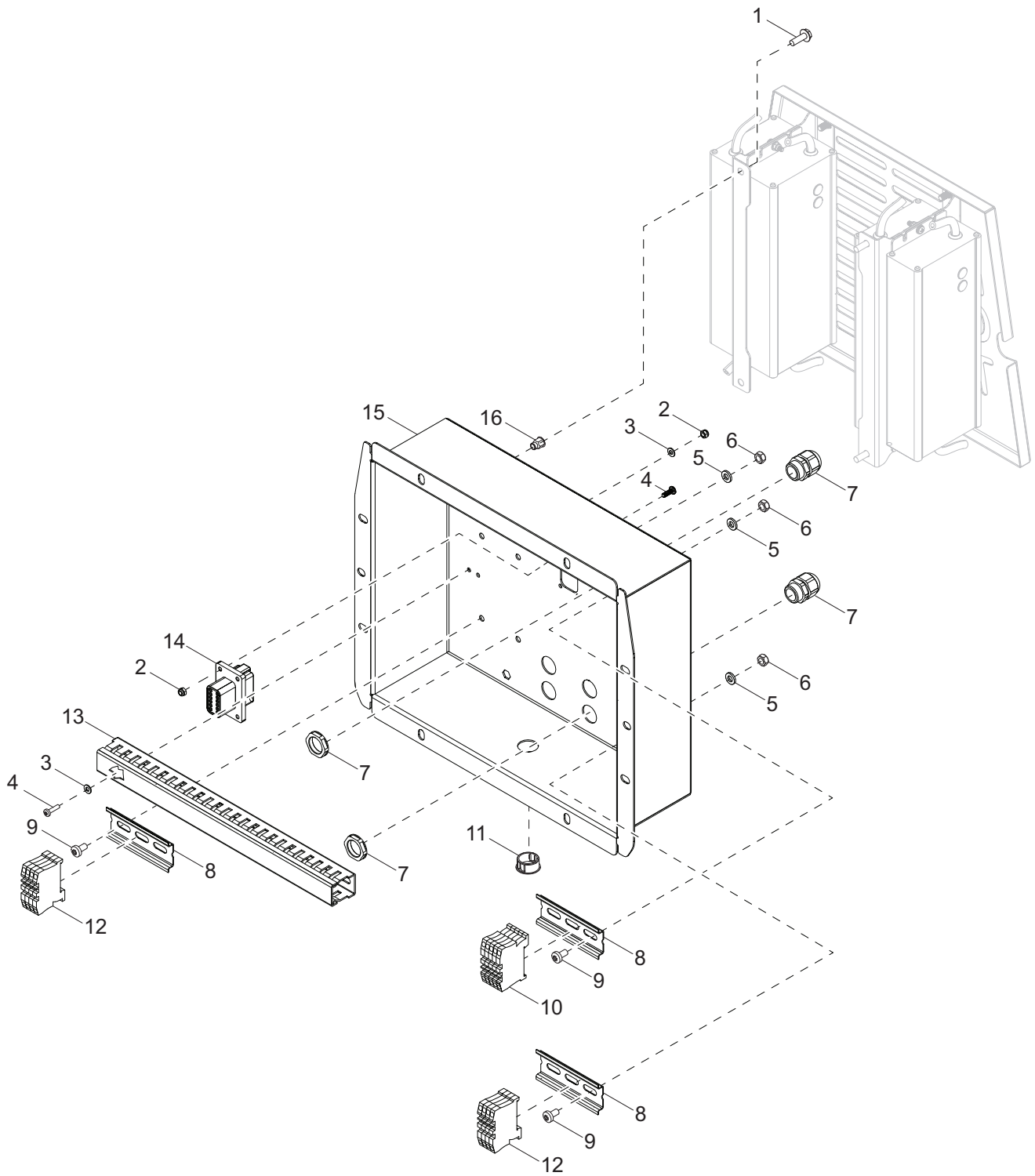

02240

CONTROL PANEL ASSEMBLY (2 OF 3)

Item	Part No.	Qty	Description	Notes
1	60087	4	Screw, M6-1.00 x 16 serrated flange hex, G8.8	
2	60051	2	Nut, M4-.700 nylock, G8.8	
3	60084	4	Washer, M4 flat	
4	60091	6	Screw, M4-.700 x 12 pan Phillips, G4.8	
5	69983	6	Washer, M6 flat	
6	60047	6	Nut, M6-1.00 nylock, G8.8	
7	56503	8	Connector, cable compression - nylon	
8	56506	3	Rail, terminal mount	
9	63288	6	Screw, M6-1.00 x 12 pan Phillips, G8.8	
10	56508	5	Terminal block, 2 conductor 12AWG - green	
11	56609	1	Plug, knockout 20mm	
12	56507	8	Terminal block, 2 conductor 12AWg - gray	
13	56505	1	Duct, wire routing	
14	66695	1	Connector, Deutsch 12 pos recept/pin - flange	
15	56504	1	Housing, electrical component	
16	69991	4	Insert, M6-1.00 hex .50-3.00mm grip	

CONTROL PANEL ASSEMBLY (3 OF 3)

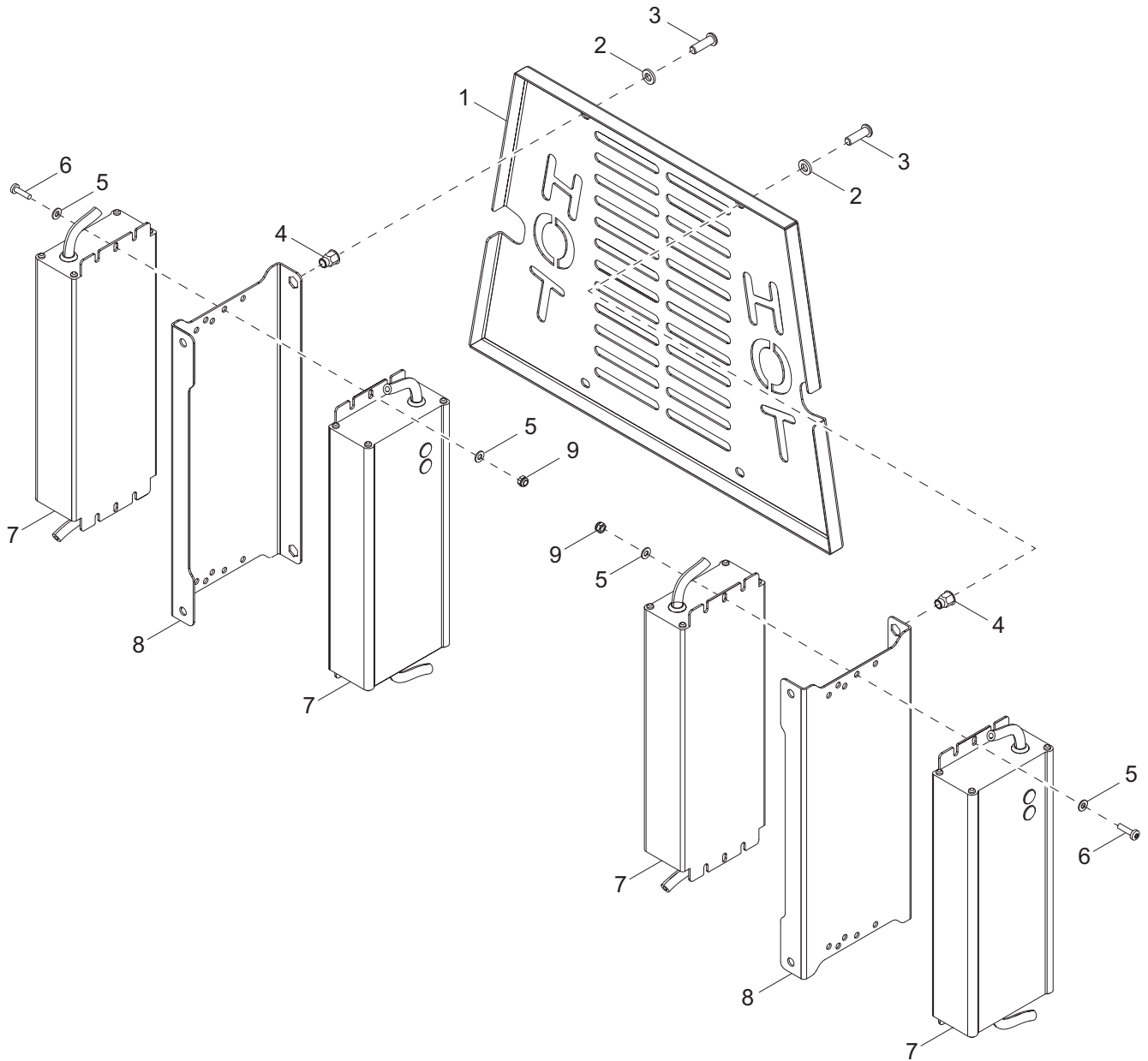

02241

CONTROL PANEL ASSEMBLY (3 OF 3)

Item	Part No.	Qty	Description	Notes
1	72180	1	Cover, LED driver	
2	69983	4	Washer, M6 flat	
3	69982	4	Screw, M6-1.00 x 16 button hex	
4	69991	4	Insert, M6-1.00 hex .50-3.00mm grip	
5	60084	8	Washer, M4 flat	
6	53280	4	Screw, M4-700 x 16 pan Phillips	
7	72178	4	Driver, LED 30V, 10.7A-CC 320W	
8	72179	2	Bracket, driver mount	
9	60051	4	Nut, M4-.700 nylock, G8.8	

TRAILER ASSEMBLY

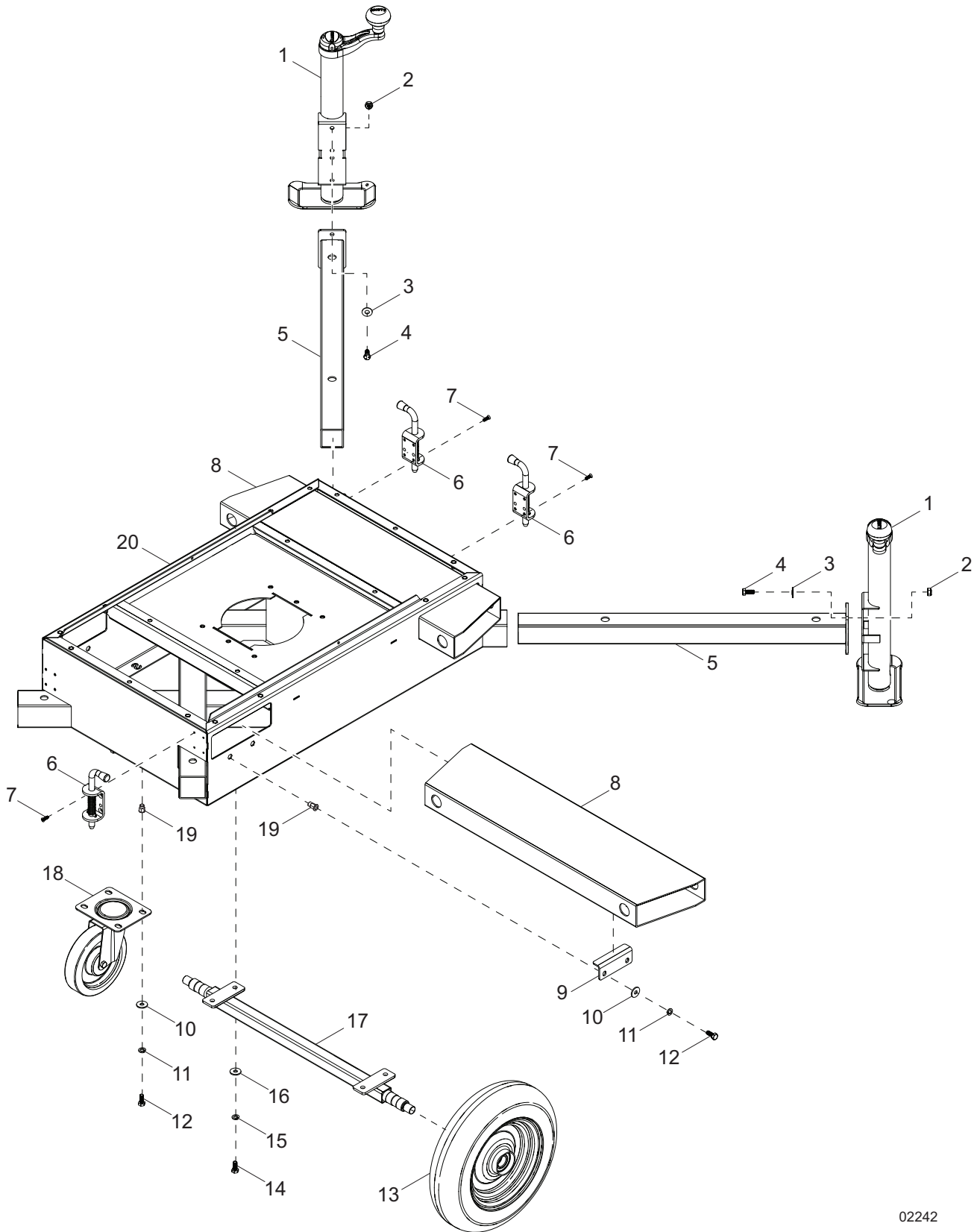

02242

TRAILER ASSEMBLY

Item	Part No.	Qty	Description	Notes
1	54788	4	Jack, top wind, 1200lb - large foot	
2	62079	8	Nut, .312 nylock - jam	
3	60119	8	Washer, .312 flat .875/.070	
4	60168	8	Screw, .312-18 x .750 standard hex, G5	
5	56519	4	Weldment, outrigger/jack mount	
6	56516	4	Spring pin, M5 mount	
7	69977	16	Screw, M5-.80 x 16 flat Phillips	
8	56517	2	Tube guide, forklift	
9	56518	4	Bracket, tube guide - forklift	
10	69981	12	Washer, M8 flat	
11	60029	12	Washer, M8 split lock	
12	61082	12	Screw, M8-1.25 x 20 standard hex	
13	56514	2	Wheel, 3.50 x 8.00 rubber - full	
14	53334	4	Screw, M6-1.00 x 20 hex, G8.8	
15	38522	4	Washer, M6-.250 split lock	
16	69975	4	Washer, M6 flat	
17	56513	1	Weldment, axle and hub	
18	56515	1	Caster w/lock, 6.00	
19	69992	12	Insert, M8-1.25 hex, .50 -3.50mm grip	
20	56512	1	Weldment, frame base	

RECOMMENDED SPARE PARTS

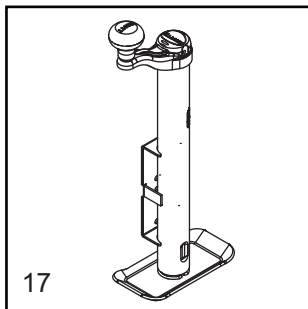
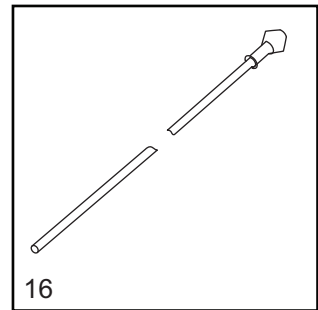
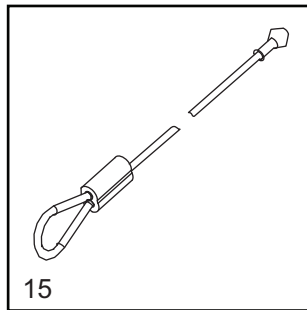
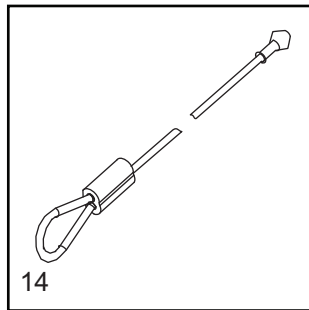
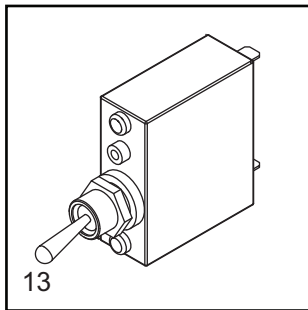
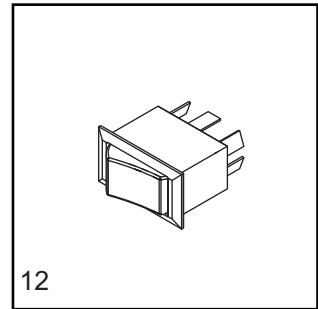
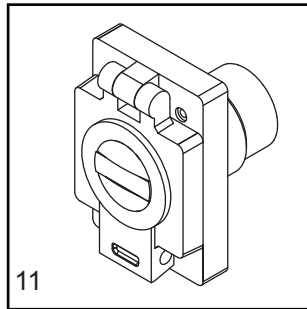
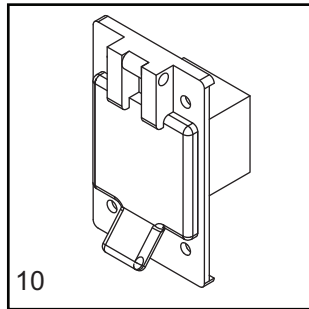
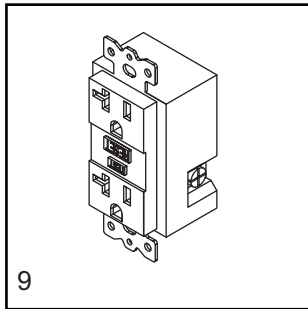
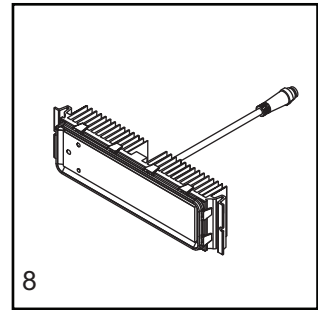
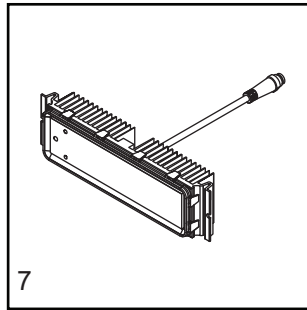
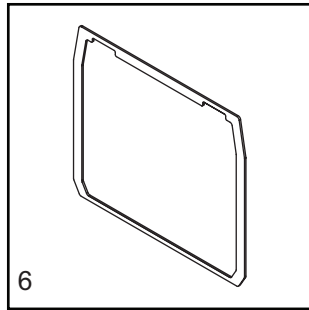
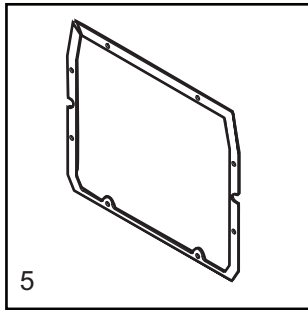
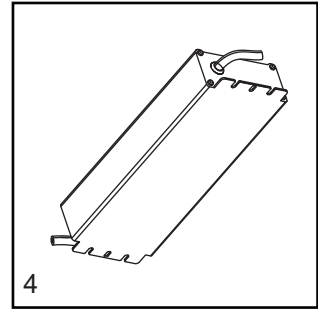
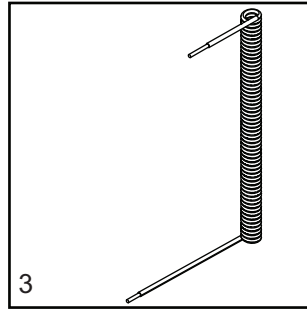
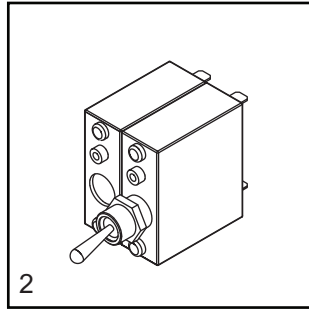
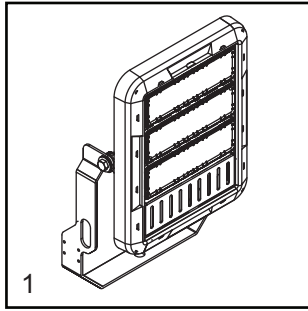

ELECTRICAL

1. Assembly, LED I3 module w/blank.....	10000032932
2. Breaker, 2-pole, 15A and 20A dual.....	75015
3. Coil cord	10000026846
4. Driver, LED 30V, 10.7A-CC 320W.....	72178
5. Gasket, control panel	76929
6. Gasket, control panel lid.....	76930
7. Module, 60°28 LED 24-27VDC - 60W	10000019170
8. Module, 40°28 LED 24-27VDC - 60W	10000019160
9. Receptacle, 120V/20A GFI.....	14130
10. Receptacle, 120V/15A inlet w/cover.....	65385
11. Receptacle, 120V/20A inlet w/cover	75014
12. Switch, rocker DPDT - on/on.....	68530
13. Switch, lights 5A	75016

MAST

14. Cable, .5 x 88.6 long (top cable)	56545
15. Cable, .5 x 44.9 long (bottom cable)	54546
16. Cable, .5 x 45.7 long (middle cable).....	54547

TRAILER

17. Jack, top wind	54788
--------------------------	-------

This Page Intentionally Left Blank

Part No. 54801 Rev. D 09/11/2018

©2018 Generac Mobile Products, LLC
All rights reserved.

Specifications are subject to change without notice.
No reproduction allowed in any form without prior written consent
from Generac Mobile Products, LLC.

GENERAC | **MOBILE**

Generac Mobile Products, LLC
215 Power Drive, Berlin, WI 54923
GeneracMobileProducts.com | 800-926-9768 | 920-361-4442