



Image used for illustration purposes only



*Assembled in the USA using domestic and foreign parts

Codes and Standards

Generac Mobile products are designed to the following standards:



TIER 4 FINAL EMISSIONS



NATM



TRANSPORT CANADA (OPTIONAL)



CSA (OPTIONAL)

Power When and Where You Need It

Generac Mobile indirect heaters are designed and engineered to provide heat, in the most extreme environments. Heaters are configured to meet customer needs.

Generac Mobile heaters are manufactured to deliver reliable heat, when and where you need it.

STANDARD FEATURES

ENGINE SYSTEM

- Isuzu® 3CE1-UGZG1 3 Cylinder Diesel
- Naturally Aspirated
- EPA Tier 4 Final
- 97.6 in³ (1.6 L) Displacement
- Power @ 1,800 rpm: 21.1 hp (15.7 kW)
- Air Filter: Dry Type Cartridge
- Engine Coolant Heater 110V

COOLING SYSTEM

- Liquid Cooled
- Coolant Capacity: 6.0 qt (5.7 L)
- Capable Of Operating at -40 to 100 °F (-40 to 37.8 °C) Ambient – Not Considering Derate Factors

LUBRICATION SYSTEM

- Oil Capacity: 7.1 qt (6.7 L)
- 250 hr Service Interval**

FUEL SYSTEM

- Fuel Tank Capacity - US gal (L):
 - Total: 189 (715.4)
 - Usable: 171 (647.3)
- Fuel Consumption Rate (engine + burner): 6.25 gph (23.7 Lph)
- Minimum Run Time: 27.3 hr
- Fuel Filter: Two Spin-on; One For Engine and One For Burner
- See Specifications Section for Details

HEATER SYSTEM

- Burner: Riello 40F15 Single Stage Diesel Fuel
 - Firing Rate: 2.55-5.75 gph (9.65-21.77 Lph)
 - Heat Produced: 357,000-805,000 BTU/hr
 - Temperature Range: 120 to 180 °F (48.9 to 82.2 °C)
- Fan:
 - Air Ducts: Two 12 in (30.5 cm) Diameter
 - Efficiency: 85%
 - Fan Motor: TECO 5 hp (3.73 kW) @ 3,600 rpm
 - Fan Wheel: BC-SW 135 CL II
 - Fan Performance:
 - 3,900 ft³/m (110.4 m³/min)
 - 5 in WG (1.24 kPa) Static Pressure
- Heat Exchanger:
 - Large Heating Surface (158 ft²)
 - Dual Air Pass Design
 - Maintenance and Filter Free
 - Fully Welded Stainless Steel Construction

ALTERNATOR

- Marathon® 282CSL1504
- 13.5 kW 208V 3-Phase
- 20 Amp 110V External Outlet

SAFETY

- Burner Fire Eye - Shuts Off Fuel Pump if No Flame Is Present In Burner
- Air Differential Switch - Shuts Off Burner if No Air Flow Is Present
- High Limit Switch - Shuts Off Burner if Air Temperature Exceeds 200 °F (90 °C)

CONTROLS

- LOFA® MC704 Engine Control Panel
- Pushbutton Start Fan Control
- Programmable Thermostat
- Wiring Harness With Circuit Breakers: 20-amp Outlet Breaker, 20-amp Burner Breaker

BATTERY

- One GRP24 12V, 720 CCA, Wet Cell Battery

ENCLOSURE

- All Steel Construction
- UV and Fade Resistant, High Temperature Cured, White Powder Paint
- Replaceable Sectional Roof and Side Panels
- Fully Lockable Enclosure
- Rear Internal Storage For Air Ducts
- Operating and Safety Decals
- Document Holder With Owner's Manual and Wiring Diagrams

TRAILER

- 2-5/16 in Ball Hitch - Adjustable Height
- Tongue Jack and Transportation Tie Downs
- Electric Brakes
- Forklift Tubes: Integrated Forklift Tubes Extend to Fender to Prevent Forklift Damage
- DOT and TC Approved Lights, Tail, Brakes, and Directionals
- One 6,000 lb (2,721.6 kg) Axle with 235 80/R16 10 ply Load Range E Tires

OPTIONS*

- CSA B138 Double Wall Tank
 - ULT-S601 (Containment Standard)
 - UN31A (Rollover Leak Requirement)
- Spare Tire And Carrier
- Rear Stabilizer Jacks
- 1 x 20 in (50.8 cm) Duct Outlet
- 2-5/16 in. BULLDOG® Hitch – Adjustable Height
- 3 in. Pintle Ring – Adjustable
- Fuel Filter Heaters
- Fire Extinguisher
- 60/40 Coolant



* Additional options may be available. Contact a Sales Representative or the factory for current options.

** For maximum service interval, replace oil filter after 50-hr break-in period. For oil filter model number, see parts manual.

SPECIFICATIONS*

DIMENSIONS

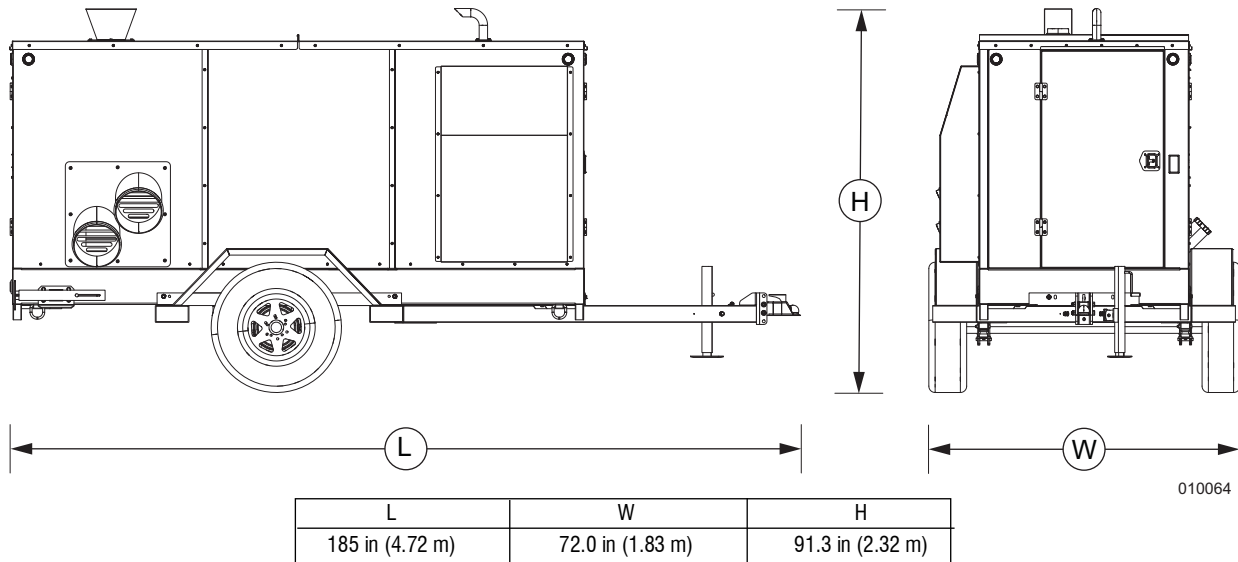

FUEL CAPACITIES

	Non-CSA (Standard)	CSA (Optional)
Total Fuel Capacity (US Gal)	189	160
Usable Fuel Capacity (US Gal)	171	145
Fuel Consumption Rate (US Gal/hr)	6.25	6.25
Minimum Runtime (hr)	27.3	23.2
Tank Type	Single Wall	Double Wall

WEIGHT

- Dry: 4,900 lb (2,223 kg)
- Operating: 6,080 lb (2,758 kg)

WARRANTY

- 1 year, unlimited hours

YOUR FACTORY RECOGNIZED GENERAC MOBILE DEALER

Specification characteristics may change without notice. Dimensions and weights are for preliminary purposes only. Please consult a Generac Mobile Authorized Service Dealer for detailed installation drawings.