

MD750 | 33.9L | 750 kW

INDUSTRIAL DIESEL GENERATOR SET

EPA Certified Stationary Emergency

STANDBY POWER RATING

750 kW, 938 kVA, 60 Hz

PRIME POWER RATING*

675 kW, 844 kVA, 60 Hz

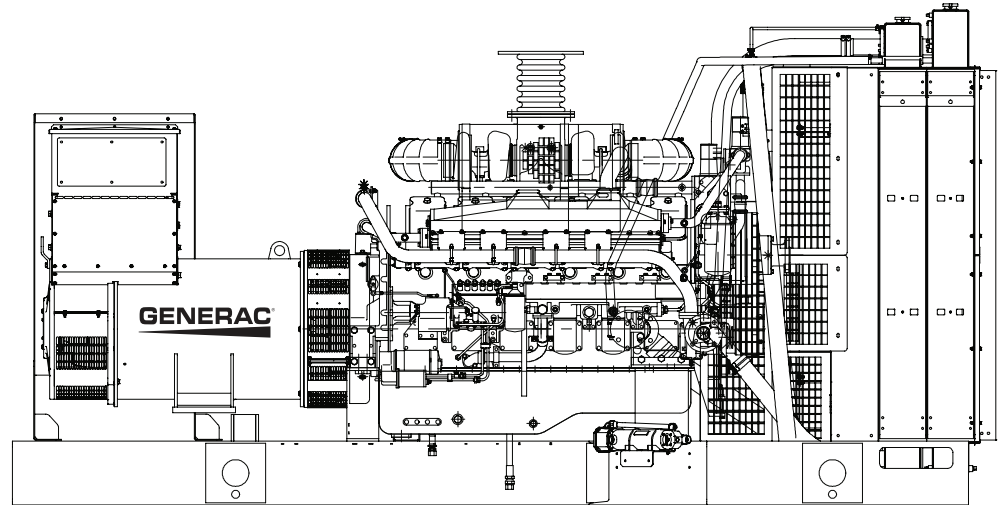

*Built in the USA using domestic and foreign parts

*EPA Certified Prime ratings are not available in the U.S. or its Territories.

Image used for illustration purposes only

**Certain options or customization may not hold certification valid.

CODES AND STANDARDS

Generac products are designed to the following standards:

 UL2200, UL508, UL142, UL498

 NFPA70, 99, 110, 37

 NEC700, 701, 702, 708

 ISO9001, 8528, 3046, 7637,
Pluses #2b, 4

 NEMA ICS10, MG1, 250, ICS6, AB1

 **ANSI**
American National Standards Institute

ANSI C62.41

POWERING AHEAD

For over 50 years, Generac has led the industry with innovative design and superior manufacturing.

Generac ensures superior quality by designing and manufacturing most of its generator components, including alternators, enclosures and base tanks, control systems and communications software.

Generac's gensets utilize a wide variety of options, configurations and arrangements, allowing us to meet the standby power needs of practically every application.

Generac searched globally to ensure the most reliable engines power our generators. We choose only engines that have already been proven in heavy-duty industrial application under adverse conditions.

Generac is committed to ensuring our customers' service support continues after their generator purchase.

STANDARD FEATURES

ENGINE SYSTEM

General

- Oil Drain Extension
- Air Cleaner
- Fan Guard
- Stainless Steel flexible exhaust connection
- Hospital Grade Silencer
- Factory Filled Oil & Coolant
- Radiator Duct Adapter (open set only)

Fuel System

- Flexible fuel lines
- Primary and secondary fuel filters

Cooling System

- Closed Coolant Recovery System
- UV/Ozone resistant hoses
- Factory-Installed Radiator
- 50/50 Ethylene glycol antifreeze
- Coolant Heater with Isolation Valves

Engine Electrical System

- Battery charging alternator
- Battery cables
- Battery tray
- Solenoid activated starter motor
- Rubber-booted engine electrical connections

ALTERNATOR SYSTEM

- Class H insulation material
- 2/3 Pitch
- Skewed Stator
- Permanent Magnet Excitation
- Sealed Bearings
- Amortisseur winding
- Full load capacity alternator

GENERATOR SET

- Separation of circuits—high/low voltage
- Separation of circuits—multiple breakers
- Standard Factory Testing
- 2 Year Limited Warranty (Standby rated Units)
- 1 Year Limited Warranty (Prime rated units)

ENCLOSURE (IF SELECTED)

- Rust-proof fasteners with nylon washers to protect finish
- High performance sound-absorbing material (L1 & L2)
- Gasketed doors
- Stamped air-intake louvers
- Vertical Discharge Hoods
- Polished steel lift on door hinges
- Polished steel lockable handles

TANKS (IF SELECTED)

- UL 142
- Double wall
- Vents
- Sloped top
- Sloped bottom
- Factory pressure tested (2 psi)
- Rupture basin alarm
- Fuel level
- Check valve in supply and return lines
- Stainless hardware

CONTROL SYSTEM

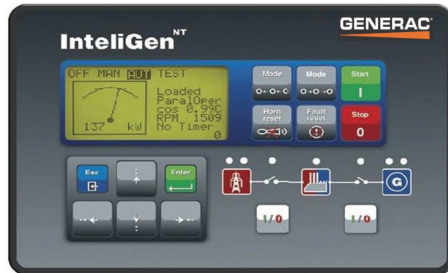

Control Panel

- IntelliGen NT Display
- Programmable Crank Limiter
- 7-Day Programmable Exerciser
- Special Applications Programmable PLC
- RS-232/485
- Full System Status
- Utility Monitoring
- Low Fuel Pressure Indication
- 2-Wire Start Compatible
- Power Output (kW)
- Power Factor

- kW Hours, Total
- Real/Reactive/Apparent Power
- All Phase AC Voltage
- All Phase Currents
- Oil Pressure
- Coolant Temperature
- Coolant Level
- Engine Speed
- Battery Voltage
- Frequency
- Date/Time Fault History (Event Log)
- Isochronous Governor Control
- Waterproof/sealed Connectors
- Audible Alarms and Shutdowns
- Auto/O/Manual Switch
- E-Stop (Red Mushroom-Type)
- NFPA110 Level I and II (Programmable)
- Customizable Alarms, Warnings, and Events
- Modbus protocol
- Predictive Maintenance algorithm
- Sealed Boards
- Password parameter adjustment protection

- Single point ground
- 15 channel data logging
- 20 msec high speed data logging
- Alarm information automatically comes up on the display

Alarms

- Oil Pressure (Pre-programmable Low Pressure Shutdown)
- Coolant Temperature (Pre-programmed High Temp Shutdown)
- Coolant Level (Pre-programmed Low Level Shutdown)
- Low Fuel Pressure Alarm
- Engine Speed (Pre-programmed Over speed Shutdown)
- Battery Voltage Warning
- Alarms & warnings time and date stamped
- Alarms & warnings for transient and steady state conditions
- Snap shots of key operation parameters during alarms & warnings
- Alarms and warnings spelled out (no alarm codes)

PARALLELING CONTROLS

- Auto-synchronization process
- Isochronous load sharing
- Reverse power protection
- Maximum power protection
- Electrically operated, mechanically held paralleling switch
- Sync check system
- Independent on-board paralleling

- Optional programmable logic full auto back-up control (pls)
- Shunt Trip and Auxiliary Contact

CONFIGURABLE OPTIONS

ENGINE SYSTEM

General

- 50° C Ambient Cooling System
- Heavy Duty Air Cleaner
- Critical & Hospital Grade Silencers
- CCV (Closed Crankcase Ventilation)

Fuel Electrical System

- 10A & 20A UL battery charger
- Battery Warmer

ALTERNATOR SYSTEM

- Alternator Upsizing
- Anti-Condensation Heater

CIRCUIT BREAKER OPTIONS

- Main Line Circuit Breaker
- 2nd Main Line Circuit Breaker
- Shunt Trip and Auxiliary Contact
- Electronic Trip Breaker

GENERATOR SET

- Intelimonitor Communications Software (English Only)
- 8 Load Position Load Center
- AC Electrical Lighting Package (ELP)
- 5 Year Warranty
- 5 Year Extended Warranty
- Spring Isolators (Standard/Seismic)

ENCLOSURE

- Weather Protected Enclosure
- Level 1 Sound Attenuation
- Level 2 Sound Attenuation
- Steel Enclosure
- Aluminum Enclosure
- 150/180 MPH Wind Rating
- Louvers with Gravity Dampers
- Enclosure Heaters

TANKS (Size on last page)

- Electrical Fuel Level
- Mechanical Fuel Level
- 12 Hour Run Time
- 24 Hour Run Time
- Fuel Line Kits
- Fuel Water Separator

CONTROL SYSTEM

- NFPA 110 Compliant
- Remote Relay Board (8 or 16)
- Oil Temperature Sender with Indication Alarm
- Remote E-Stop (Break Glass-Type, Surface Mount)
- Remote E-Stop (Red Mushroom-Type, Surface Mount)
- Remote E-Stop (Red Mushroom-Type, Flush Mount)
- Remote Communication - Bridge
- Remote Communication - Ethernet
- 10A Run Relay, 12 outputs
- Ground Fault Indication and Protection Functions

ENGINEERED OPTIONS

ENGINE SYSTEM

- Fluid containment Pans/not plural
- Oil Heater
- Stainless Steel Hardware

ALTERNATOR SYSTEM

- 3rd Breaker Systems
- Unit Mounted Load Banks
- Medium Voltage Alternators

CONTROL SYSTEM

- Spare inputs (x4) / outputs (x4)
- Battery Disconnect Switch

GENERATOR SET

- Special Testing
- 12 VDC Enclosure Lighting Kit
- 24 VDC/120 VAC Enclosure Lighting Kit

ENCLOSURE

- Motorized Dampers
- Intrusion Alert Door Switch

TANKS

- Overfill Protection Valve
- UL2085 Tank
- ULC S-601 Tank
- Stainless Steel Tank
- Special Fuel Tanks (MIDEQ and FL DEP/DERM, etc.)
- Vent Extensions
- Transfer Pumps and Controllers
- Fuel Tank Heaters

RATING DEFINITIONS

Standby - Applicable for a varying emergency load for the duration of a utility power outage with no overload capability.

Prime - Applicable for supplying power to a varying load in lieu of utility for an unlimited amount of running time. A 10% overload capacity is available for 1 out of every 12 hours. The Prime Power option is only available on International applications. Power ratings in accordance with ISO 8528-1, Second Edition

APPLICATION AND ENGINEERING DATA

ENGINE SPECIFICATIONS

General

Make	Mitsubishi
EPA Emissions Compliance	Tier 2
EPA Emissions Reference	See Emissions Data Sheet
Cylinder #	12
Type	4 Cycle
Displacement - L (cu In)	33.9 (2071)
Bore - mm (in)	150 (5.91)
Stroke - mm (in)	160 (6.30)
Compression Ratio	15.3:1
Intake Air Method	Turbocharged/Intercooled
Cylinder Head Type	4 - Valve
Piston Type	Aluminium
Crankshaft Type	Drop Forged Steel

Engine Governing

Governor	Proact2 Isochronous
Frequency Regulation (Steady State)	+/- 0.25%

Lubrication System

Oil Pump Type	Gear
Oil Filter Type	Cartridge
Crankcase Capacity - L (qts)	100 (106)

Cooling System

Cooling System Type	Unit Mounted Radiator
Water Pump	Centrifugal
Fan Type	Pusher
Fan Speed (rpm)	1085
Fan Diameter mm (in)	1625 (64)
JW Coolant Heater Standard Wattage	6000
After Coolant Heater Standard Wattage	2500
Coolant Heater Standard Voltage	240-1

Fuel System

Fuel Type	Ultra Low Sulfur Diesel #2
Fuel Specifications	Diesel #2
Fuel Filtering (microns)	10 (final filters)
Fuel Injection	Mechanical
Fuel Pump Type	Engine Driven Gear
Injector Type	Bosch PType x 2
Engine Type	S12A2-Y2PTAW-2
Fuel Supply Line mm (in)	19.0 (3/4" NPT)
Fuel Return Line mm (in)	19.0 (3/4" NPT)

Engine Electrical System

System Voltage	24 VDC
Battery Charging Alternator	Std
Battery Size	See Battery Index 0161970SBY
Battery Group	8D
Battery Voltage	(2) - 12 VDC
Ground Polarity	Negative

ALTERNATOR SPECIFICATIONS

Standard Model	750kW, 125°C, NEMA H
Poles	4
Field Type	Rotating
Insulation Class - Rotor	H
Insulation Class - Stator	H
Total Harmonic Distortion	<5%
Telephone Interference Factor (TIF)	<50

Standard Excitation	Permanent Magnet
Bearings	Single Sealed Cartridge
Coupling	Direct, Flexible Disc
Load Capacity - Standby	100%
Prototype Short Circuit Test	Yes
Voltage Regulator Type	Analog
Regulation Accuracy (Steady State)	±0.5%

MD750 | 33.9L | 750 kW

INDUSTRIAL DIESEL GENERATOR SET

EPA Certified Stationary Emergency

OPERATING DATA

POWER RATINGS

		Standby
Three-Phase 120/208 VAC @0.8pf	750 kW	Amps: 2602
Three-Phase 120/240 VAC @0.8pf	750 kW	Amps: 2255
Three-Phase 277/480 VAC @0.8pf	750 kW	Amps: 1128
Three-Phase 347/600 VAC @0.8pf	750 kW	Amps: 902

FUEL CONSUMPTION RATES*

Fuel Pump Lift - ft (m)	Diesel - gph (lph)	
	Percent Load	gph (lph)
3 (1)	25%	19.3 (73.1)
	50%	32.2 (121.9)
Total Fuel Pump Flow (Combustion + Return) - gph (lph)	75%	46.8 (177.1)
148 (560.2)	100%	65.2 (246.8)

* Fuel supply installation must accommodate fuel consumption rates at 100% load.

COOLING

Cooling Rating - Jacket Water			Cooling Rating - Aftercooler		
		Standby			Standby
Coolant Flow per Minute	gpm	291	Coolant Flow per Minute	gpm	124
Coolant System Capacity	gal	61	Coolant System Capacity	gal	43
Heat Rejection to Coolant	BTU/min	18,388	Heat Rejection to Coolant	Btu/min	14,450
Inlet Air - 40°C Cooling Package	cfm	35,900			
Inlet Air - 50°C Cooling Package	cfm	40,100			
Maximum Additional Radiator Backpressure	in H ₂ O	0.5			

COMBUSTION AIR REQUIREMENT

	Standby
Flow at Rated Power cfm (m ³ /min)	3107 (88)

ENGINE

		Standby
Rated Engine Speed	rpm	1800
Horsepower at Rated kW**	hp	1207
Piston Speed	ft/min	1890
BMEP	psi	240

** Refer to "Emissions Data Sheet" for maximum bHP for EPA and SCAQMD permitting purposes.

EXHAUST

		Standby
Exhaust Flow (Rated Output)	cfm (m ³ /min)	8192 (232)
Max. Backpressure (Post Turbo)	inHg (Kpa)	1.7 (5.9)
Exhaust Temp (Rated Output - post silencer)	°F (°C)	908 (487)
Exhaust Outlet Size (Open Set)	mm (in)	JIS200A

Deration – Operational characteristics consider maximum ambient conditions. Derate factors may apply under atypical site conditions. Please consult a Generac Power Systems Industrial Dealer for additional details. All performance ratings in accordance with ISO3046, BS5514, ISO8528 and DIN6271 standards.

DIMENSIONS AND WEIGHTS*

OPEN SKID

RUN TIME HOURS	USABLE CAPACITY GAL (L)	L x W x H in (mm)	WT lbs (kg) - Tank & Open Set
NO TANK	-	180 (4565) x 83 (2098) x 95 (2398)	22496 (10204)
12	800 (3029)	201 (5105) x 103 (2608) x 119 (3002)	26446 (11996)
24	1600 (6058)	201 (5105) x 103 (2308) x 132 (3332)	27822 (12620)

WEATHER RESISTANT

RUN TIME HOURS	USABLE CAPACITY GAL (L)	L x W x H in (mm)	WT lbs (kg) - Tank & Open Set
NO TANK	-	235 (5969) x 98 (2489) x 171 (4326)	28049 (12723)
12	800 (3029)	235 (5969) x 104 (2659) x 175 (4442)	30078 (13642)
24	1600 (6058)	235 (5969) x 104 (2659) x 188 (4772)	31454 (14268)

LEVEL 1 SOUND ATTENUATED

RUN TIME HOURS	USABLE CAPACITY GAL (L)	L x W x H in (mm)	WT lbs (kg) - Tank & Open Set
NO TANK	-	289 (7341) x 100 (2523) x 170 (4299)	31454 (14268)
12	800 (3029)	289 (7341) x 106 (2693) x 170 (4298)	33067 (14999)
24	1600 (6058)	289 (7341) x 106 (2693) x 179 (4526)	34217 (15521)

LEVEL 2 SOUND ATTENUATED

RUN TIME HOURS	USABLE CAPACITY GAL (L)	L x W x H in (mm)	WT lbs (kg) - Tank & Open Set
NO TANK	-	340 (8633) x 150 (3810) x 170 (4299)	32633 (14802)
12	800 (3029)	340 (8633) x 150 (3810) x 170 (4298)	35388 (16052)
24	1600 (6058)	340 (8633) x 150 (3810) x 179 (4526)	36538 (16574)

*All measurements are approximate and for estimation purposes only. Sound dBA can be found on the sound data sheet. Enclosure Only weight is added to Tank & Open Set weight to determine total weight.

YOUR FACTORY RECOGNIZED GENERAC INDUSTRIAL DEALER

Specification characteristics may change without notice. Dimensions and weights are for preliminary purposes only. Please consult a Generac Power Systems Industrial Dealer for detailed installation drawings.